

# Circle Time

## Famous

# Artists

## Unit for Preschoolers

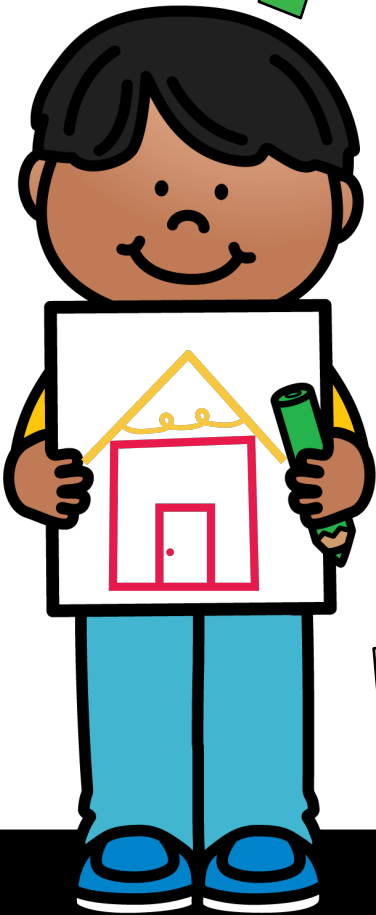

**P-A-I-N-T**  
To the tune of "Bingo"  
I am an artist  
Yes, I am.  
I make beautiful paintings.

**P-A-I-N-T**  
**P-A-I-N-T**  
**P-A-I-N-T**

I make beautiful paintings.



### Lines & Squares

**Day 4 Art Project**

**Step 1:** Gather the materials:  
• 9" x 10" canvas (1 per student - can also use poster board or white cardstock)  
• Kwik Sticks (or paint of choice)  
• tack; electrical tape

**Step 2:** Place electrical tape on canvas in horizontal and vertical lines. Allow students to attract where to place the lines.

**Step 3:** Model how to paint rectangles and squares. Remind students to leave some white space like Mondrian did.

**Step 4:** Provide time for students to create their own Piet Mondrian inspired artworks.

\*Encourage students to sign each piece like a true artist. Hang the completed pieces around the room in a gallery style format.

©Play to Learn Preschool



# Circle Time Lessons

## Unit overview

### Day 1 Introduction

Discuss how anyone can be an artist. Take a poll and play an art grid game.

### Day 2 Frida Kahlo

Read a biography, look at famous paintings, learn colors in Spanish and complete a concept sort. Create a colorful self-portrait.

### Day 3 Andy Warhol

Read a biography, look at famous artwork, recite a counting poem, and play a carpet game. Create a pop art masterpiece.

### Day 4 Piet Mondrian

Read a biography, look at famous pieces, sort items by straight lines, and sing a bingo song. Paint a lines & squares creation.

### Day 5 Wassily Kandinsky

Read a biography, look at famous paintings, practice identifying shapes using a song, and practice concept of word. Create a concentric circle painting.

# Circle Time Lessons

## Unit overview

### Day 6 Yoyoi Kusama

Read a biography, look at famous work, practice patterning, and recite a numbers poem. Create an art piece using polka dots.

**Yoyoi Kusama**  
Yaa-yoo Koo-saa-muh

Yoyoi Kusama views the world in a series of colorful dots. These dots form the foundation of her artwork.

**Objectives:**

- The students will notice and extend simple patterns.
- The students will play with words, sounds, and rhymes.
- The students will use fine motor skills to produce works of art.

**Activities:**

- Introduce Yoyoi Kusama by reading her biography and showing some of her famous paintings. (Link to the biography page.)
- Make an AB and AAB pattern with the art supply cards. Ask students what comes next in the pattern.
- Sing the "Ten Little Polka Dots" song. Print out the ten-frame and counters, then practice counting from 1-10 and 10-1.
- Follow the steps to create a Yoyoi Kusama inspired polka dot work of art.

**Literacy Extension:** Read "Elephant" by David Mackay.

**10 Little Polka Dots**  
Ten little polka dots  
One, two, three, four, five, six, seven, eight, nine, ten  
Ten little polka dots  
One, two, three, four, five, six, seven, eight, nine, ten

### Day 7 Vincent Van Gogh

Read a biography, look at famous paintings, label a picture, and recite a chip clip poem. Create a sunflower with a directed drawing.

**Vincent Van Gogh**  
Vin-vant Van Go

With exhibits and collections housed all over the world, Vincent Van Gogh is one of the most recognized artists of all time.

**Objectives:**

- The students will count sets to 5 and make combinations of items to create the set.
- The students will demonstrate an understanding of print concepts.
- The students will use fine motor skills to produce works of art.

**Activities:**

- Introduce Vincent Van Gogh by reading his biography and showing some of his famous paintings. (Link to the biography page.) Bring in real sunflowers for the students to explore, if possible.
- Recite the "5 Pretty Sunflowers" counting poem.
- Print out the different parts of a sunflower. Label the picture of the sunflower.

**Literacy Extension:** Read "Elephant" by David Mackay.

**5 Pretty Sunflowers**  
Five pretty sunflowers  
One, two, three, four, five  
Five pretty sunflowers  
One, two, three, four, five

### Day 8 Alma Thomas

Read a biography, look at famous paintings, play a colors movement game, and practice rhyming. Create a colorful mosaic.

**Alma Thomas**  
Ad-muh Taa-muh

Alma Thomas was an art teacher before becoming a full-time artist after retiring. She drew inspiration from the way light speckled through nature.

**Objectives:**

- The students will follow oral directions.
- The students will recognize rhyming words.
- The students will use fine motor skills to produce works of art.

**Activities:**

- Introduce Alma Thomas by reading her biography and showing some of her famous paintings. (Link to the biography page.)
- Place construction paper around the room at students' eye level (red, pink, yellow, green, blue, and purple). Assemble the color wheel, recite the poem "Colors" and spin the wheel. Students move to the colored paper based on the color spun. Repeat as desired for practice in recognizing colors and active listening skills.
- Pass out an equal pair cards to each student. Take turns saying words. If the pictures rhyme, the students say "Aw-yeah!". If the pictures do not rhyme, the students cross their arms.
- Follow the steps to create an Alma Thomas inspired color field abstract piece of art.

**Literacy Extension:** Read "Astrace with Color" by Jeanne Harvey.

**Colors**  
Colors, colors, colors  
Red, yellow, green, blue, and purple  
Colors, colors, colors  
Red, yellow, green, blue, and purple

### Day 9 Pablo Picasso

Read a biography, look at famous artwork, play a "letter P" carpet game, and recite a shape chant. Create a face collage art piece.

**Pablo Picasso**  
Paa-blow Puh-kaw-saw

Pablo Picasso is one of the most well-known artists of all time. Although his style changed throughout his career, his artwork is uniquely his own.

**Objectives:**

- The students will recognize and identify shapes.
- The students will begin to make letter-sound connections.
- The students will use fine motor skills to produce works of art.

**Activities:**

- Show the real life picture of the artwork. Discuss.
- Play the "Letter P" carpet game.
- Recite the "I Know My Shapes" ask-back chant using the picture cards. Point out the attributes of each shape. (I know my shapes, I know my shapes, I know my shapes, I know my shapes.)

**Literacy Extension:** Read "Astrace with Color" by Jeanne Harvey.

**I Know the Shapes**  
I know the shapes  
Oh, oh, oh, oh  
I know the shapes  
Oh, oh, oh, oh

### Day 10 Conclusion

Review what was learned during the unit. Practice emergent writing and read a chip clip poem.

**Conclusion**  
Unit Conclusion

Art does not have just one style and anyone can be an artist. All that is needed is a bit of creativity and imagination.

**Objectives:**

- The students will draw and imitate the act of writing.
- The students will count sets to 5 and make combinations of objects to create each set.

**Activities:**

- Ask the students which artist is their favorite. Students can draw a picture or teachers can transcribe their responses on the attached recording sheets.
- Recite the "5 Busy Artists" chip clip poem. Start by having the 5 artist pictures attached to a large piece of drawing paper or easel. Remove an artist after each verse.
- Teach the ASL signs for each color using the included posters.

**Literacy Extension:** Read "Luna Loves Art" by Joseph Coelho.

**5 Busy Artists**  
Five busy artists  
One, two, three, four, five  
Five busy artists  
One, two, three, four, five

**To Play the Game**  
Place the right number of cards for your students. Identify the words together. Emphasize that each starts with the letter P like Picasso's name. Hide the 1st number one of the pictures and recite the poem to find it. Children guess where the letter P is hiding by identifying the number on the items.

**Letter P**  
Choose a picture and make a word.

### Bonus File - Claude Monet

# Introduction

## Activating Background Knowledge

Day 1  
lesson  
plans

Anyone can be an artist! Art is any form of expression or imagination. Some artists are painters. Others create sculptures or write songs and movies. There is no right or wrong way to make art.

### Objectives:

- The students will answer questions.
- The students will notice and extend simple patterns.

### Activities:

1. Ask the students to define what art is to them. Have the students draw a picture of themselves making art. Discuss how anyone can be an artist.
2. Take a poll, "What is your favorite color?" Students can use post-it notes or name cards to respond on a pocket chart or bar graph.
3. Play the Art Grid Game.

Name \_\_\_\_\_

Art can look like many things.  
Draw a picture of yourself creating art.

My Favorite Color is...

red	yellow	blue
Mirabel	Camilo	Luisa
Pepa		Dolores
		Antonio
orange	green	purple
Bruno	Felix	Mariano
	Pico	Agustin
	Isabela	

### Extension Idea:

An art memory tray will work on concentration and memory skills. Put 4 – 6 small items on a tray. (crayon, paint brush, pencil, etc.) Have students look away and remove one item. Students guess which item is missing.

### To Play:

1. Copy the template page onto 5 different colors of paper.
2. Create a grid where each column has the same item, and each row is the same color. Use as many pictures as are appropriate for your students. Discuss the pattern and relationship of the cards.
3. Students close their eyes while the teacher removes 1 card.
4. Students use their knowledge of patterns to determine which card (color and picture) is missing.

Which one is missing?

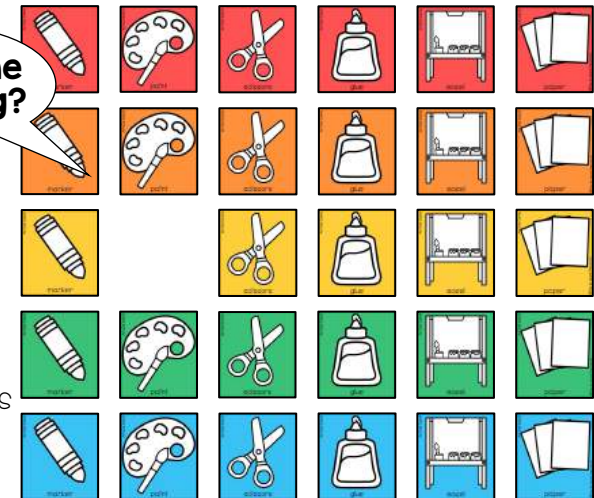

Name \_\_\_\_\_

Art can look like many things.

Draw a picture of yourself creating art.

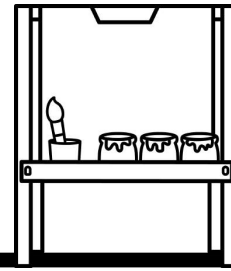



My Favorite Color is...



red

orange

yellow

green

blue

purple

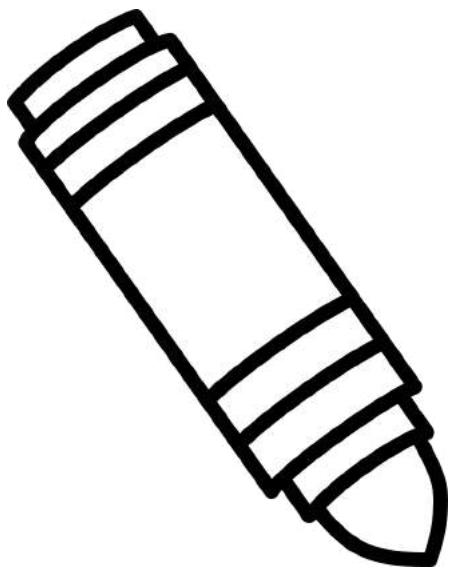

marker

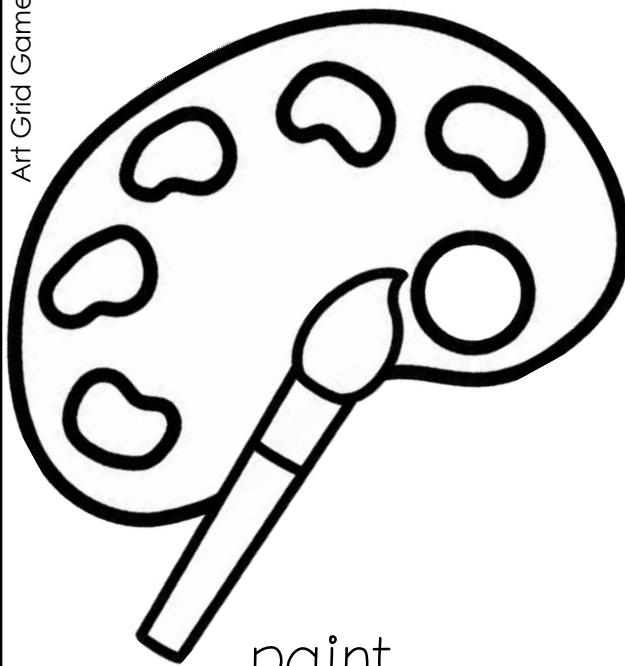

paint

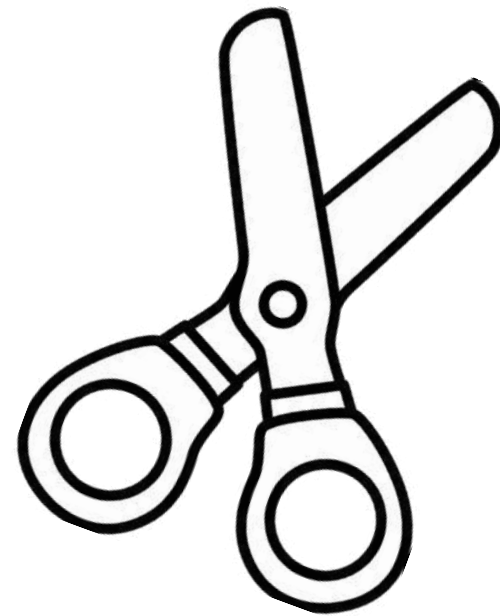

scissors



glue

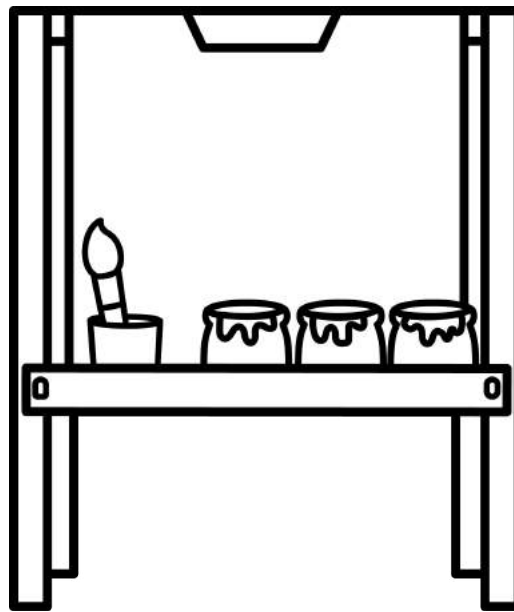

easel

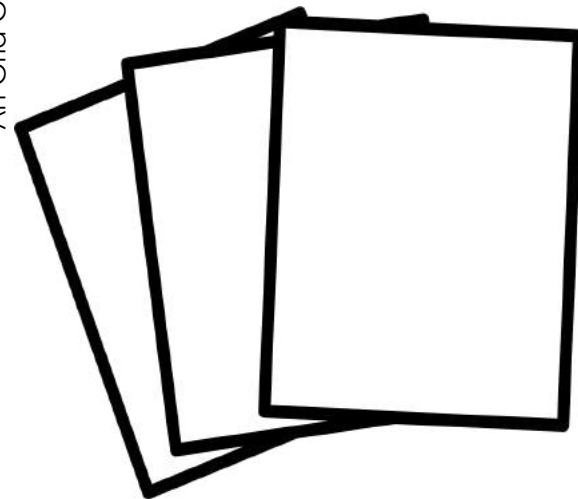

paper

# Frida Kahlo

Free-duh Kah-low

Day 2  
Lesson  
Plans

Frida Kahlo was born over 100 years ago in Mexico. She loved to paint and often painted colorful self-portraits.

## Objectives:

- The students will sort objects by property.
- The students will use fine motor skills to produce works of art.

## Activities:

1. Introduce Frida Kahlo by reading her biography and showing some of her famous paintings. (Links on the biography page.)
2. Show the paint brush pictures and try saying the colors in Frida's native language, Spanish. Say a color, then have the students search for something in the room that has that color.
3. Bring in a variety of objects to sort into two groups: things that are black & white and things that have a lot of colors. Picture cards are also included, if needed.
4. Follow the instruction page to create a Frida Kahlo inspired colorful self-portrait.

**Frida Kahlo** Oil Painting

**Biography** July 6, 1907 - July 13, 1955

Frida Kahlo was born in Coyocacán, Mexico in 1907. She lived with her mom, Juan, and three sisters. When she was 6 she was infected with a disease called polio, and when she was 18 she was in a very bad traffic accident that left her in a lot of pain. She spent much of her time in bed recovering in the months that followed the accident.

After her traffic accident, her parents bought her painting equipment as a way to keep her busy. Her father was a photographer, so art had always been a part of her life. Painting became a way for her to express her feelings. Frida often painted self-portraits by looking in a mirror. Many of those paintings are famous today. Her life was difficult at times and she suffered a lot of pain, but Frida worked hard to achieve her dreams.

**Famous Works:**

- [Self-Portrait - Dedicated to Dr. Eloesser, 1940](#)
- [Self-Portrait with Thorn Necklace and Blue Flower, 1940](#)
- [Henry Ossawa Tanner, 1940](#)

**Fun Facts:**

- Her full name was Magdalena Carmen Frida Kahlo y Calderón.
- Before becoming an artist, she thought of becoming a doctor.
- Her father was German, and her name means "passion" in German.

**Famous Quote:**

"The only thing I know is that I paint because I need to."

**QR Code:** Scan for more information

©2015 by Learn Preschool

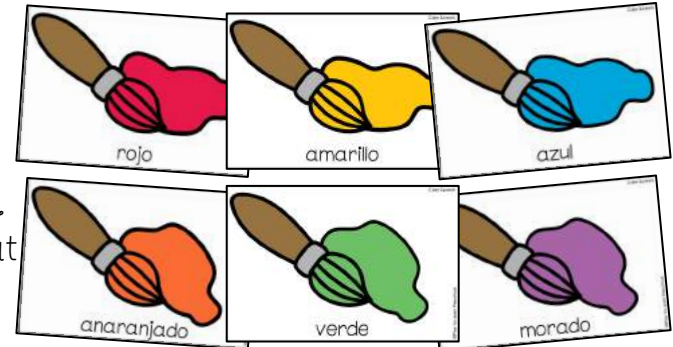

### Literacy Extension:

Read "I Ain't Gonna Paint No More" by Karen Beaumont.

**Colorful Self-Portraits** Day 2 of a Project

**Step 1:** Take a close up photo of each student. Print each photo in black and white on cardstock.

**Step 2:** Gather the materials:

- washable tempera paint
- sponges/paper plates
- paintbrushes
- a cup of water
- paper towels

**Step 3:** Model how to paint different colored flowers or other details on the printed photo. Remind students not to cover up too much of their face.

**Step 4:** Allow time for students to create their own Frida Kahlo inspired artwork using their printed photos.

©2015 by Learn Preschool



# Frida Kahlo

Oil  
Painting

## Biography

July 6, 1907

July 13, 1954

Frida Kahlo was born in Coyoacán, Mexico in 1907. She lived with her mom, dad, and three sisters. When she was 6 she was infected with a disease called polio, and when she was 18 she was in a very bad traffic accident that left her in a lot of pain. She spent much of her time in bed recovering in the months that followed the accident.

After her traffic accident, her parents bought her painting supplies as a way to keep her busy. Her father was a photographer, so art had always been a part of her life. Painting became a way for her to express her feelings. Frida often painted self-portraits by looking in a mirror. Many of those paintings are famous today. Her life was difficult at times and she suffered a lot of pain, but Frida worked hard to achieve her dreams.

## Famous Works:

- [Self-Portrait](#) - Dedicated to Dr. Eloesser, 1940
- [Self-Portrait with Thorn Necklace and Hummingbird](#), 1940

## Fun Facts:

- Her full name was Magdalena Carmen Frida Kahlo y Calderón.
- Before becoming an artist, she thought of becoming a doctor.
- Her father was German, and her name means “peace” in German.

## Famous Quote:

“The only thing I know is that I paint because I need to.”

Scan for more information

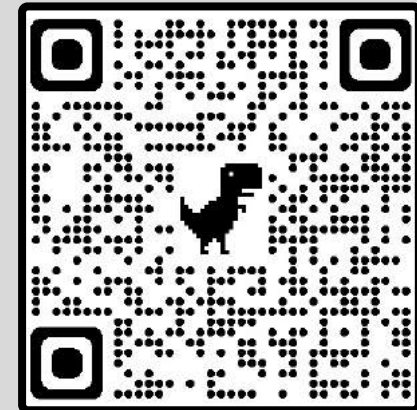

[https://kids.kiddle.co/Frida\\_Kahlo](https://kids.kiddle.co/Frida_Kahlo)

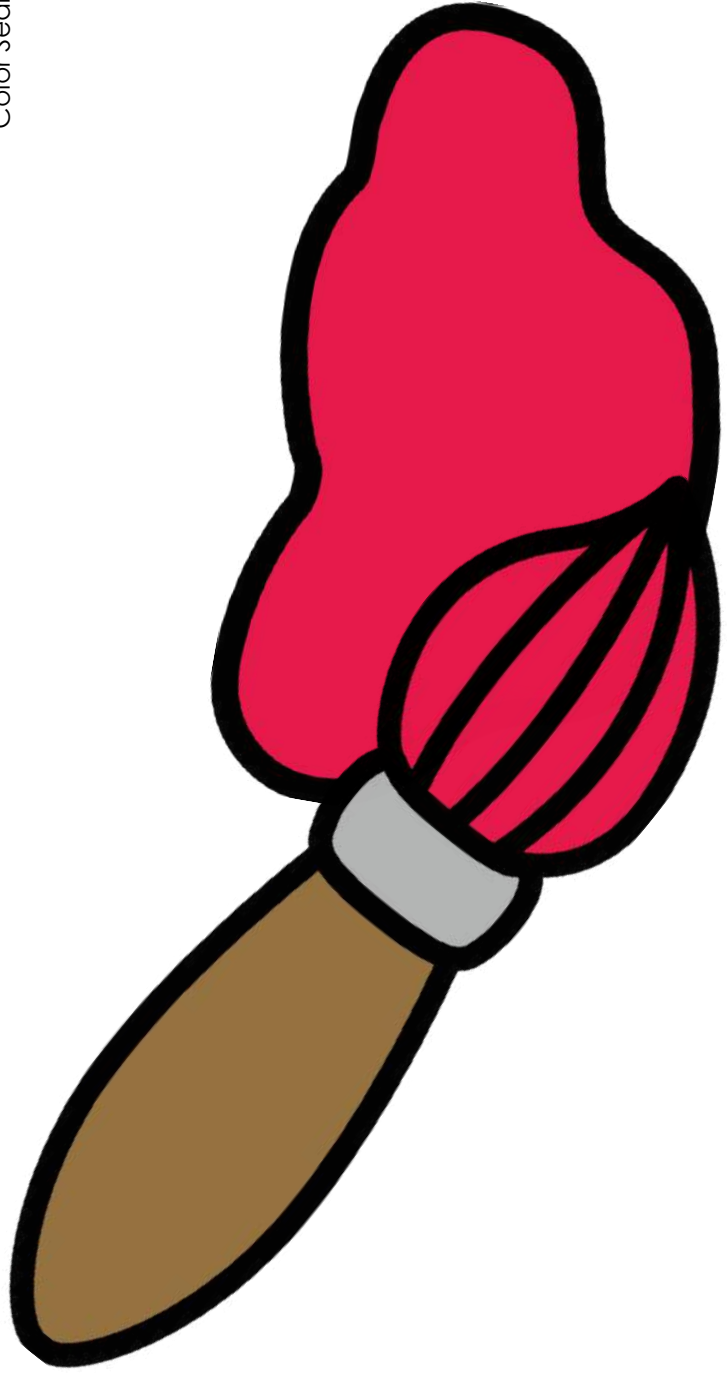

rojo

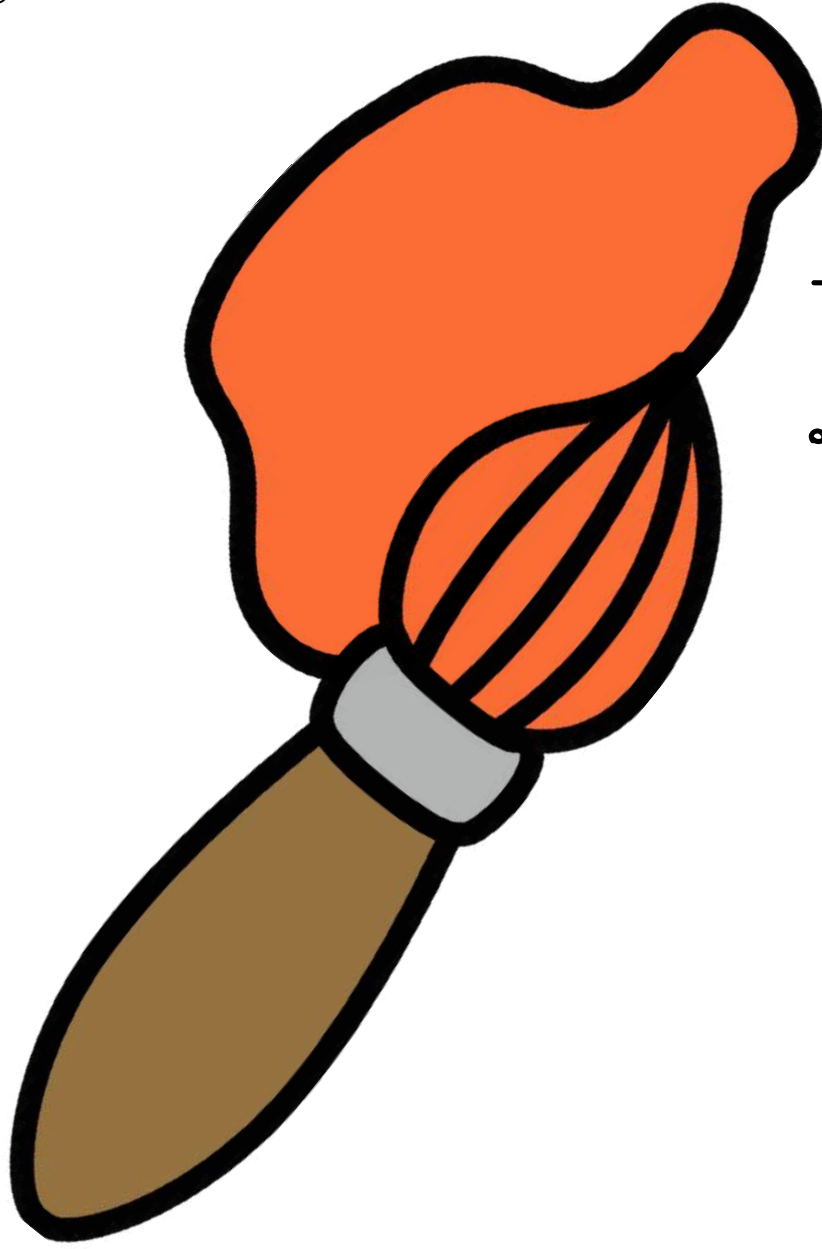

anaranjado

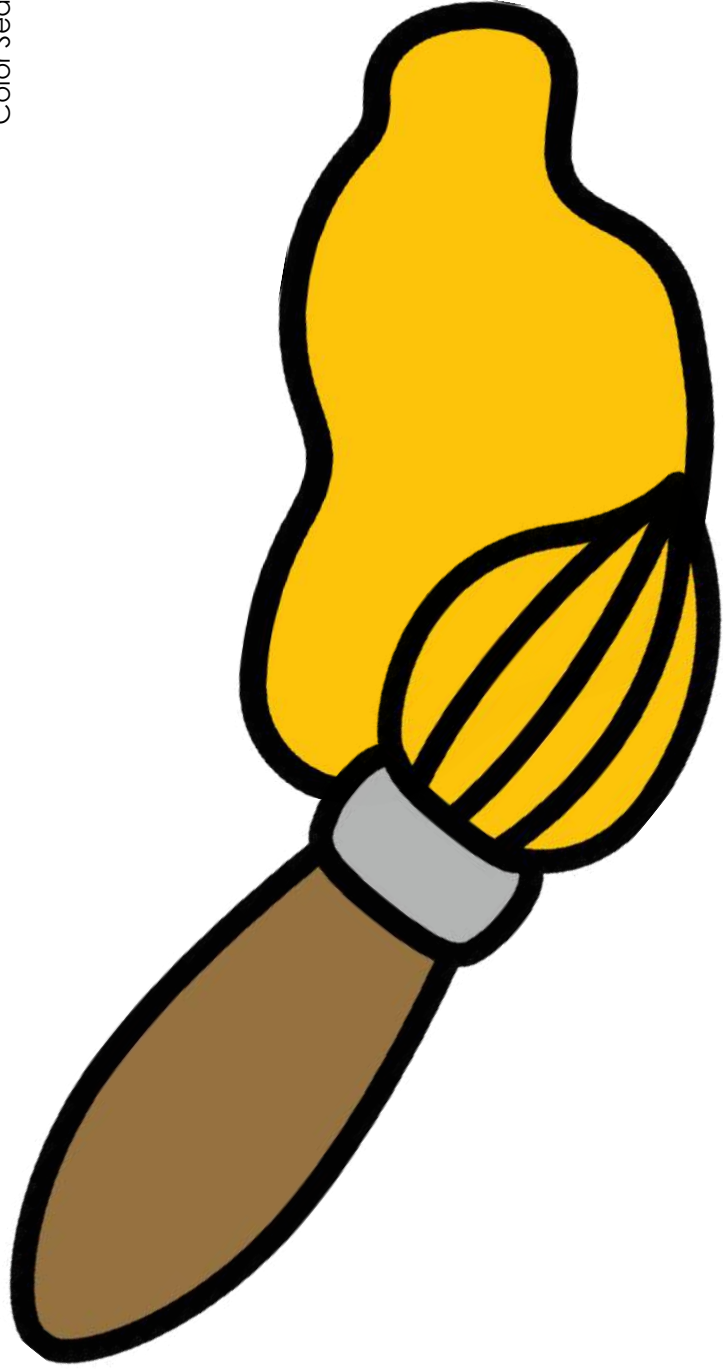

amarillo

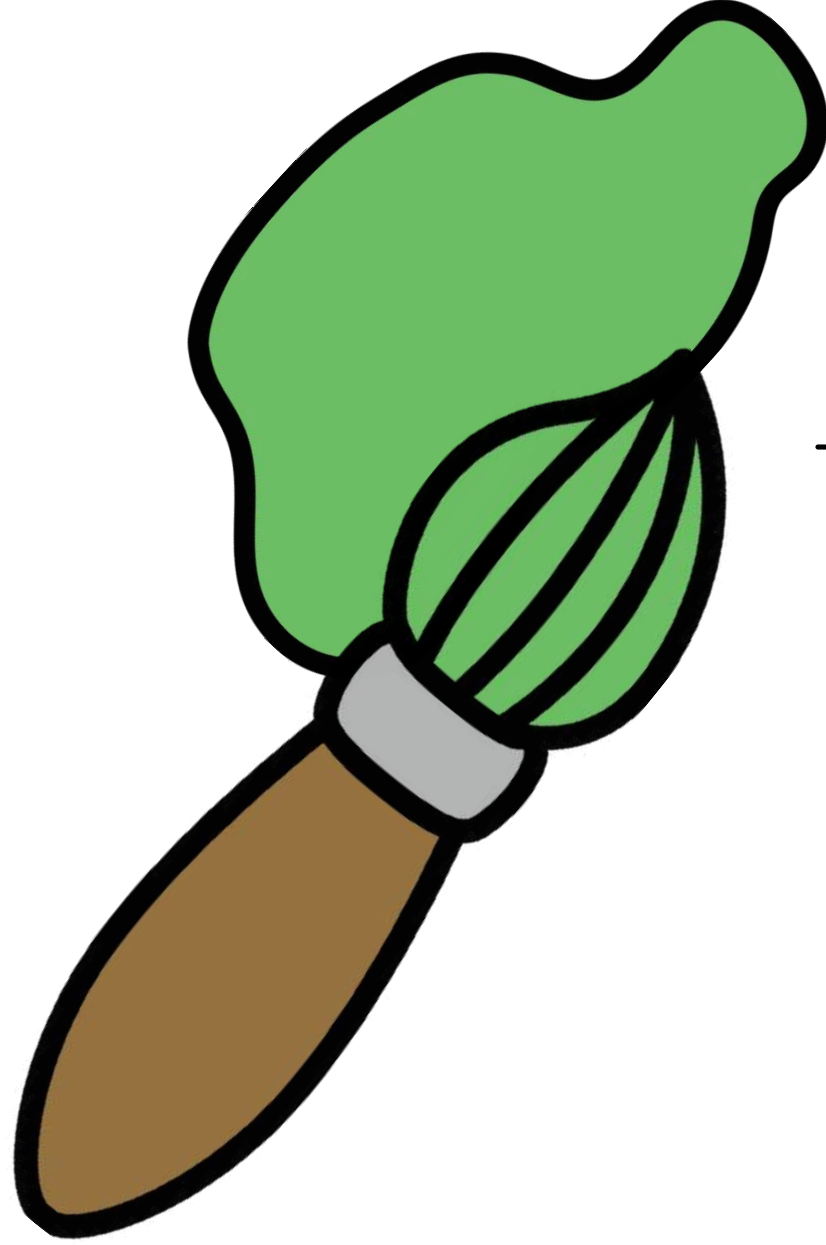

verde

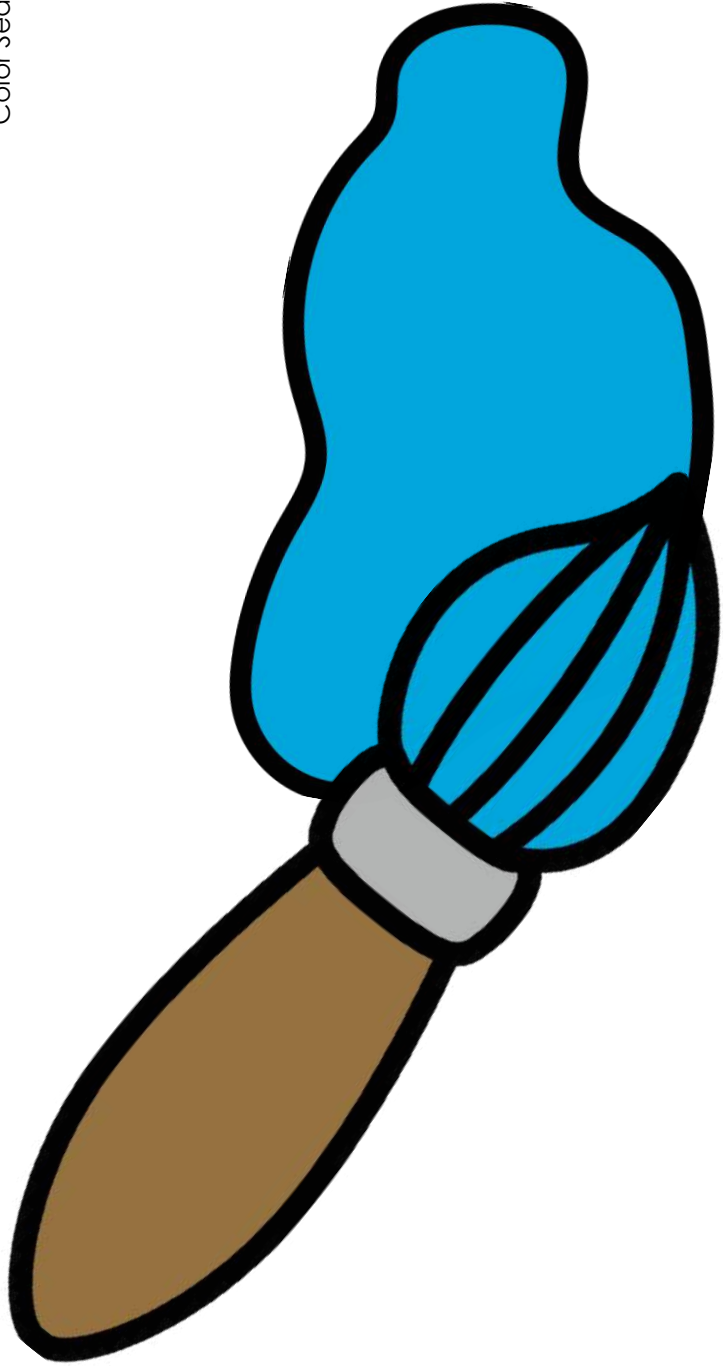

azul

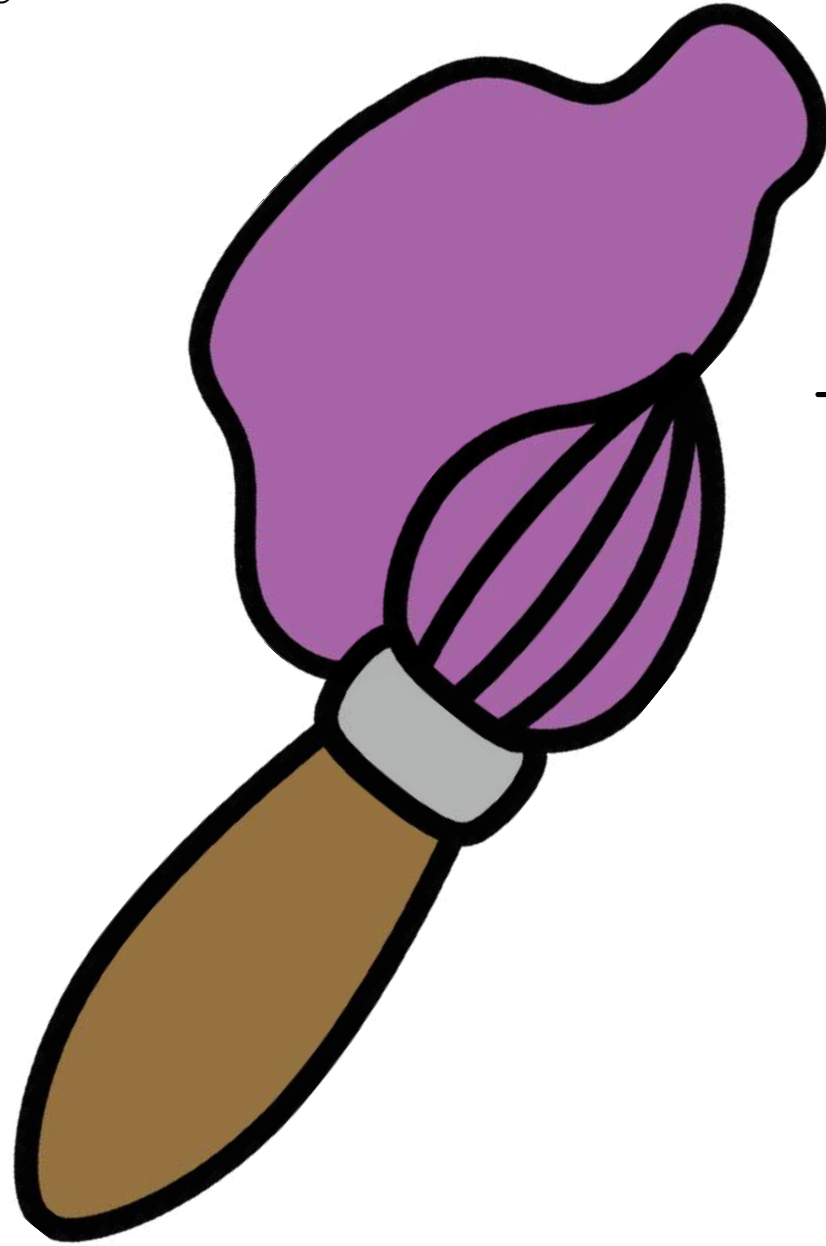

morado

These things



are  
**BLACK & WHITE.**

These things



have a lot of  
**COLORS.**



rainbow

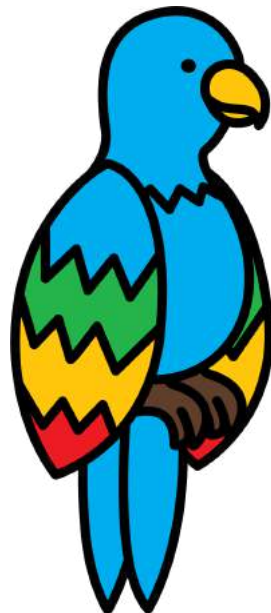

parrot

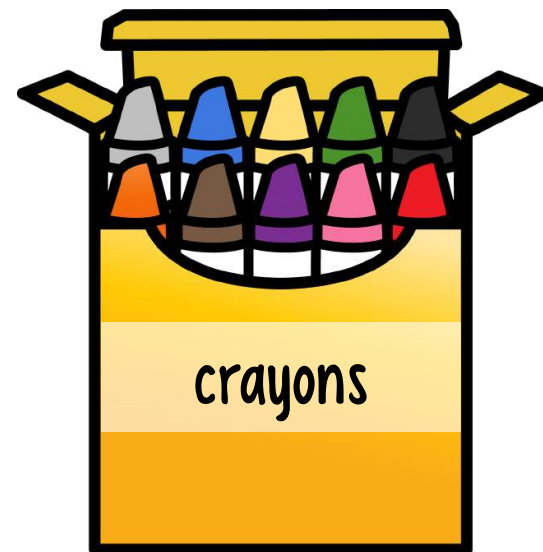

crayons



balloons

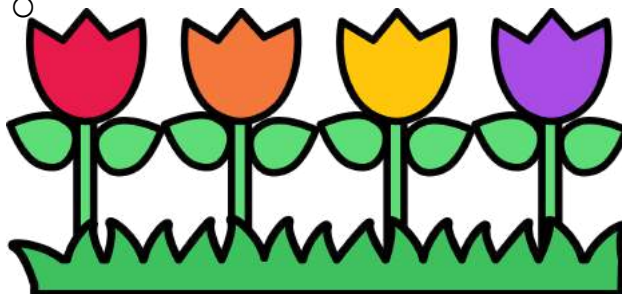

flowers

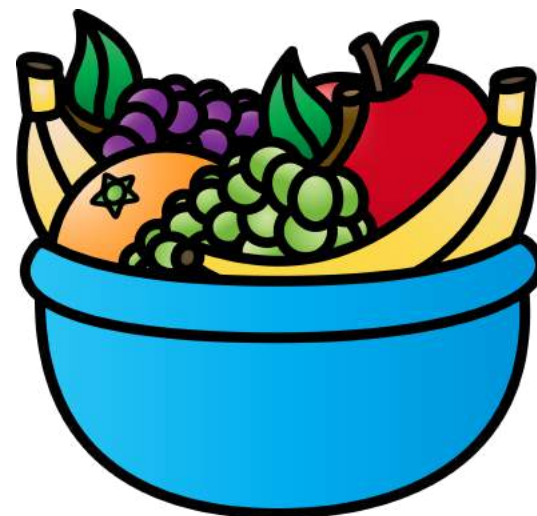

fruit

Color/BW Sort



sprinkles

Color/BW Sort



candy

Color/BW Sort



leaves

Color/BW Sort



panda

Color/BW Sort

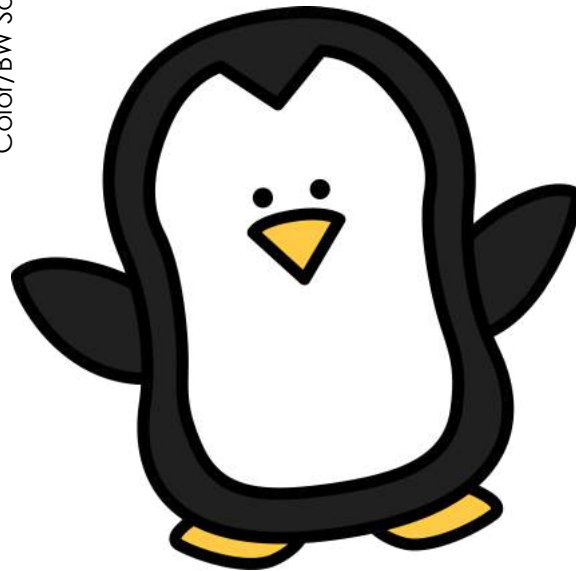

penguin

Color/BW Sort

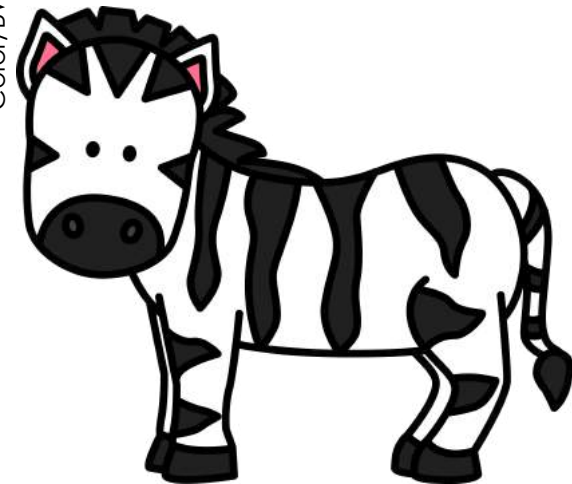

zebra

Color/BW Sort

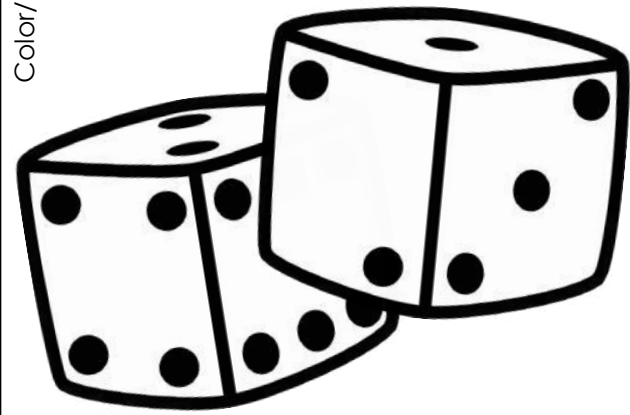

dice

Color/BW Sort



soccer ball

Color/BW Sort



skunk

Color/BW Sort



newspaper

Color/BW Sort



dalmatian

Color/BW Sort

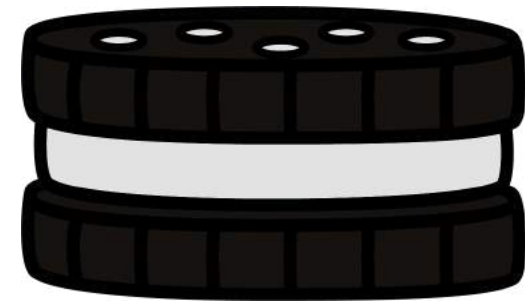

sandwich cookie

# Colorful Self-Portraits

Day 2  
Art  
Project

Step  
#1

Take a close up photo of each student. Print each photo in black and white on cardstock.

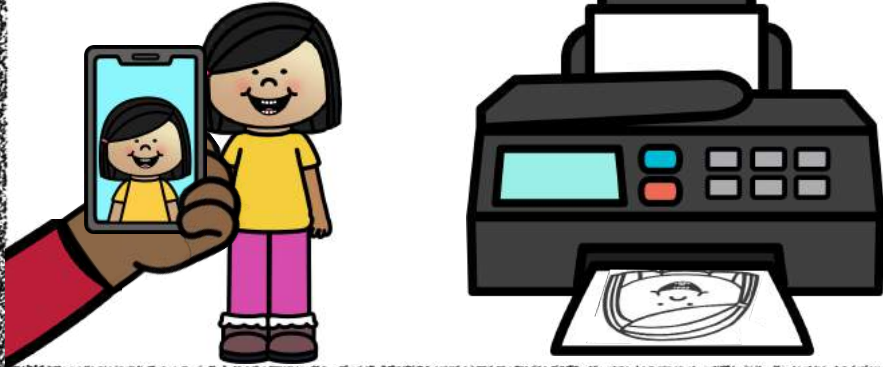

Step  
#2

Gather the materials:

- washable tempera paint
- paper plates/palettes
- paintbrushes & a cup of water
- paper towels



Step  
#3

Model how to paint different colored flowers or other details on the printed photo. Remind students not to cover up too much of their face.

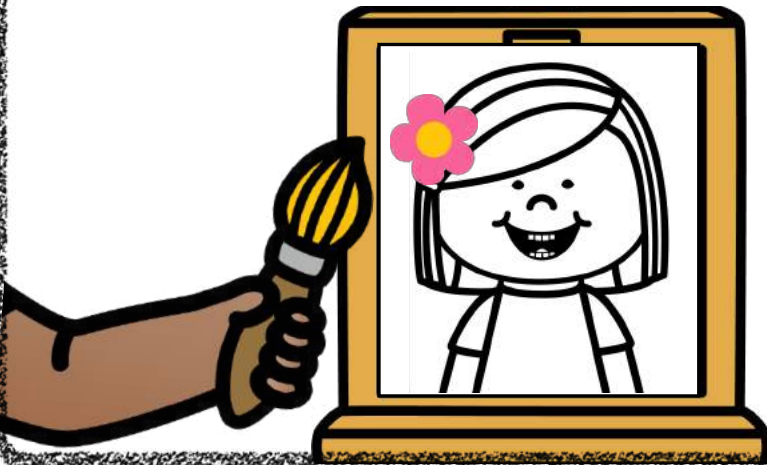

Step  
#4

Allow time for students to create their own Frida Kahlo inspired artwork using their printed photos.

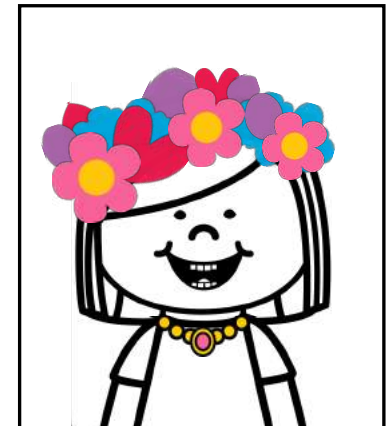
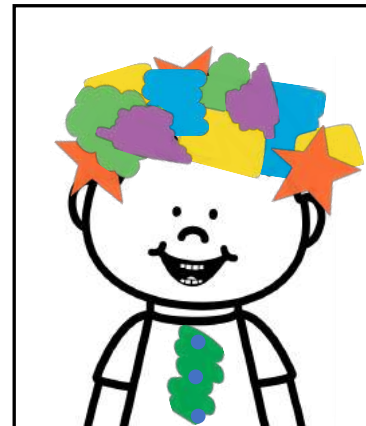

# Andy Warhol

An-dee Wor-haal

Day 3  
Lesson  
Plans

Andy Warhol is an American artist who helped create the style of art known as “pop art.”

## Objectives:

- The students will count sets to 10 and make combinations of objects to create each set.
- The students will identify shapes and colors.
- The students will use fine motor skills to produce works of art.

## Activities:

1. Introduce Andy Warhol by reading his biography and showing some of his famous paintings. (Links on the biography page.)
2. Recite the “Ten Little Crayons” poem. Use the included cards or a real-life crayon box to remove crayons as the poem progresses.
3. Play the Pop Art carpet game.
4. Follow the steps to create an Andy Warhol inspired pop art masterpiece.

### Andy Warhol

**Pop Art**

#### Biography

August 6, 1928  
Feb 22, 1987

Andy Warhol was born in Pittsburgh, Pennsylvania, and lived with his mom, dad, and two older brothers. When Andy was 6, he got sick and had to stay in bed for a while. To entertain him while he recovered, his family taught him how to draw.

After finishing high school, Andy was the first person in his family to attend college. He went to the Carnegie Institute of Technology and then moved to New York to become an illustrator. He created advertisements, books, record albums, and more. While he enjoyed this work, he began to think of how else he could expand his art.

In the 1960s, Andy began painting in a new style that became known as “Pop Art.” This type of art used things like soup cans that he would paint over and over. It is still very popular today.

#### Famous Works:

- *Self-Portrait* - 1966
- *Marilyn Monroe* - 1967
- *Comedian's Faces* - 1969

**Fun Facts:**

- His birth name was Andrew Warhola. He dropped the “a” in college.
- In addition to painting, he also produced around 50 movies.
- His paintings are very valuable today. One sold for over \$100 million in 2013!

**Famous Quote**

“Something has its beauty, but not everyone sees it.”

Scan for more information



©Play to Learn Preschool

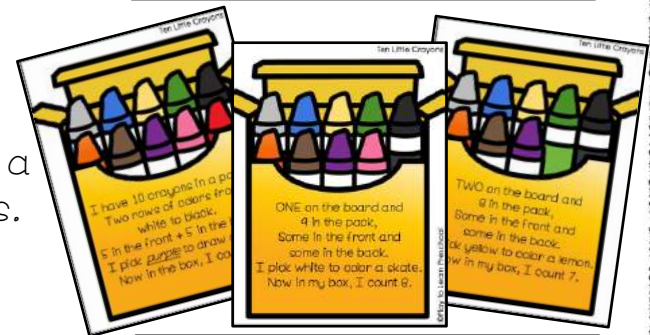

## To Play the Game:

- Line up the pictures of the popcorn. Pick the right number of cards for your students. Identify the colors and shapes together.
- Hide the paintbrush under one of the pieces of popcorn and recite the poem to find it.
- Children guess where the paintbrush is hiding by identifying the color and/or shape.

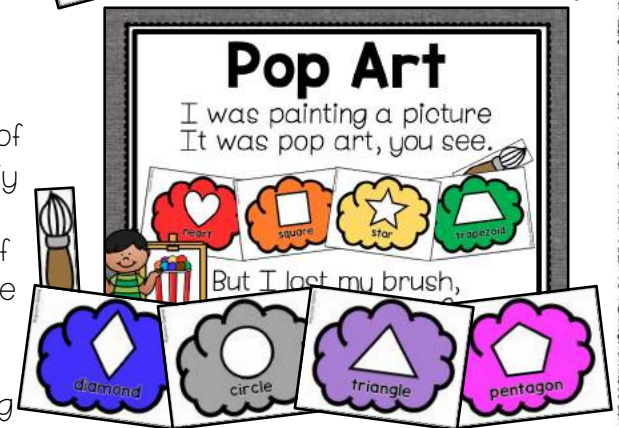

## Literacy Extension:

Read “Uncle Andy’s Cats” by James Warhola.

### Pop Art

**Day 3 Art Project**

**Step 1** Print a copy of the Betty Boop page for each student. Do not cut apart.

*\* Alternatively, take photos of special things around the classroom. Print in black and white. It helps on page.*

**Step 2** Model how to color each of the 11 pictures using 2-3 colors for each.

**Step 3** Gather the materials: printed pages showing 11 different images, colored pencils or markers.

**Step 4** Provide time for students to create their own Andy Warhol inspired artwork using their printed photos.

©Play to Learn Preschool

# Andy Warhol

Pop  
Art

## Biography

August 6, 1928

Feb. 22, 1987

Andy Warhol was born in Pittsburgh, Pennsylvania. He lived with his mom, dad, and two older brothers. When Andy was 6, he got sick and had to stay in bed for a while. To entertain him while he recovered, his family taught him how to draw.

After finishing high school, Andy was the first person in his family to attend college. He went to the Carnegie Institute of Technology and then moved to New York to become an illustrator. He created advertisements, books, record albums, and more. While he enjoyed this work, he began to think of how else he could expand his art.

In the 1960s, Andy began painting in a new style that became known as "Pop Art." This type of art used things like soup cans that he would paint over and over. It is still very popular today.

## Famous Works:

- [Self-Portrait](#) – 1966
- [Marilyn Monroe](#) – 1967
- [Campbell's Soup](#) – 1968

## Fun Facts:

- His birth name was Andrew Warhola. He dropped the "a" in college.
- In addition to painting, he also produced around 60 movies.
- His paintings are very valuable today. One sold for over \$100 million in 2013!

## Famous Quote:

"Everything has its beauty, but not everyone sees it."

Scan for more information

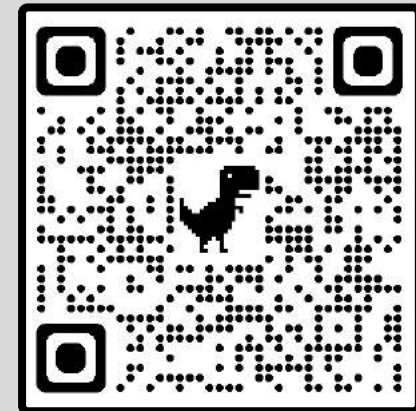

[https://kids.kiddle.co/Andy\\_Warhol](https://kids.kiddle.co/Andy_Warhol)

# Ten Little Crayons

Addition Poem from Artfelt.net

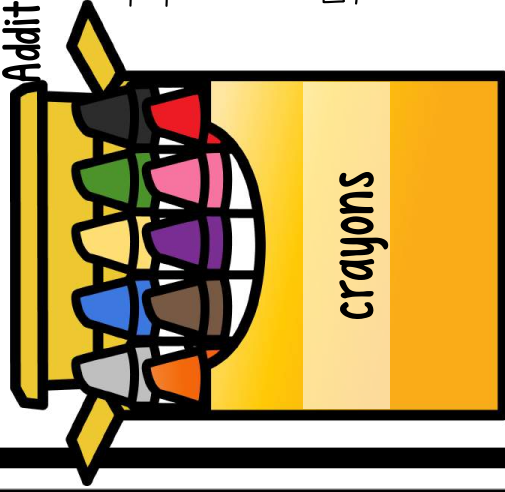

I have 10 crayons in a pack,  
Two rows of colors  
from white to black.  
5 in the front + 5 in the back.  
I pick purple to draw a line.  
Now in the box, I count 9.

ONE on the board and 9 in the pack,  
Some in the front and some in the back.  
I pick white to color a skate.  
Now in my box, I count 8.

TWO on the board and 8 in the pack,  
Some in the front and some in the back.  
I pick yellow to color a lemon.  
Now in my box, I count 7.

THREE on the board and 7 in the pack.  
Some in the front and some in the back.  
I pick red to draw some bricks.  
Now in my box, I count 6.

FOUR on the board and 6 in the pack.  
Some in the front and some in the back.  
I pick green to color a hive.  
Now in my box, I count 5.

FIVE on the board and 5 in the pack.  
Some in the front and some in the back.  
I pick brown to make a door.  
Now on the board, I count 4.

SIX on the board and 4 in the pack,  
Some in the front and some in the back.  
I pick gray to make a key.  
Now in my box, I count 3.

SEVEN on the board and 3 in the pack,  
Some in the front and some in the back.  
I pick blue to make a shoe.  
Now in my box, I count 2.

EIGHT on the board and 2 in the pack,  
Some in front and some in the back.  
I pick orange to make a sun.  
Now in my box, I count 1.

NINE on the board and 1 in the pack,  
One in the front and none in the back.  
I pick black to draw a round hole.

Now in my box, I count ZERO.  
I have 10 crayons and an empty pack.  
Into two rows, I'll put them all back.



TWO on the board and  
8 in the pack,  
Some in the front and  
some in the back.  
I pick yellow to color a lemon.  
Now in my box, I count 7.



I have 10 crayons in a pack,  
Two rows of colors from  
white to black.  
5 in the front + 5 in the back.  
I pick purple to draw a line.  
Now in the box, I count 9.

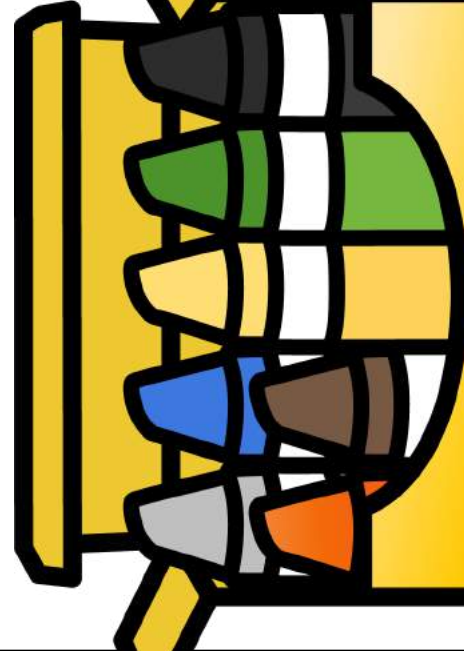

THREE on the board and  
7 in the pack.  
Some in the front and  
some in the back.  
I pick red to draw  
some bricks.  
Now in my box, I count 6.

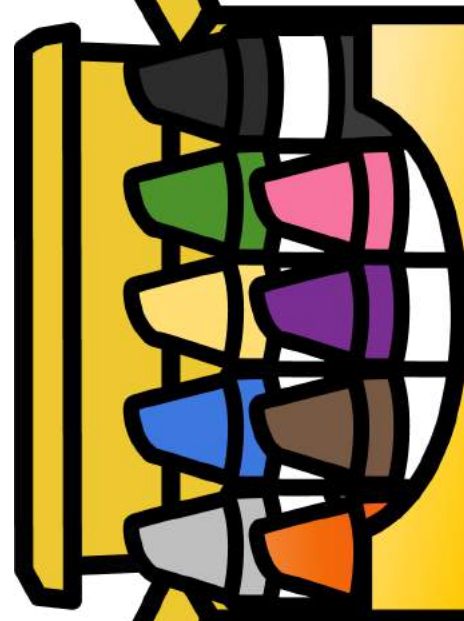

ONE on the board and  
9 in the pack,  
Some in the front and  
some in the back.  
I pick white to color a skate.  
Now in my box, I count 8.

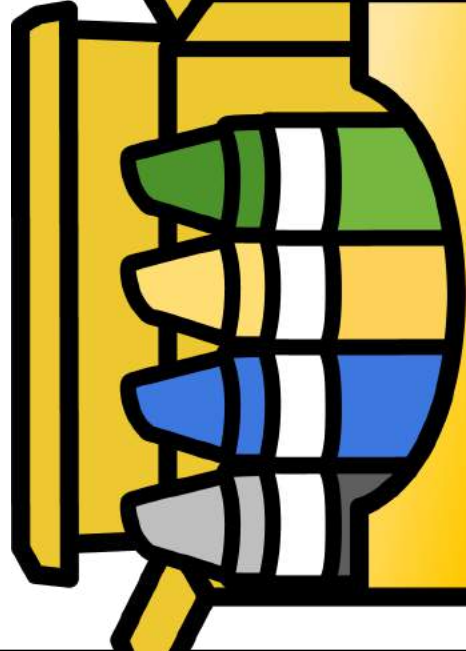

SIX on the board and  
 4 in the pack,  
 Some in the front and  
 some in the back.  
 I pick gray to make a key.  
 Now in my box, I count 3.



FOUR on the board and  
 6 in the pack.  
 Some in the front and  
 some in the back.  
 I pick green to color a chive.  
 Now in my box, I count 5.

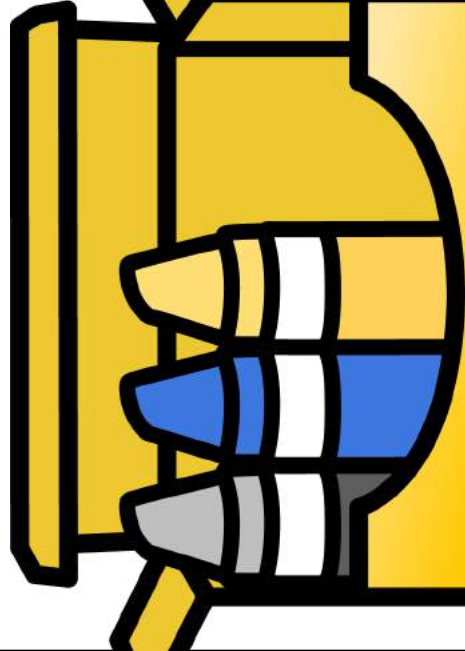

SEVEN on the board and  
 3 in the pack,  
 Some in the front and  
 some in the back.  
 I pick blue to make a shoe.  
 Now in my box, I count 2.

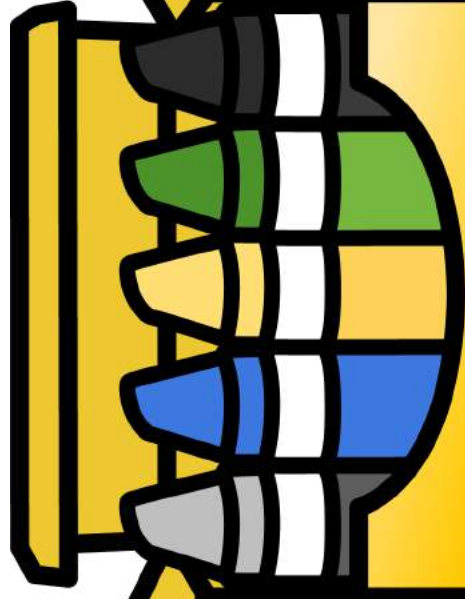

FIVE on the board and  
 5 in the pack.  
 Some in the front and  
 some in the back.  
 I pick brown to make a door.  
 Now on the board, I count 4.

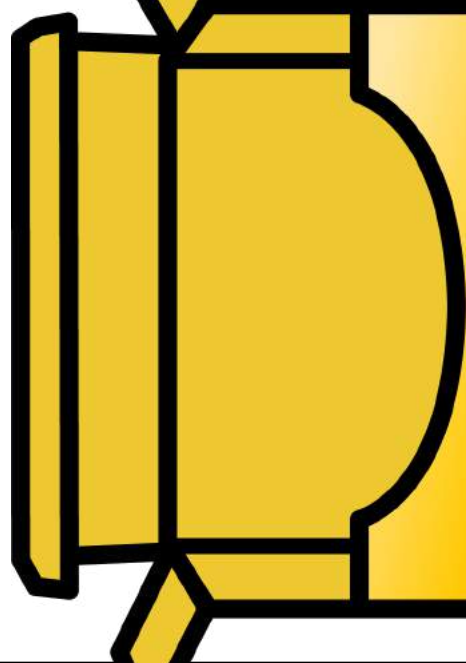

Now in my box,  
I count ZERO.  
I have 10 crayons and  
an empty pack.  
Into two rows,  
I'll put them all back.

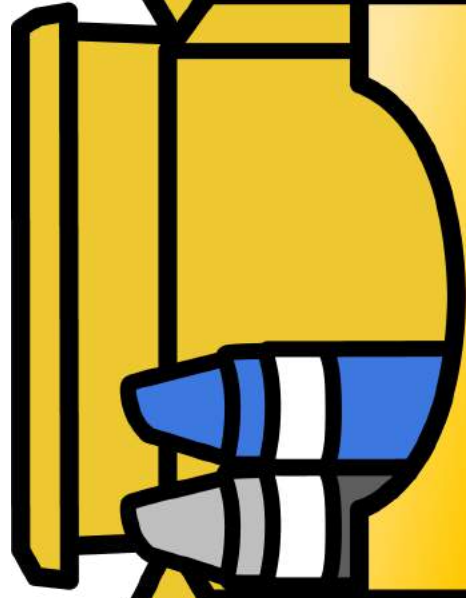

EIGHT on the board and  
2 in the pack,  
Some in front and  
some in the back.  
I pick orange to make a sun.  
Now in my box, I count 1.

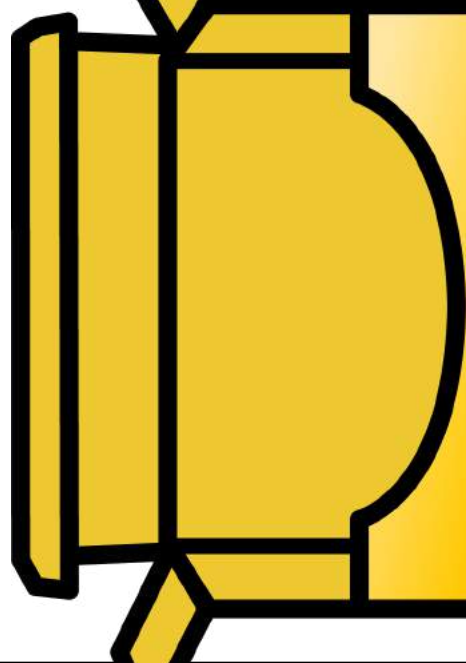

Now in my box,  
I count ZERO.  
I have 10 crayons and  
an empty pack.  
Into two rows,  
I'll put them all back.

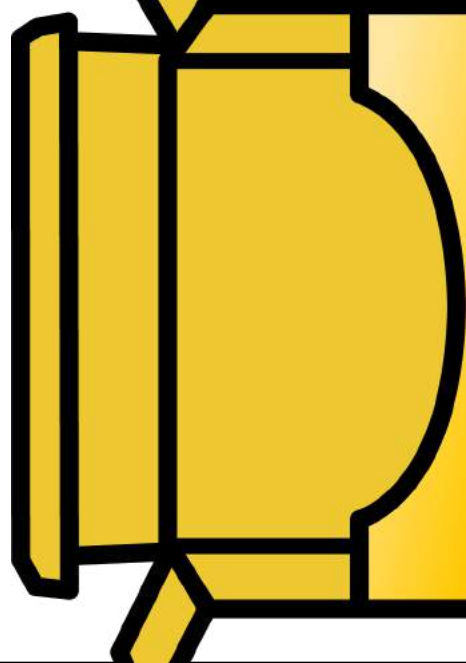

Now in my box,  
I count ZERO.  
I have 10 crayons and  
an empty pack.  
Into two rows,  
I'll put them all back.

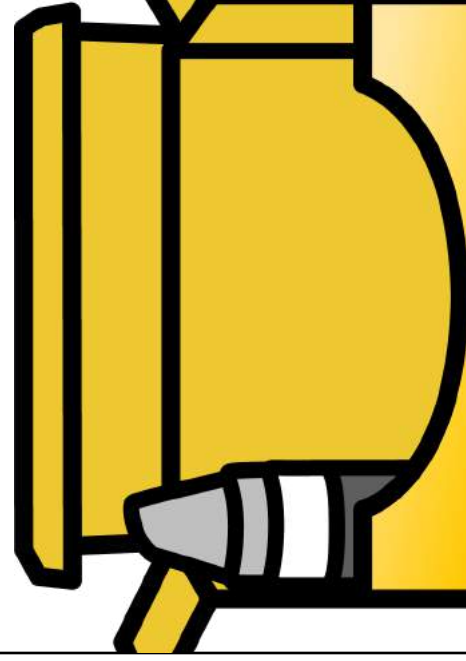

NINE on the board and  
1 in the pack,  
Some in the front and  
some in the back.  
I pick black to  
draw a round hole.

# Pop Art

I was painting a picture  
It was pop art, you see.

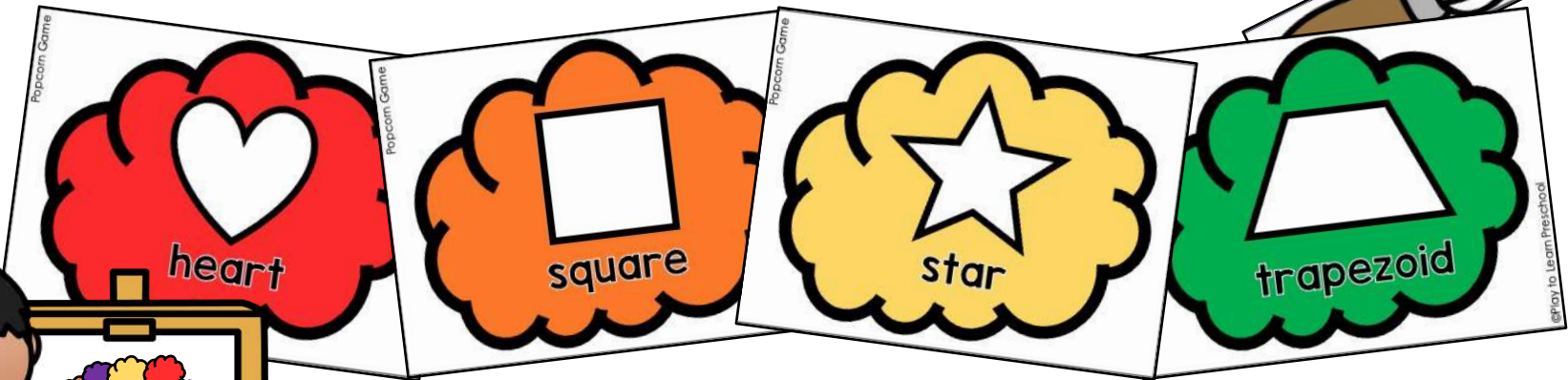

But I lost my brush,  
Where could it be?

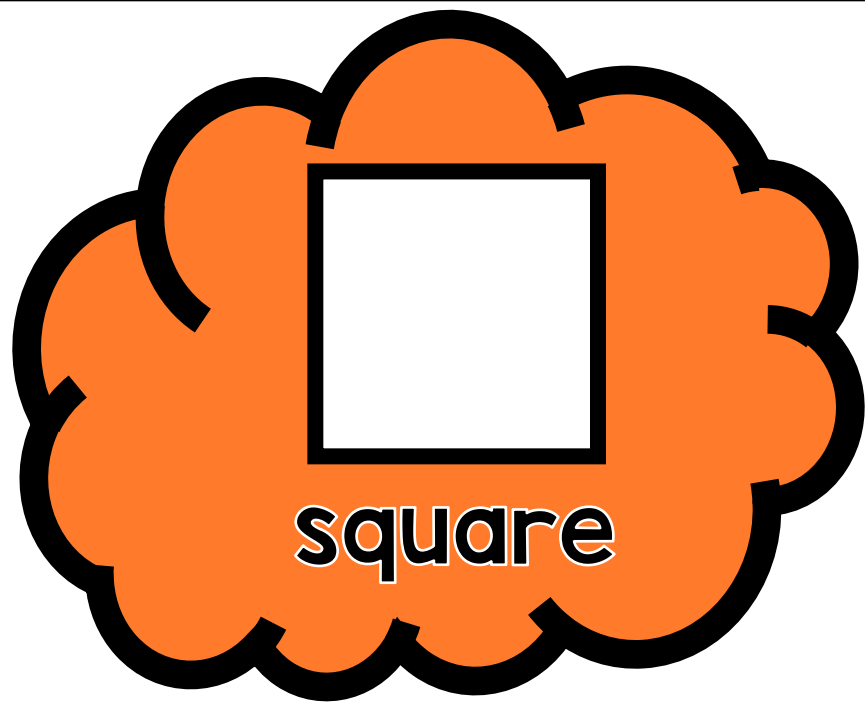
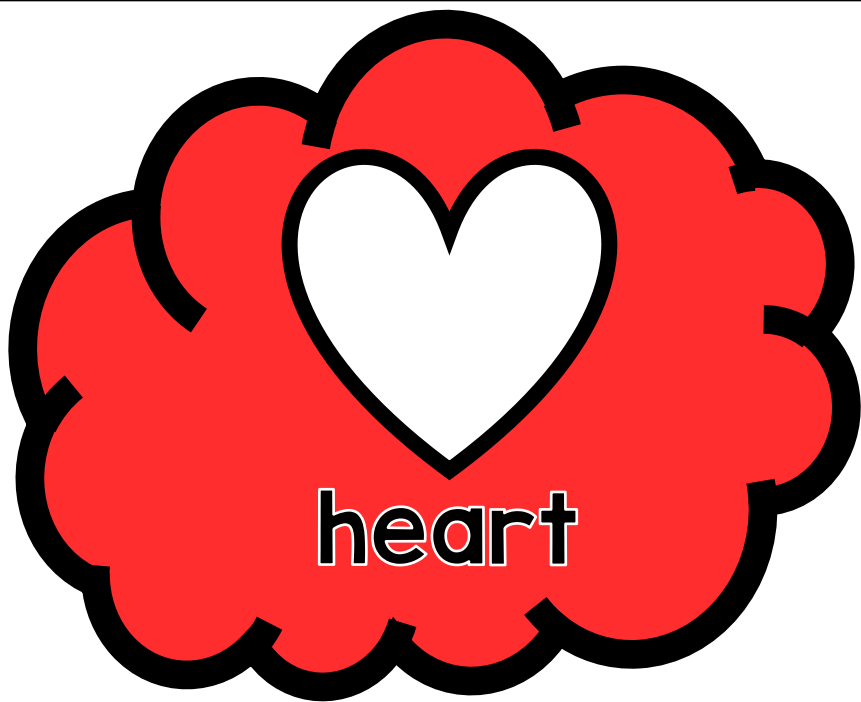

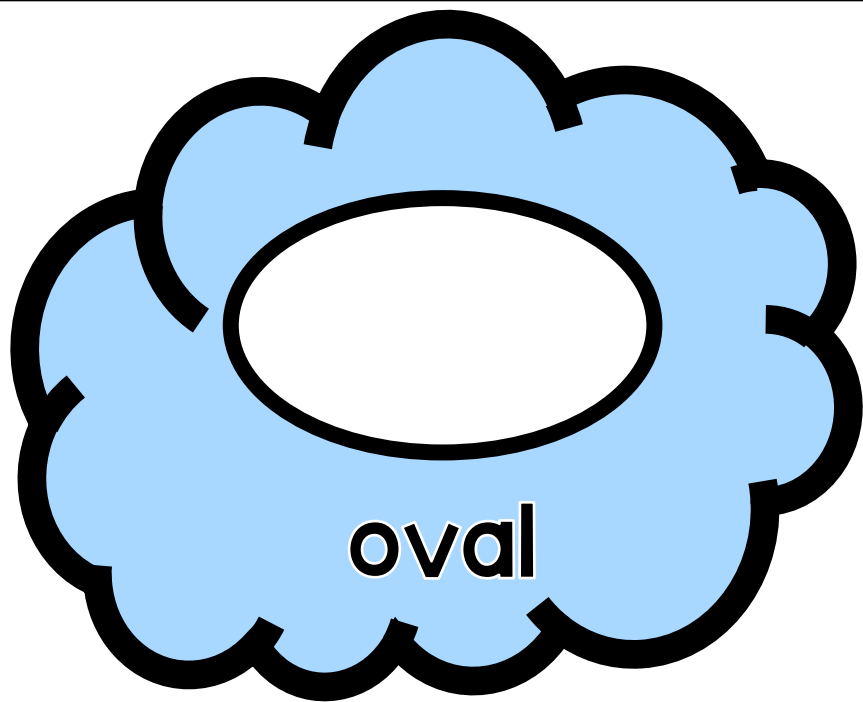

oval

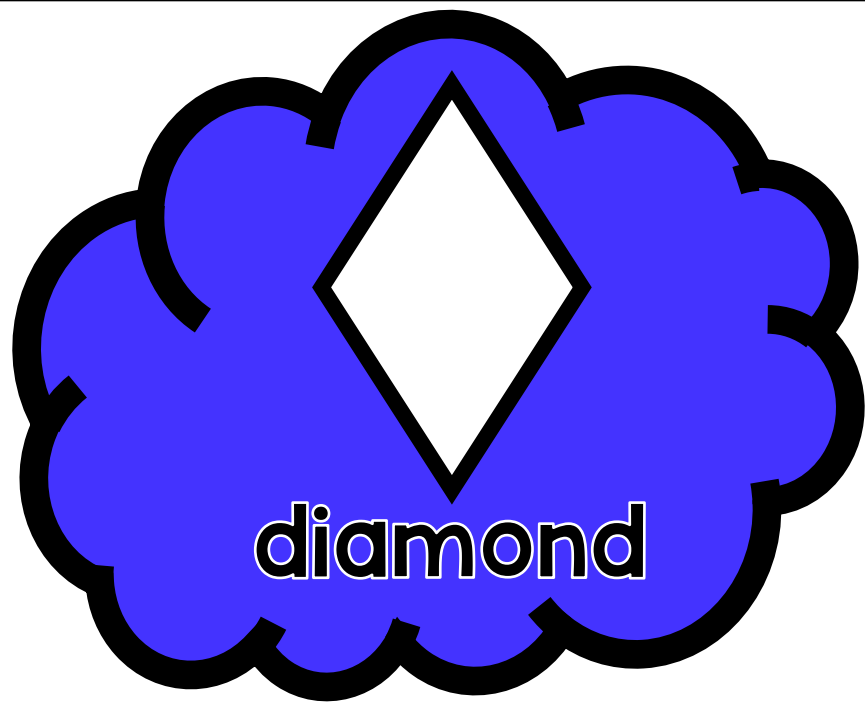

diamond

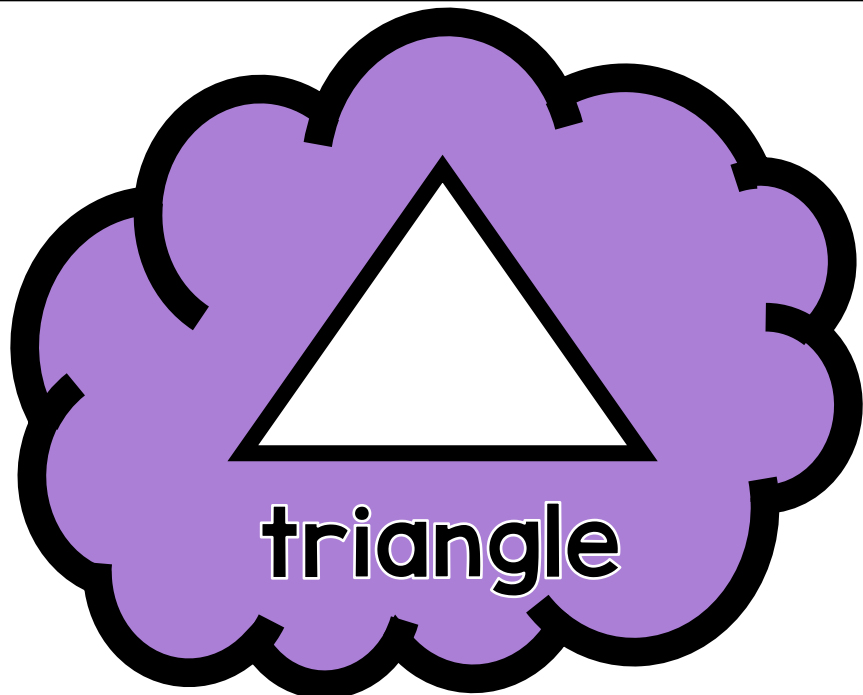

triangle

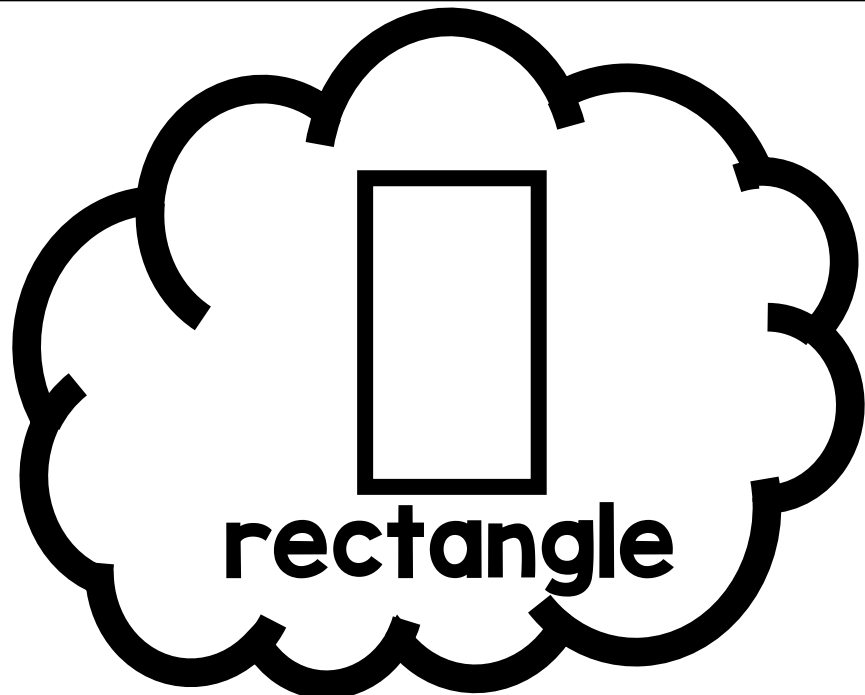

rectangle

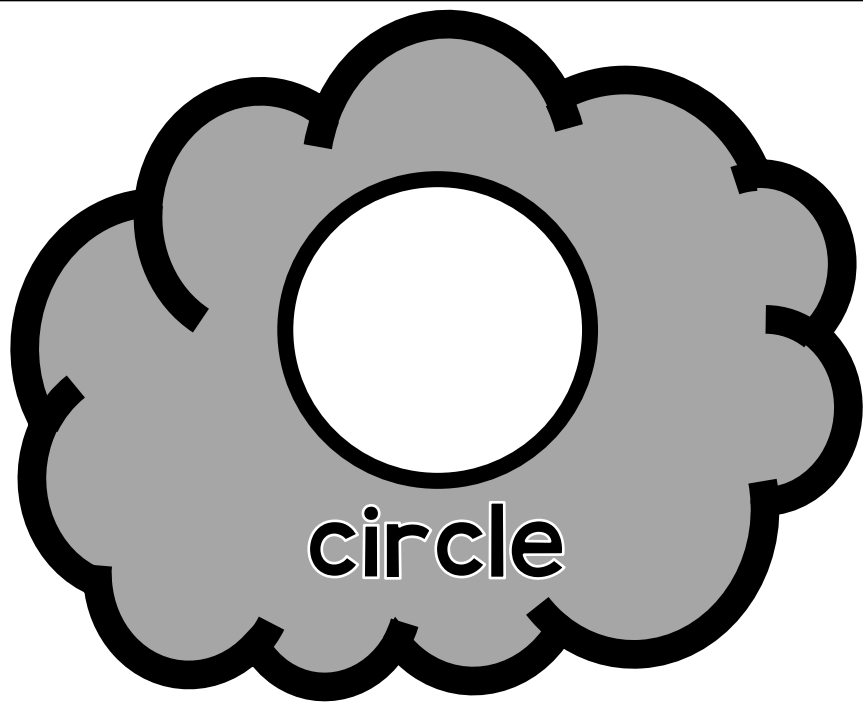

circle

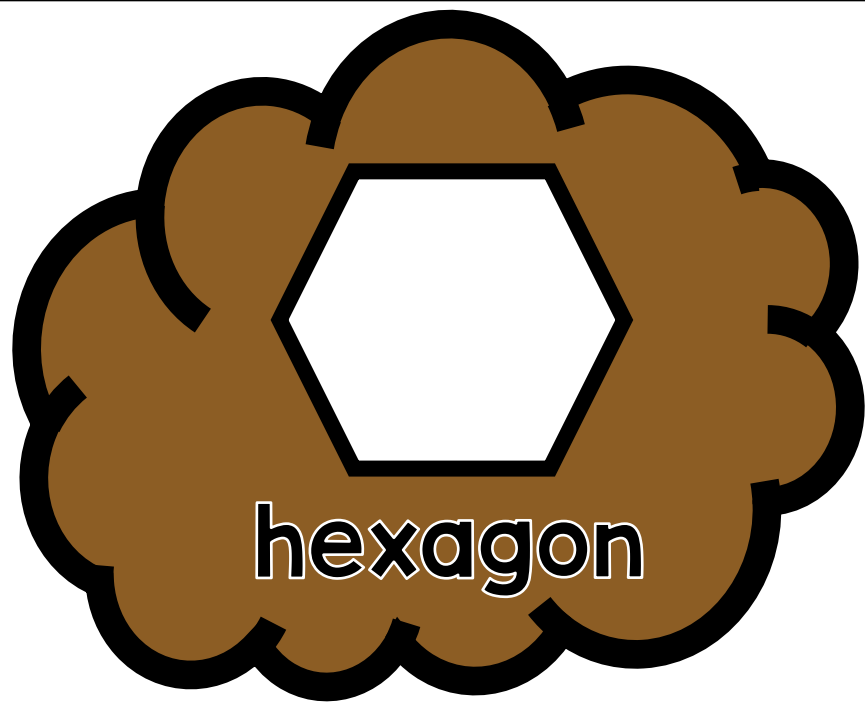

hexagon



pentagon

Cut out this brush.

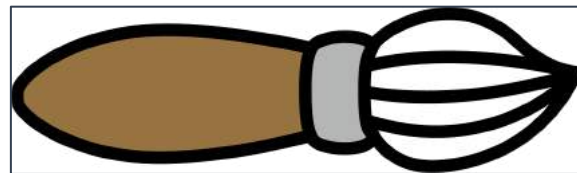

# Pop Art

Day 3  
Art  
Project

Step  
#1

Print a copy of the Betsy Blackbird page for each student. Do not cut apart.

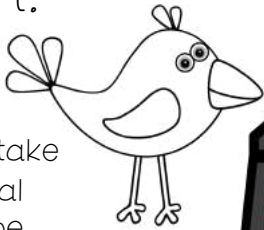

\* Alternatively, take photos of special things around the classroom. Print in black and white, 4 images per page.

Step  
#2

Gather the materials:

- printed pages showing 4 identical images
- crayons, colored pencils, or markers

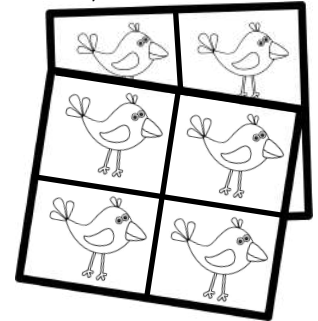
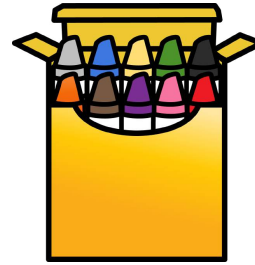

Step  
#3

Model how to color each of the 4 pictures using 2-3 colors for each.

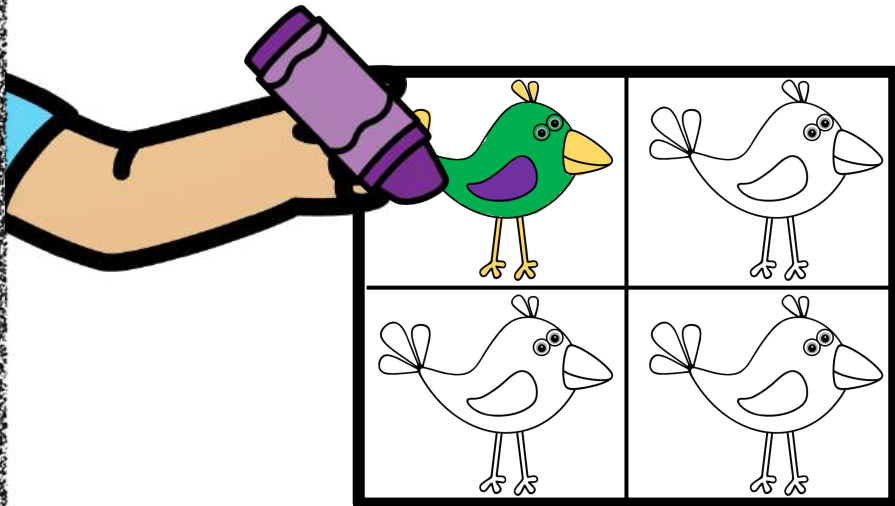

Step  
#4

Provide time for students to create their own Andy Warhol inspired artwork using their printed photos.

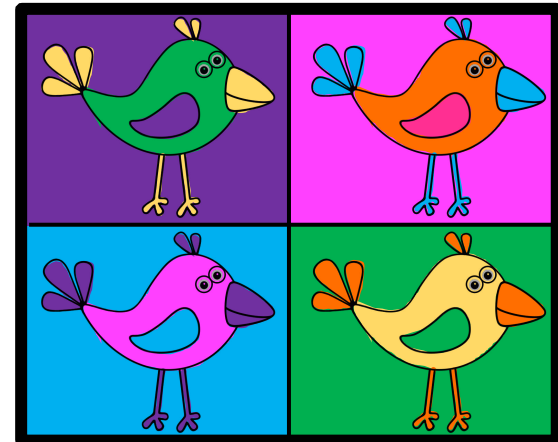

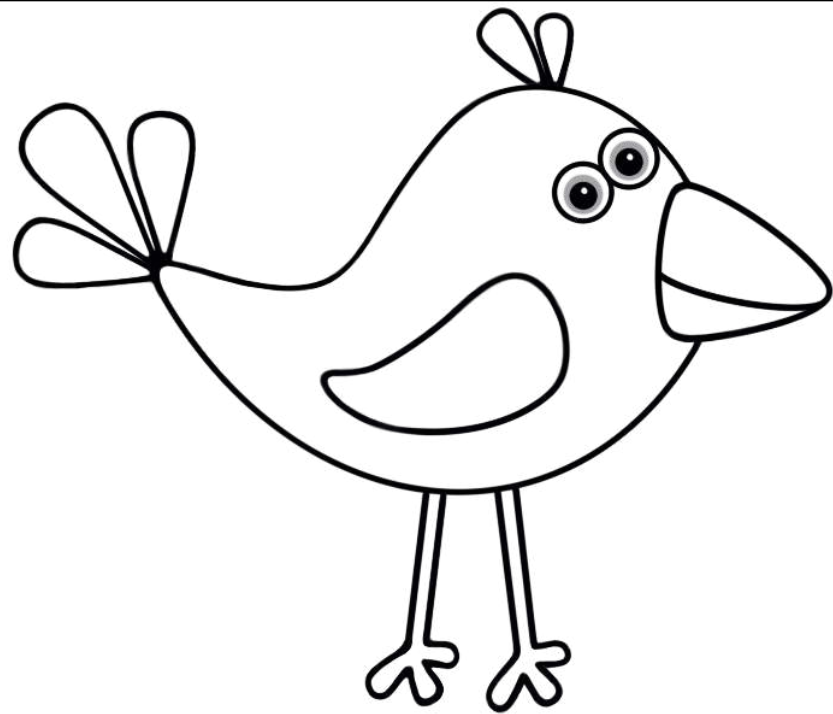
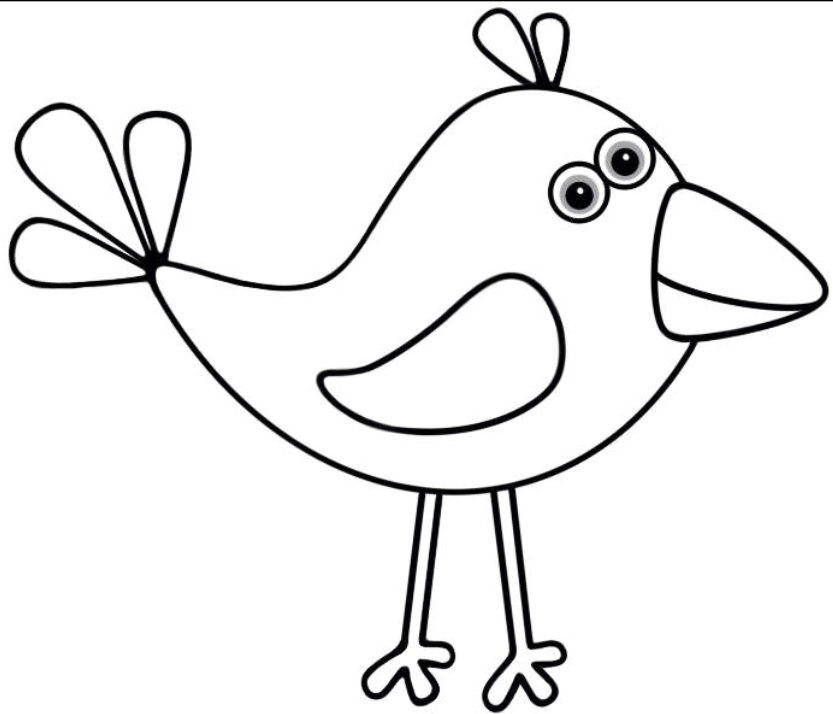
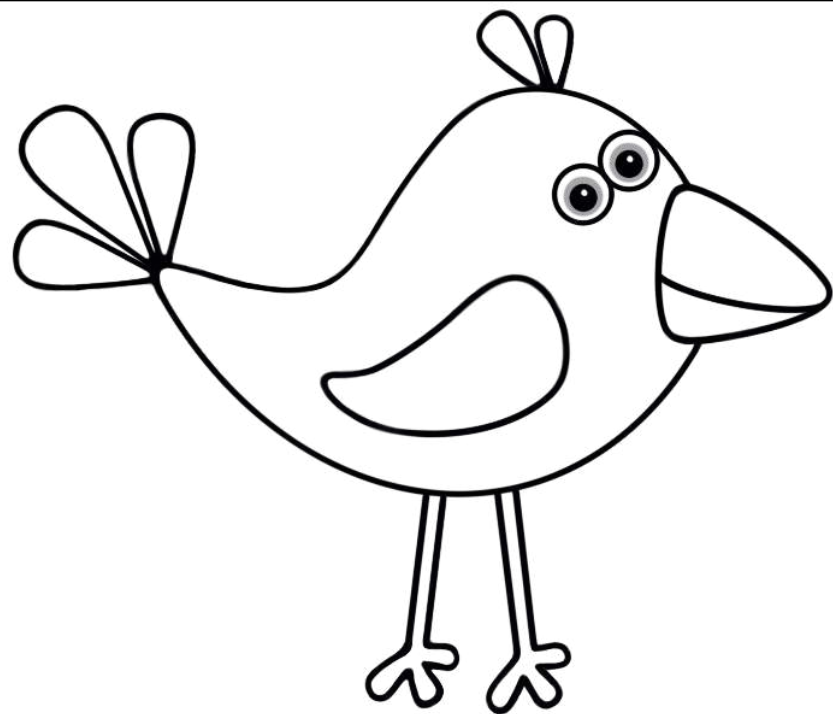
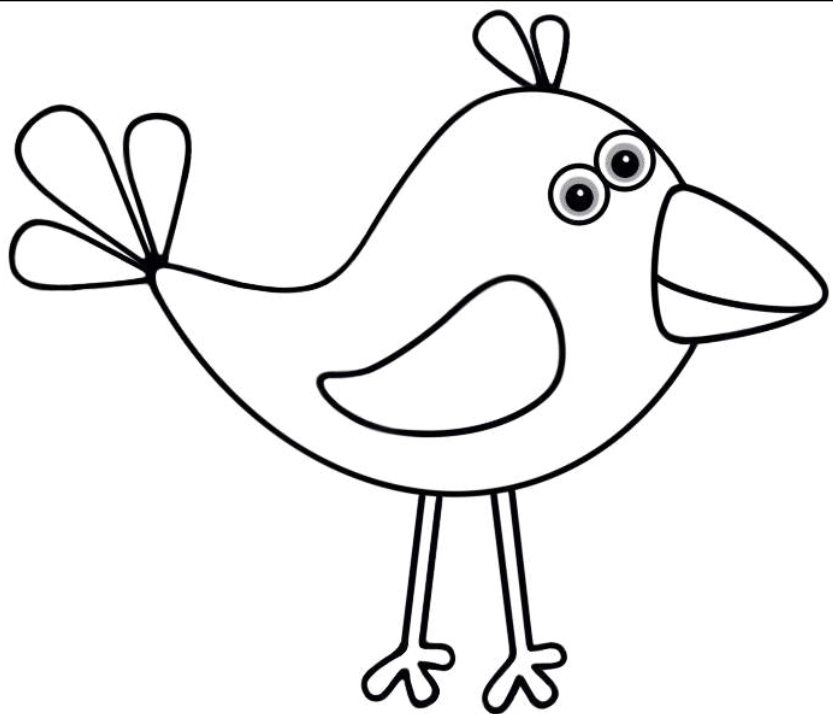

# Piet Mondrian

Peet Maan-dree-uhn

Day 4  
Lesson  
Plans

Piet Mondrian used horizontal (sideways) and vertical (up and down) lines to create unique works of art.

## Objectives:

- The students will play with words, sounds, and rhymes.
- The students will sort objects by property.
- The students will use fine motor skills to produce works of art.

## Activities:

1. Introduce Piet Mondrian by reading his biography and showing some of his famous paintings. (Links on the biography page.)
2. Sing the P-A-I-N-T song to the tune of "Bingo". Display the letters P-A-I-N-T and sing the song. After singing the first verse, cover up the letter P with a picture of the paint brush. Sing the second verse as "brush, A-I-N-T".
3. Sort items into 2 categories: things with straight lines and things that do not have straight lines.
4. Follow the steps to create a Piet Mondrian inspired lines & squares drawing.

**Piet Mondrian** Modern Painting

**Biography** March 7, 1872  
Feb. 1, 1941

Piet Mondrian was born in the Netherlands in 1872. He lived with his mom, dad, three brothers and a sister. From an early age, Piet was exposed to art as both his father and uncle were artists. He knew early on that he too, wanted to be an artist.

After studying at a well-respected art school in Amsterdam, Piet began painting mainly abstract landscapes. As his career went on, his paintings become more and more abstract until he formed into the modern art he is known for today.

Mondrian's style of art uses many geometric shapes along with primary colors. Vertical and horizontal black lines frame red, blue, and yellow rectangles in many of his paintings. It is a style unique to him, and one that is easily recognizable.

**Famous Works:**

- "De Witte Kruis" - 1921
- "Composition III in Red, Blue, and Yellow" - 1920

**Fun Facts:**

- He earned a degree in education and was qualified to teach drawing.
- Mondrian created about 250 paintings in his lifetime.
- He founded the art movement, "De Stijl", which focused on basic shapes.

**Famous Quote:**

"Art is not made for anybody and it, at the same time, for everybody."

Scan for more information



**Literacy Extension:**  
Read "The Museum" by Susan Verde.

**Lines & Squares** Day 4  
Project

**Step 1:** Gather the materials:  
• 8" x 10" canvas or poster board  
• White poster or white acetate  
• Kwik Sticks (or paint or chalk)  
• Black electrical tape

**Step 2:** Place electrical tape on canvas in horizontal and vertical lines. Allow students to attach where they want to place the lines.

**Step 3:** Model how to paint rectangles and squares. Remind students to leave some white space like Mondrian did.

**Step 4:** Provide time for students to create their own Piet Mondrian inspired artwork.

\*Encourage students to sign each piece. Name the artist. Hang the completed pieces around the room in a gallery-like format.

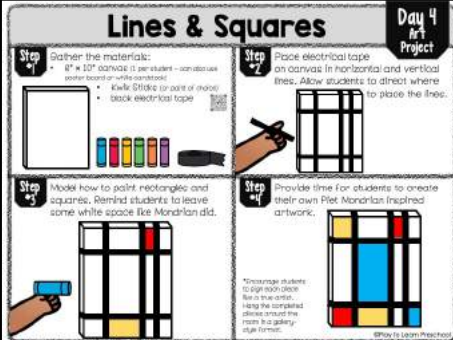

**P-A-I-N-T**

I can  
You  
I make b  
P-  
P-  
P-  
I make be



# Piet Mondrian

Modern  
Painting

## Biography

March 7, 1872

Feb. 1, 1944

Piet Mondrian was born in the Netherlands in 1872. He lived with his mom, dad, three brothers and a sister. From an early age, Piet was exposed to art as both his father and uncle were artists. He knew early on that he too, wanted to be an artist.

After studying at a well-respected art school in Amsterdam, Piet began painting mainly abstract landscapes. As his career went on, his paintings became more and more abstract until it formed into the modern art he is known for today.

Mondrian's style of art uses many geometric shapes along with primary colors. Vertical and horizontal black lines frame red, blue, and yellow rectangles in many of his paintings. It is a style unique to him, and one that is easily recognizable.

## Famous Works:

- [Tableau I](#) - 1921
- [Composition II in Red, Blue, and Yellow](#) - 1930

## Fun Facts:

- He earned a degree in education and was qualified to teach drawing.
- Mondrian created about 250 paintings in his lifetime.
- Co-founded the art movement, "De Stijl", which focused on basic shapes.

## Famous Quote:

"Art is not made for anybody and is, at the same time, for everybody."

Scan for more information

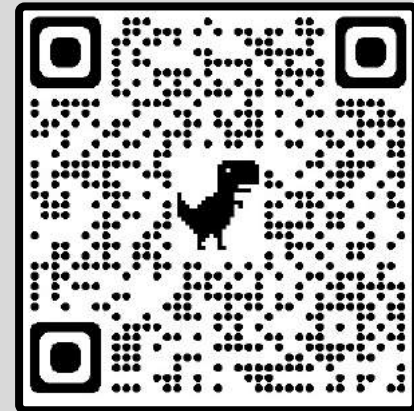

[https://kids.kiddle.co/Piet\\_Mondrian](https://kids.kiddle.co/Piet_Mondrian)

# P-A-I-N-T

To the tune of "Bingo"

I am an artist  
Yes, I am.

I make beautiful paintings.

**P-A-I-N-T**  
**P-A-I-N-T**  
**P-A-I-N-T**

I make beautiful paintings.





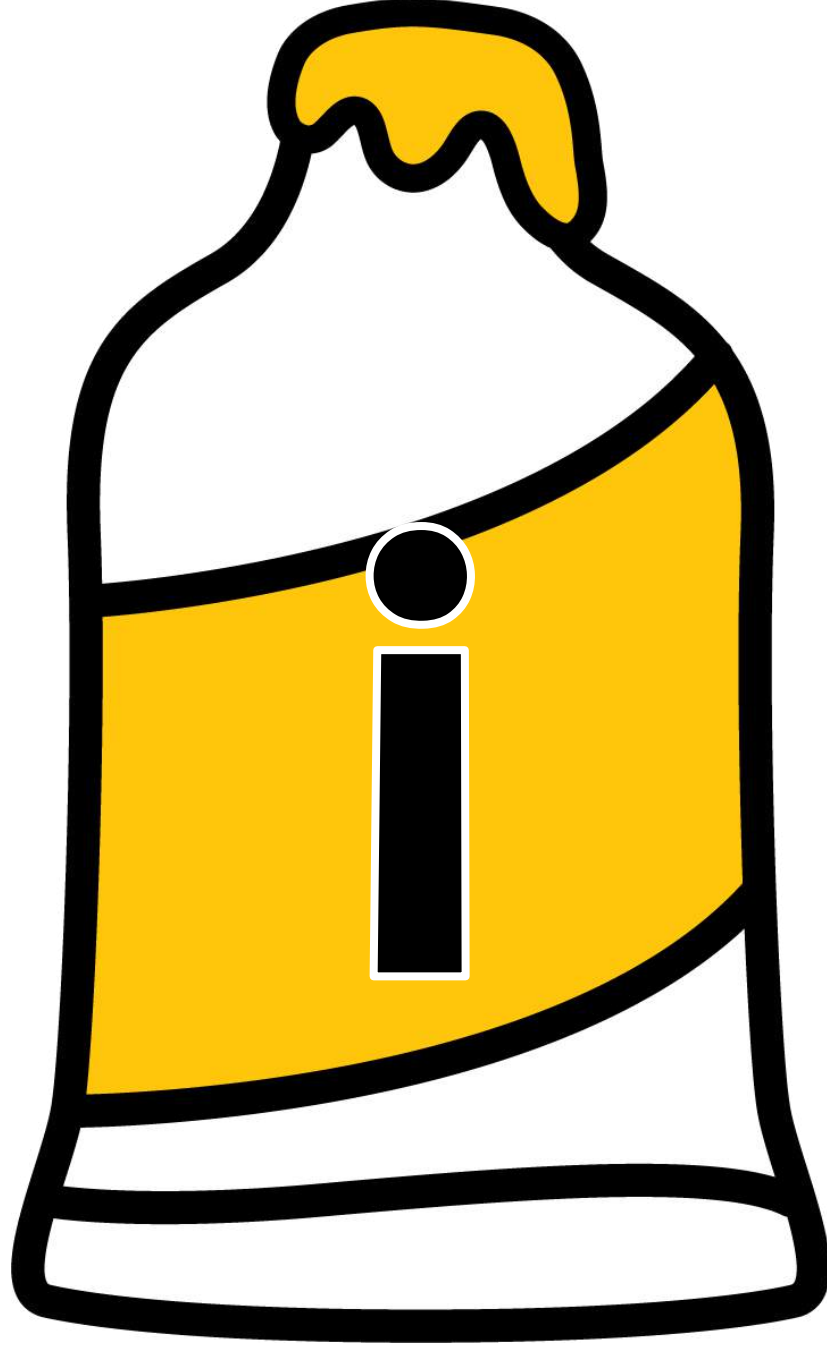

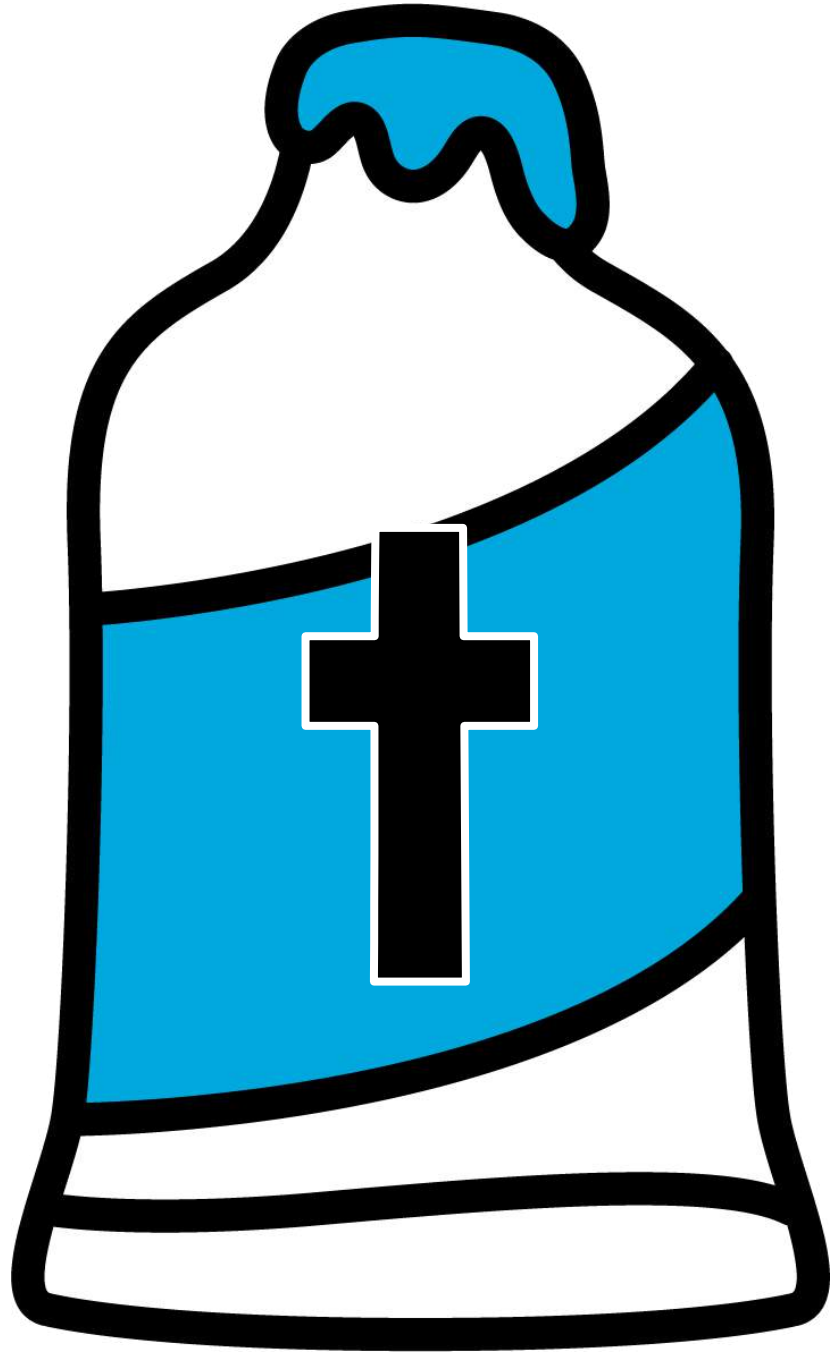





These things

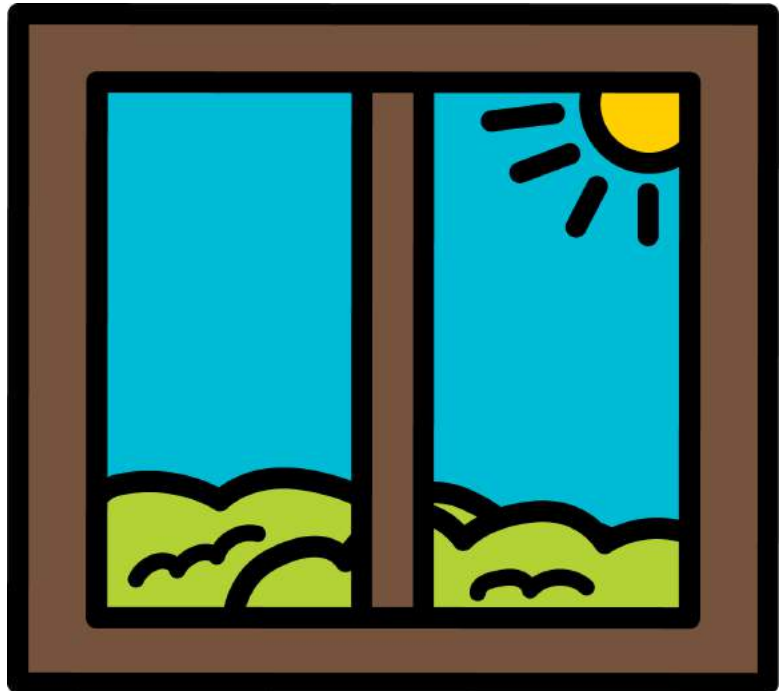

have  
**straight lines.**

These things

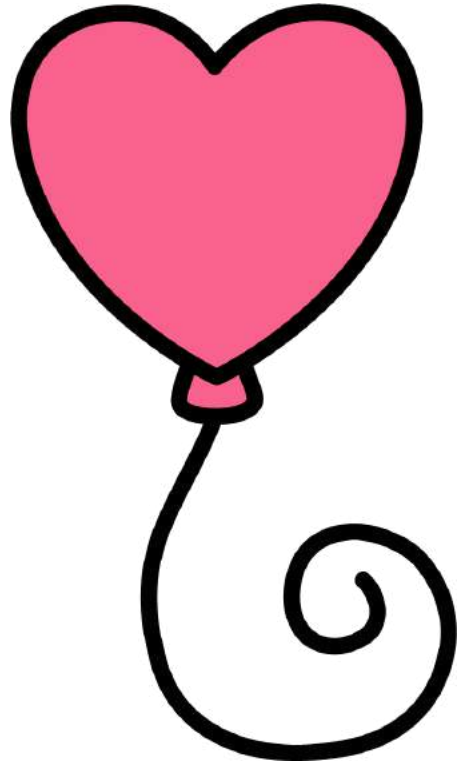

do **NOT** have  
**straight lines.**

Straight Sort

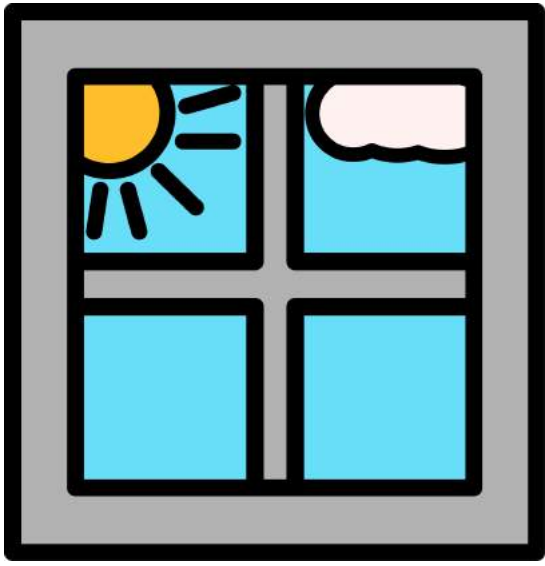

window

Straight Sort

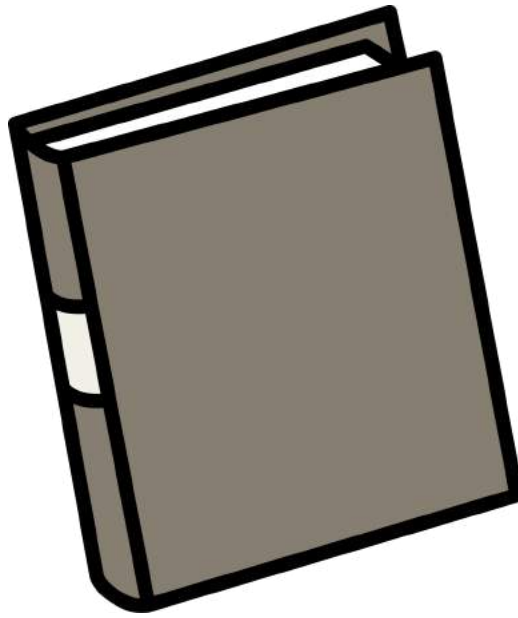

book

Straight Sort

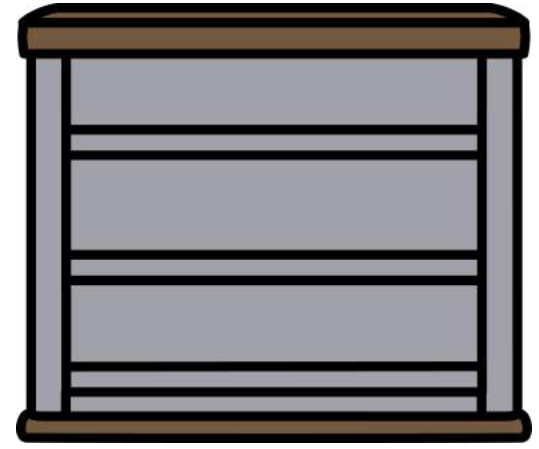

shelf

Straight Sort

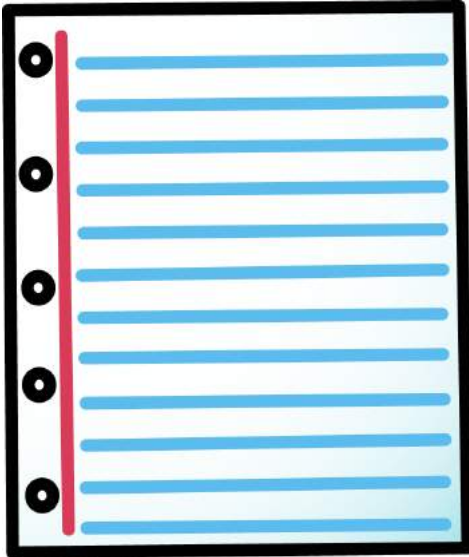

paper

Straight Sort

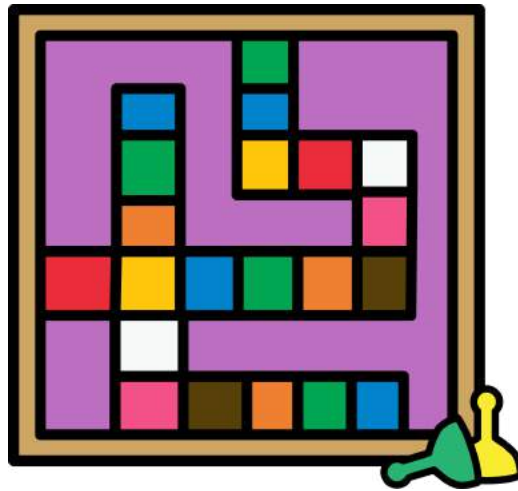

game board

Straight Sort

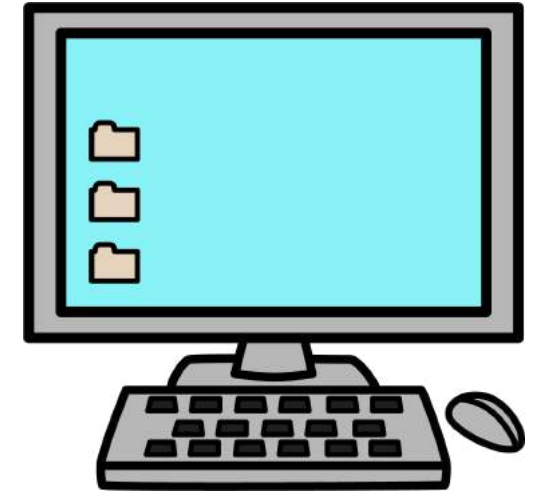

computer

Straight Sort

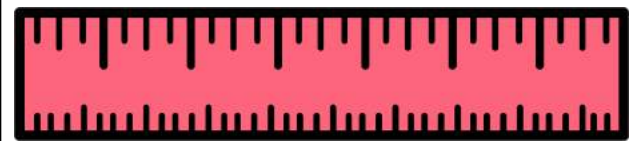

ruler

Straight Sort



house

Straight Sort

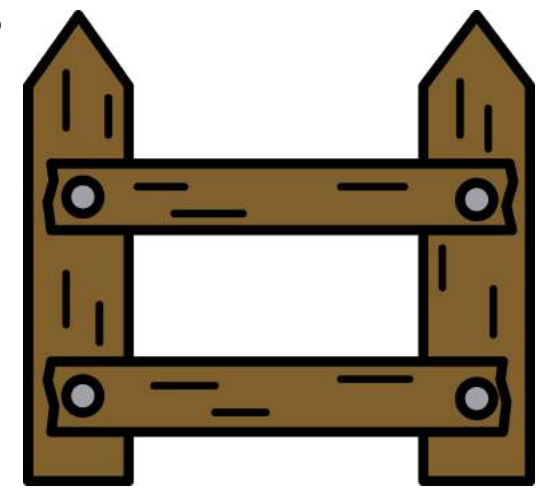

fence

Straight Sort



balloon

Straight Sort

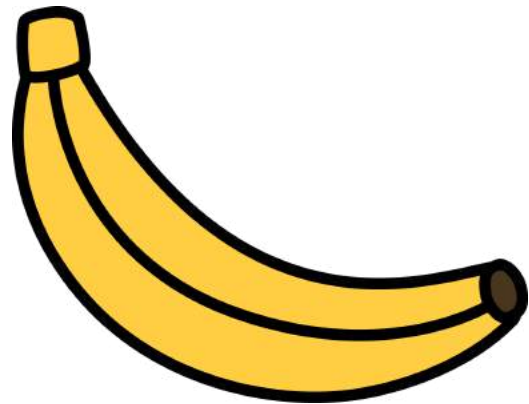

banana

Straight Sort



rainbow

Straight Sort



ice cream

Straight Sort

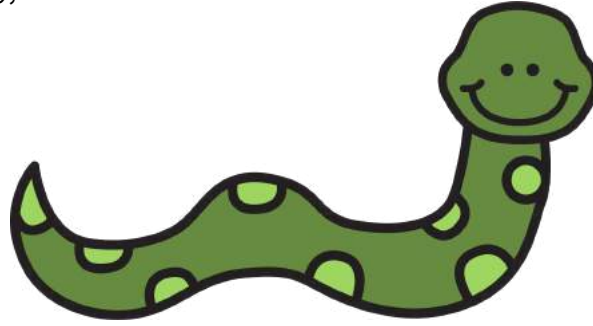

snake

Straight Sort



cookie

Straight Sort

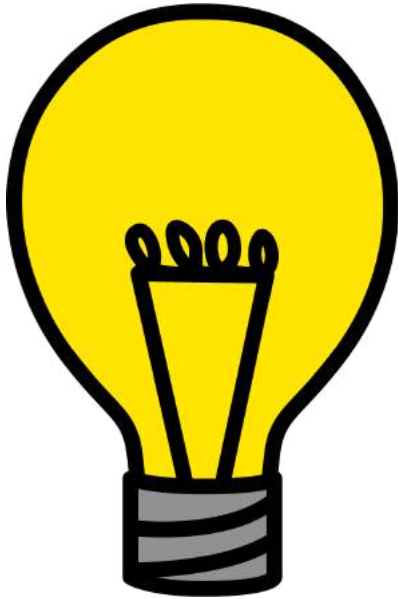

light bulb

Straight Sort



donut

Straight Sort



grass

# Lines & Squares

Day 4  
Art  
Project

Step  
#1

Gather the materials:

- 8" x 10" canvas (1 per student – can also use poster board or white cardstock)
- Kwik Stix (or paint of choice)
- black electrical tape

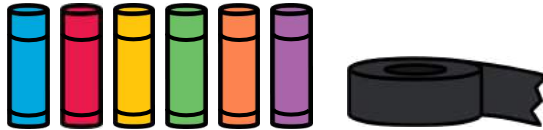
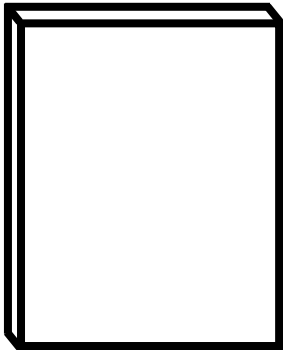

Step  
#2

Place electrical tape on a canvas in horizontal and vertical lines.

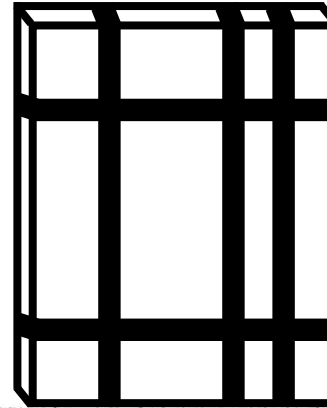
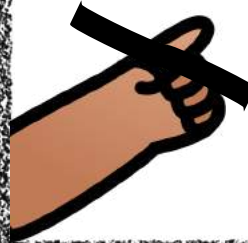

Step  
#3

Model how to paint rectangles and squares. Remind students to leave some white space like Mondrian did.

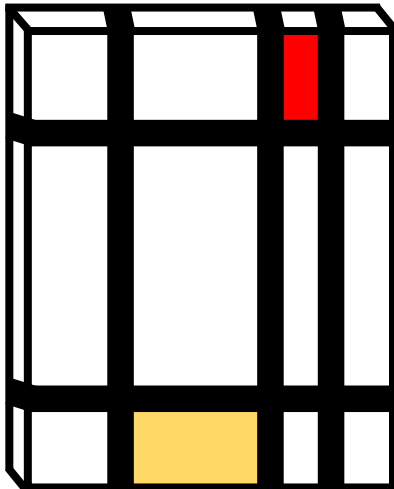

Step  
#4

Provide time for students to create their own Piet Mondrian inspired artwork.

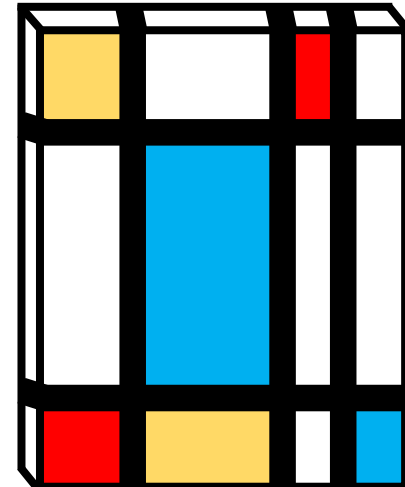

\*Encourage students to sign each piece like a true artist. Hang the completed pieces around the room in a gallery-style format.

# Wassily Kandinsky

Va-suh-lee Kan-din-skee

Day 5  
lesson  
plans

Sometimes referred to as the father of abstract art in the 20<sup>th</sup> century, Wassily Kandinsky created unique pieces of art that are still popular today.

## Objectives:

- The students will play with words, sounds, and rhymes.
- The students will demonstrate an understanding of print concepts.
- The students will use fine motor skills to produce works of art.

## Activities:

1. Introduce Wassily Kandinsky by reading his biography and showing some of his famous paintings. (Links on the biography page.)
2. Sing the "Shapes" song. As the class sings, use your finger to trace the shapes in the air.
3. Read the poem "I See." Add each of the sentences to a pocket chart. Use the picture cards to help emergent readers remember each line.
4. Follow the steps to create a Wassily Kandinsky inspired concentric circles painting.

### Wassily Kandinsky

**Biography** Dec. 16, 1866  
Dec. 13, 1911

Wassily Kandinsky was born in Russia. In 1886, As a child he was fascinated by colors and loved being in nature. He also loved music, and learned to play the cello and piano.

After finishing high school, Wassily went to college to study law. He taught law and economics until he was 30 when he decided he wanted to go back to school and become an artist. He studied in Munich, Germany and initially painted landscapes like many of the other artists at the time.

In time, Kandinsky began to think that his paintings didn't need to look realistic and moved towards using shapes and colors as his focus. This new form of art was called "abstract art", an art form that is still popular today.

**Famous Works:**

- *Improvisation No. 27* - 1912
- *Composition 8* - 1926
- *Yellow-Red* - 1928

**Fun Facts:**

- One of his great-grandmothers was a Mongolian princess.
- It is believed that he may have had synesthesia - a condition where he could see colors when listening to music.

**Famous Quote:**  
"Everything starts with a dot."

**Scan for more information:**



©Play to Learn Preschool

**Literacy Extension:**  
Read "The Dot"  
by Peter H.  
Reynolds.

### Concentric Circles

Day 5  
Art  
Project

**Step 1:** Cut drawing paper into an 8" x 8" square. Fold paper both vertically and horizontally to form four equal squares.

**Step 2:** Gather paint or markers. For students to use, Kwik Sticks are a fantastic option as they dry very quickly.

**Step 3:** Model how to complete one square at a time. Draw a circle in the center of the square. Then, using a different color, make another circle around the first circle. Continue for up to 4 colors.

**Step 4:** Provide time for students to create their own Kandinsky inspired artwork.

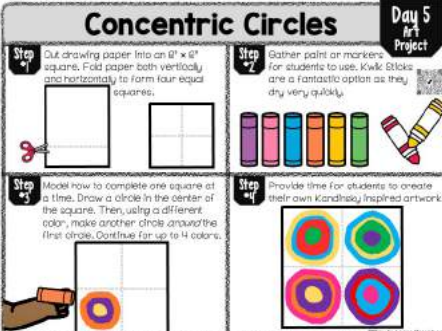

©Play to Learn Preschool

### Shapes

To the Tune of "Do You Know the Muffin Man"

Do you know what  
Shape this is,  
Shape this is,  
Shape this is?  
Do you know what  
Shape

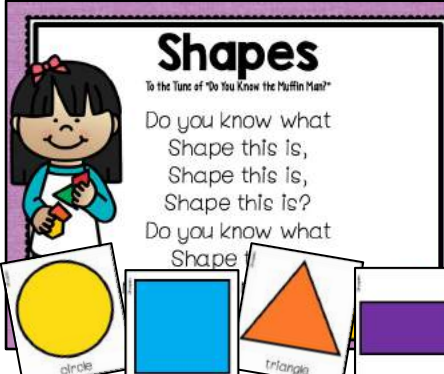



©Play to Learn Preschool

### I See!

I see a blue circle. 

I see a yellow circle. 

I see a pink circle. 

I see a purple circle. 

I see a green circle. 

I see a red circle. 

I see a happy artist. 

©Play to Learn Preschool

# Wassily Kandinsky

Abstract  
Painting

## Biography

Dec. 16, 1866

Dec. 13, 1944

Wassily Kandinsky was born in Russia in 1866. As a child he was fascinated by colors and loved being in nature. He also loved music, and learned to play the cello and piano.

After finishing high school, Wassily went to college to study law. He taught law and economics until he was 30 when he decided he wanted to go back to school and become an artist. He studied in Munich, Germany and initially painted landscapes like many of the other artists at the time.

In time, Kandinsky began to think that his paintings didn't need to look realistic and moved towards using shapes and colors as his focus. This new form of art was called "abstract art", an art form that is still popular today.

## Famous Works:

- [Concentric Circles](#)– 1913
- [Several Circles](#) - 1926
- [Inner Alliance](#) – 1929

## Fun Facts:

- One of his great-grandmothers was a Mongolian princess.
- It is believed that he may have had synesthesia – a condition where he could *see* colors when listening to music.

## Famous Quote:

“Everything starts with a dot.”

Scan for more information



<https://kids.kiddle.co/Kandinsky>

# Shapes

To the Tune of "Do You Know the Muffin Man?"

Do you know what  
Shape this is,  
Shape this is,  
Shape this is?

Do you know what  
Shape this is

And can you make it too?

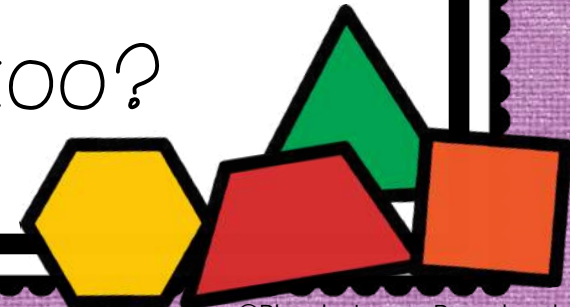
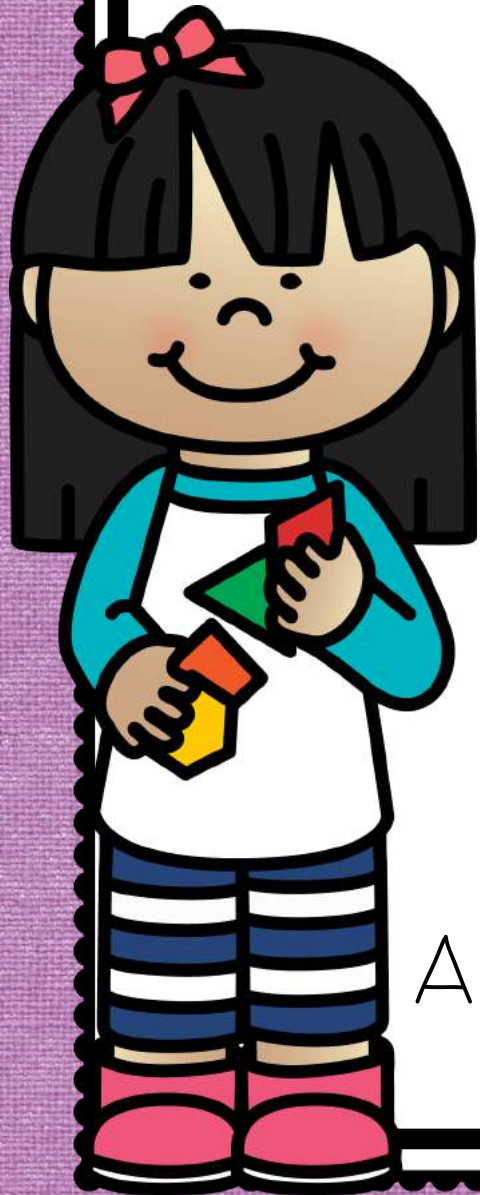

Shapes

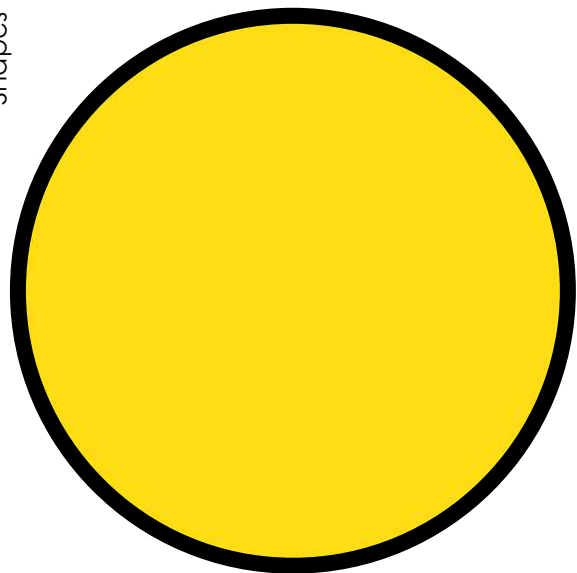

circle

Shapes

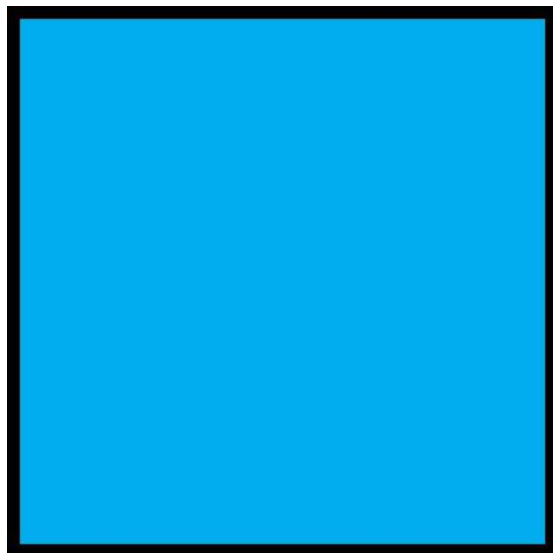

square

Shapes

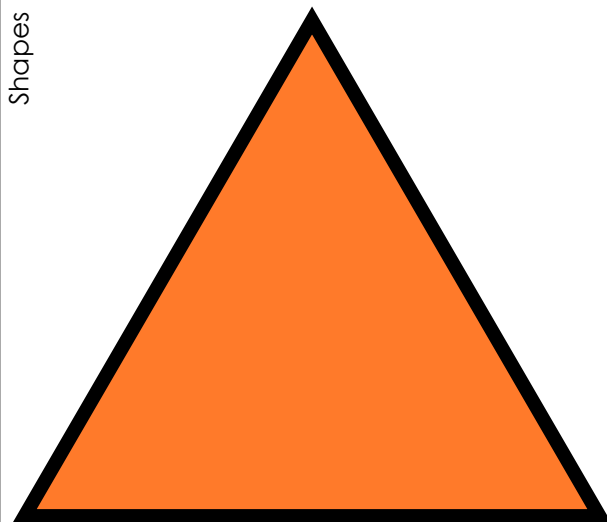

triangle

Shapes



rectangle

Shapes

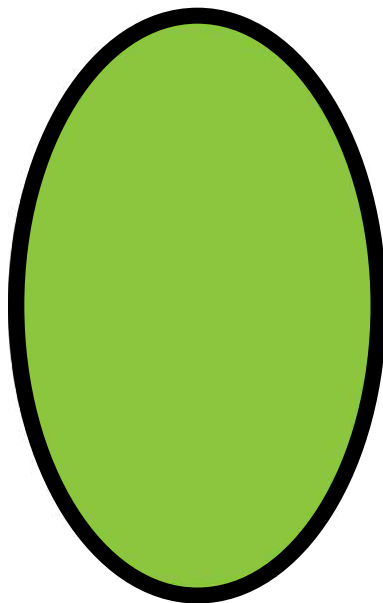

oval

Shapes



trapezoid

# I See!

I see a blue circle.

I see a yellow circle.

I see a pink circle.

I see a purple circle.

I see a green circle.

I see a red circle.

I see a happy artist!



I see a

blue circle.

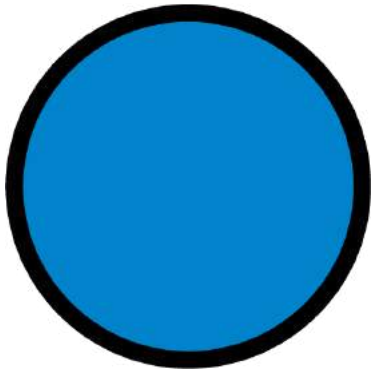

blue

I see a

yellow circle.

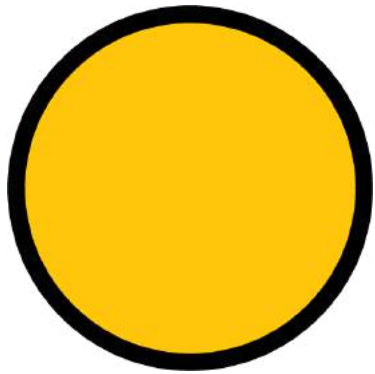

yellow

I see a

pink circle.

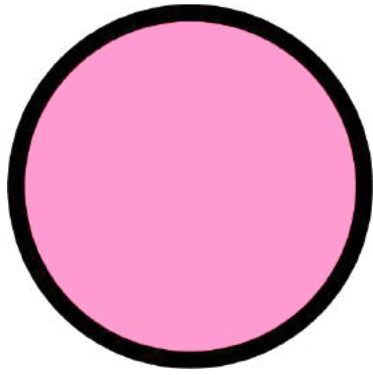

pink

I see a

purple circle.

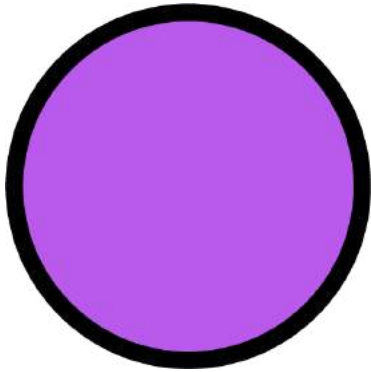

purple

I see a

green circle.

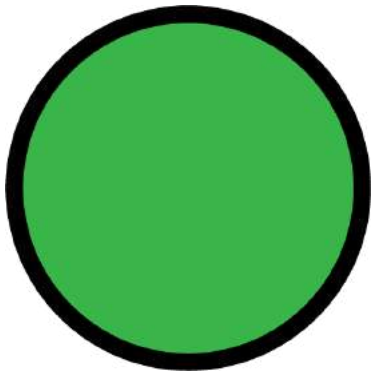

green

I see a

red circle.

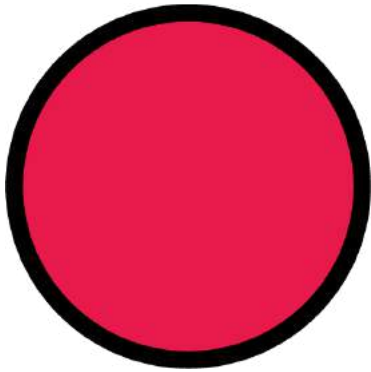

red

I see a

happy artist.



# Concentric Circles

Day 5  
Art  
Project

Step  
#1

Cut drawing paper into an 8" x 8" square. Fold paper both vertically and horizontally to form four equal squares.

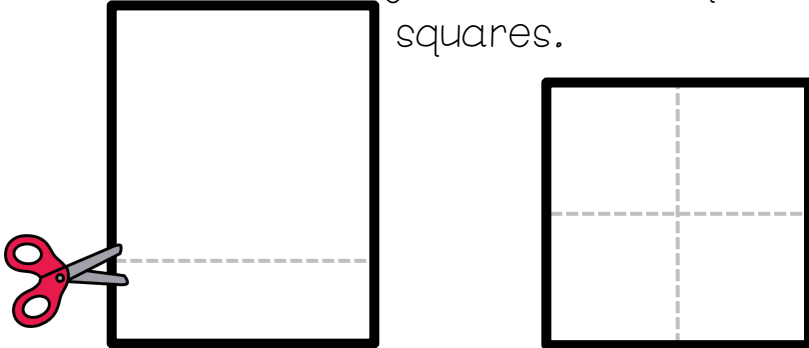

Step  
#2

Gather paint or markers for students to use. Kwik Stix are a fantastic option as they dry very quickly.

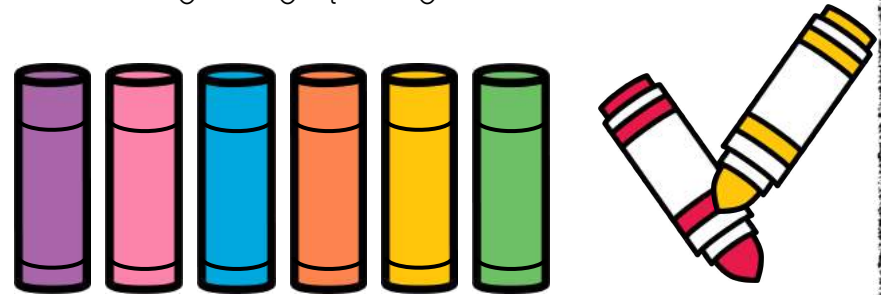

Step  
#3

Model how to complete one square at a time. Draw a circle in the center of the square. Then, using a different color, make another circle *around* the first circle. Continue for up to 4 colors.

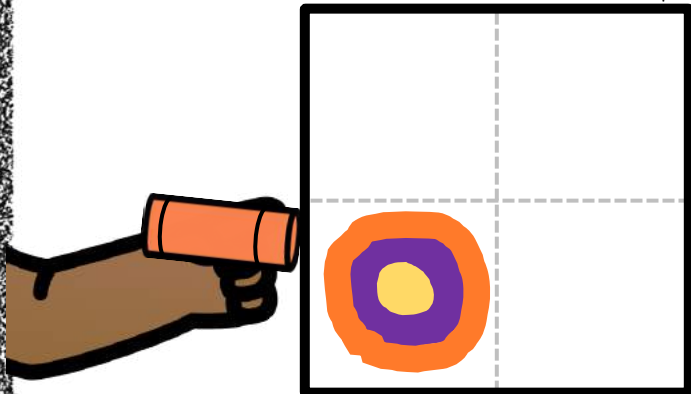

Step  
#4

Provide time for students to create their own Kandinsky inspired artwork.

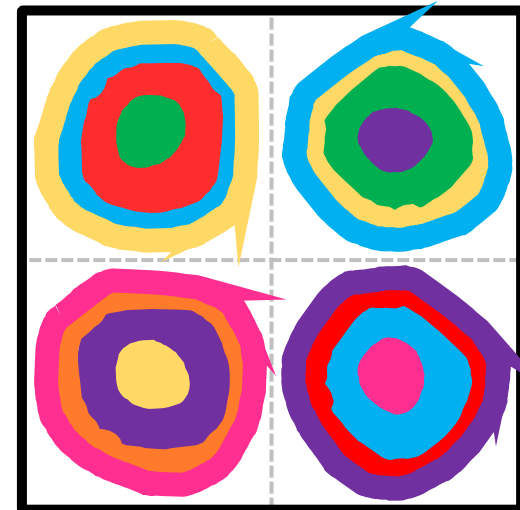

# Yayoi Kusama

Yaa-yoy Koo-saa-muh

Day 6  
lesson  
plans

Yayoi Kusama views the world in a series of colorful dots. These dots form the foundation of her artwork.

## Objectives:

- The students will notice and extend simple patterns.
- The students will play with words, sounds, and rhymes.
- The students will use fine motor skills to produce works of art.

## Activities:

1. Introduce Yayoi Kusama by reading her biography and showing some of her famous paintings. (Links on the biography page.)
2. Make an AB and AAB pattern with the art supply cards. Ask students what comes next in the pattern.
3. Sing the "Ten Little Polka Dots" song. Print out the tens-frame and counters, then practice counting from 1-10 and 10-1.
4. Follow the steps to create a Yayoi Kusama inspired polka dot work of art.

**Yayoi Kusama** Contemporary Art

**Biography** March 22, 1921

Yayoi Kusama was born in Japan in 1921. She always enjoyed paintings and often saw the world as a mix of colorful dots. She attended the Kyoto City Specialist School of Arts for only one year, but continued to create and paint despite her lack of formal training.

Kusama moved from Japan to the New York City in the United States when she was 26 years old. While she continued to paint, she explored other aspects of art such as public performing, movie creation, public installations, fashion design, music, and sculptures.

She returned to Japan in 1973 but continues to show her art all around the world. She has won many prizes for her art and even has a museum dedicated to her work in Tokyo, Japan!

**Famous Works:**

- *Infinity - 1965*
- *Yellow Rooms - 1991*
- *Infinity Room Installation - 2015*

**Fun Facts:**

- In 2020, she created a balloon for the Macy's Thanksgiving Day parade.
- Her most expensive painting sold for over seven million dollars!

**Famous Quote:**  
"I have a flood of ideas in my mind. I just follow my vision."

Scan for more information



©Play to Learn Preschool

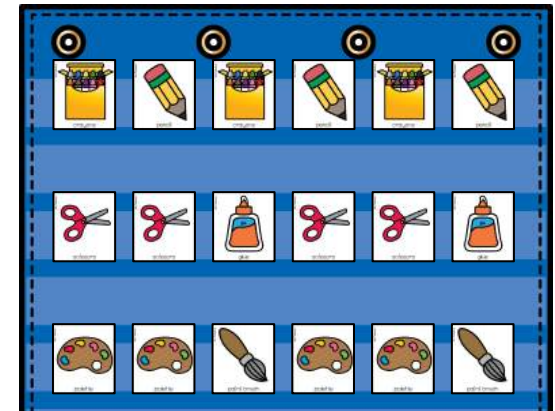

**Literacy Extension:**  
Read "Elmer" by David McKee.

**Polka-Dot Elephants** Day 6 Art Project

**Step 1:** Print copies of the elephant outline on bright white paper.

**Step 2:** Gather the materials: polka dot stickers, washable markers (1 for each student).

**Step 3:** Model how to remove stickers from the page and place them around the elephant. Remind students that there is no "right" way of where to place the stickers. They are the artist!

**Step 4:** Provide time for students to create their own Kusama inspired artwork.

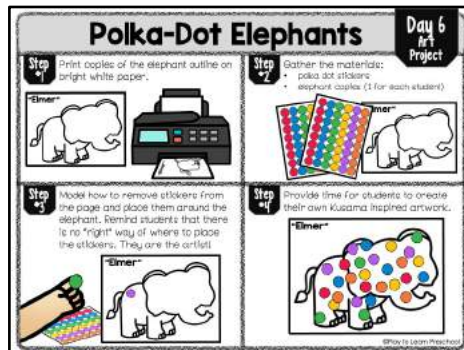

©Play to Learn Preschool

**10 Little Polka Dots**



Counting Song









1 little, 2 little, 3 little  
Polka Dots!



4 little, 5 little, 6 little  
Polka Dots!

7 little, 8 little, 9 little  
Polka Dots!

10 little polka dots  
In a row!

## Biography March 22, 1929

Yayoi Kusama was born in Japan in 1929. She always enjoyed paintings and often saw the world as a mix of colorful dots. She attended the Kyoto City Specialist School of Arts for only one year, but continued to create and paint despite her lack of formal training.

Kusama moved from Japan to the New York City in the United States when she was 28 years old. While she continued to paint, she explored other aspects of art such as public performing, movie creation, public installations, fashion design, music, and sculptures.

She returned to Japan in 1973 but continues to show her art all around the world. She has won many prizes for her art and even has a museum dedicated to her work in Tokyo, Japan!

### Famous Works:

- [Butterfly](#) – 1985
- [Yellow Pumpkin](#) - 1994
- [Infinity Room](#) Installation – 2015

### Fun Facts:

- In 2020, she created a balloon for the Macy's Thanksgiving Day parade.
- Her most expensive painting sold for over seven million dollars!

### Famous Quote:

"I have a flood of ideas in my mind. I just follow my vision."

Scan for more information

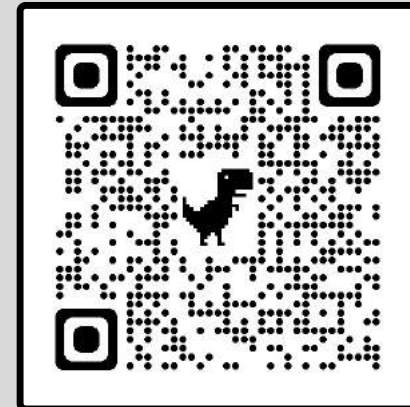

<https://www.tate.org.uk/kids/explore/who-is/who-yayoi-kusama>

Art Patterns

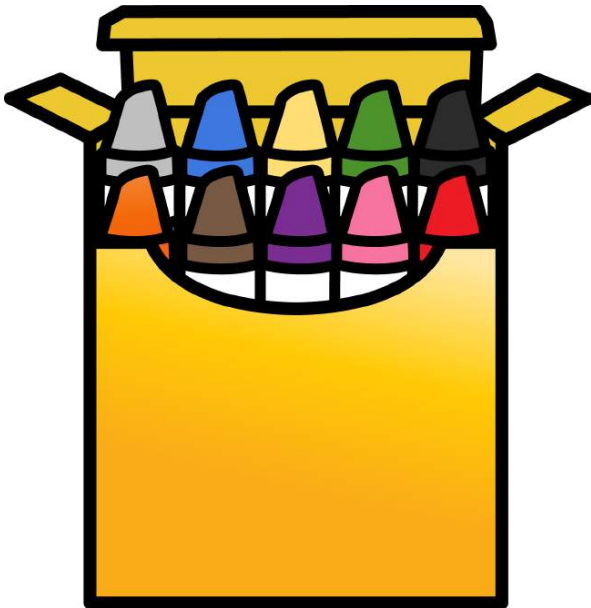

crayons

Art Patterns

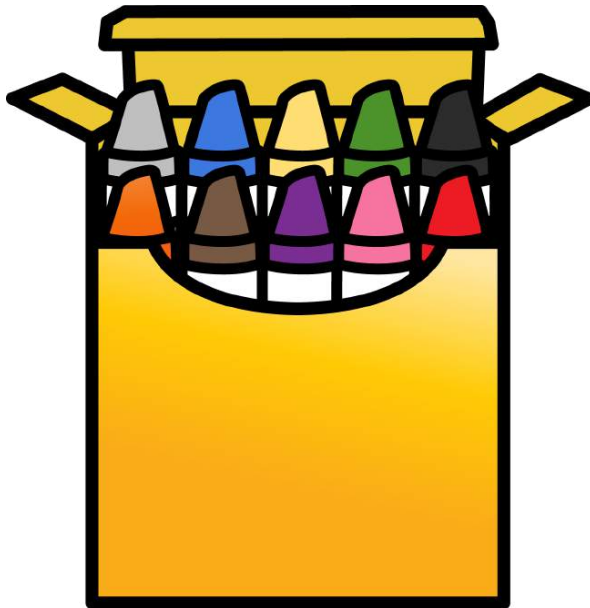

crayons

Art Patterns

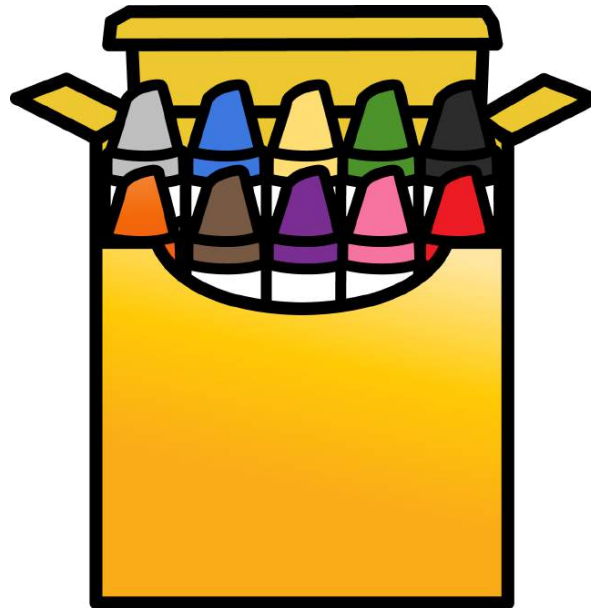

crayons

Art Patterns

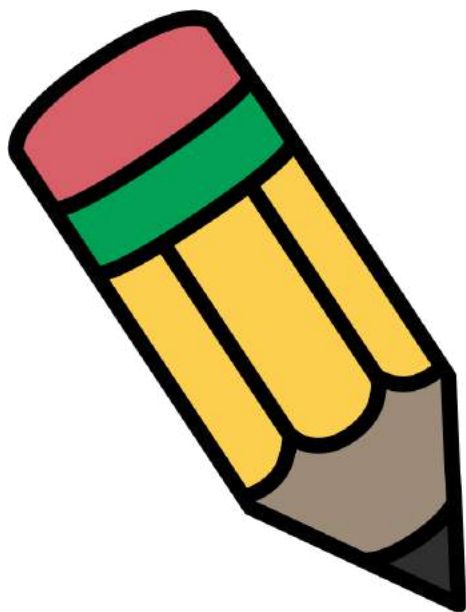

pencil

Art Patterns

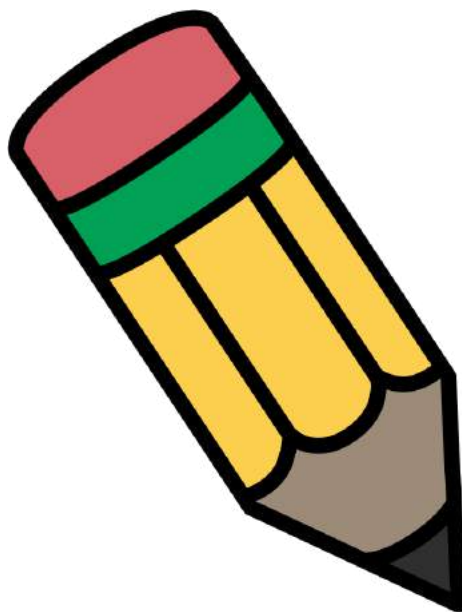

pencil

Art Patterns

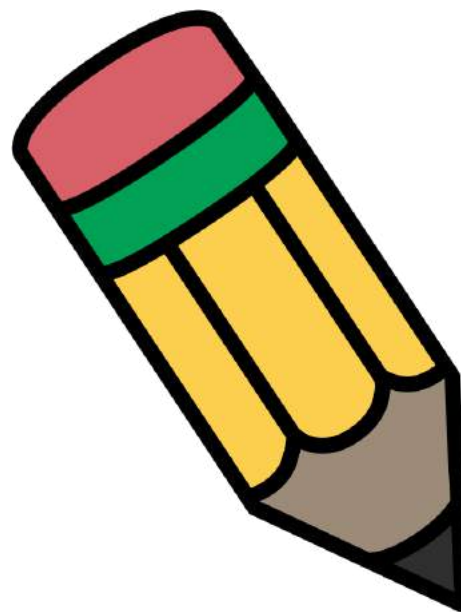

pencil

Art Patterns

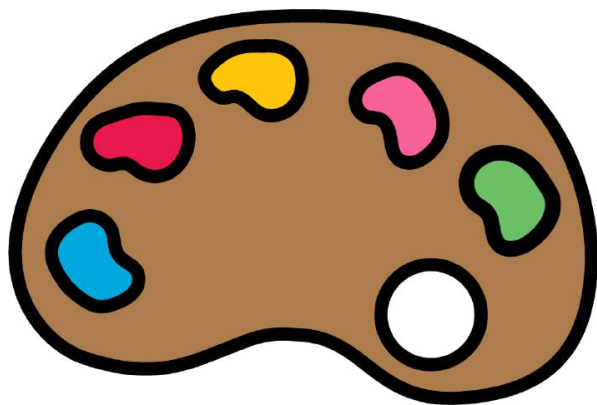

palette

Art Patterns

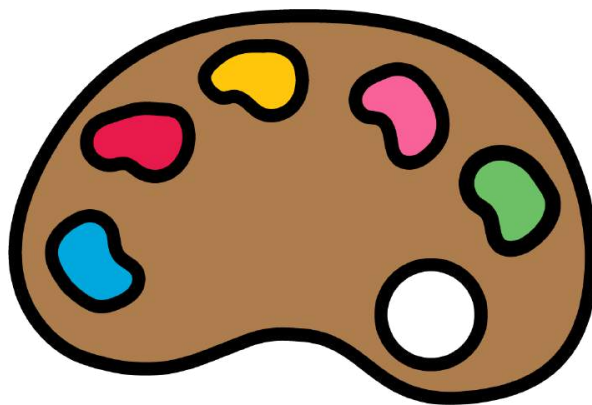

palette

Art Patterns



palette

Art Patterns

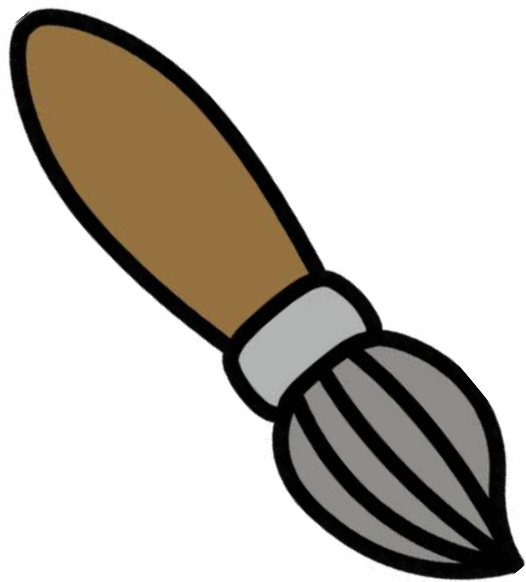

paint brush

Art Patterns

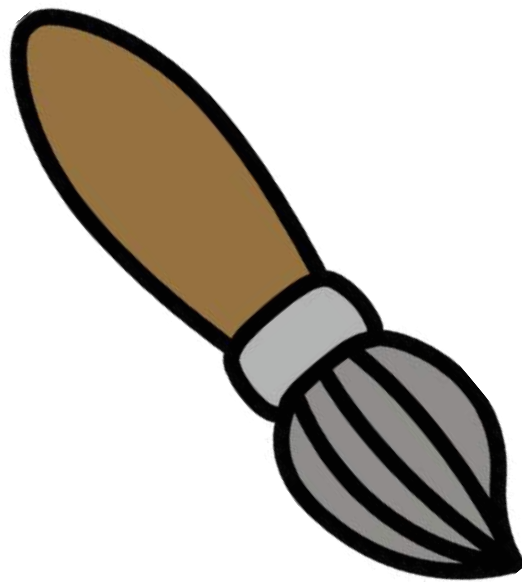

paint brush

Art Patterns

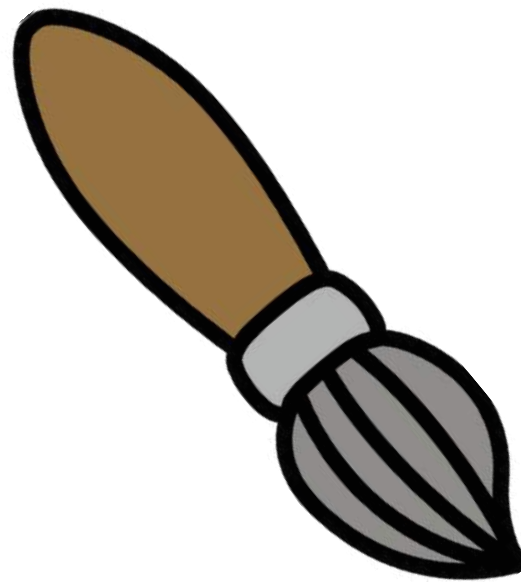

paint brush

Art Patterns

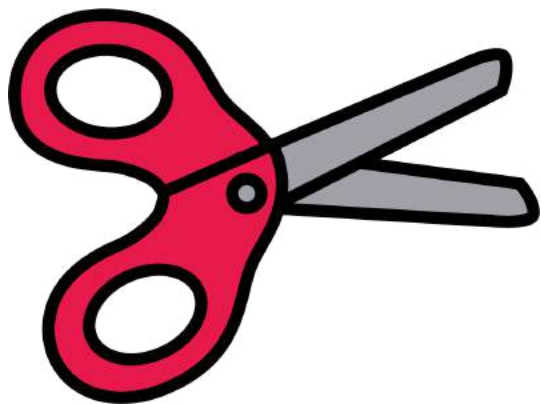

scissors

Art Patterns

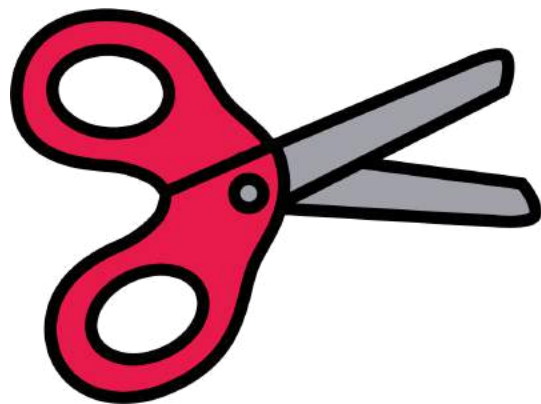

scissors

Art Patterns



scissors

Art Patterns



glue

Art Patterns



glue

Art Patterns



glue

# 10 Little Polka Dots

Counting Song

1 little, 2 little, 3 little  
Polka Dots!

4 little, 5 little, 6 little  
Polka Dots!

7 little, 8 little, 9 little  
Polka Dots!

10 little polka dots  
In a row!

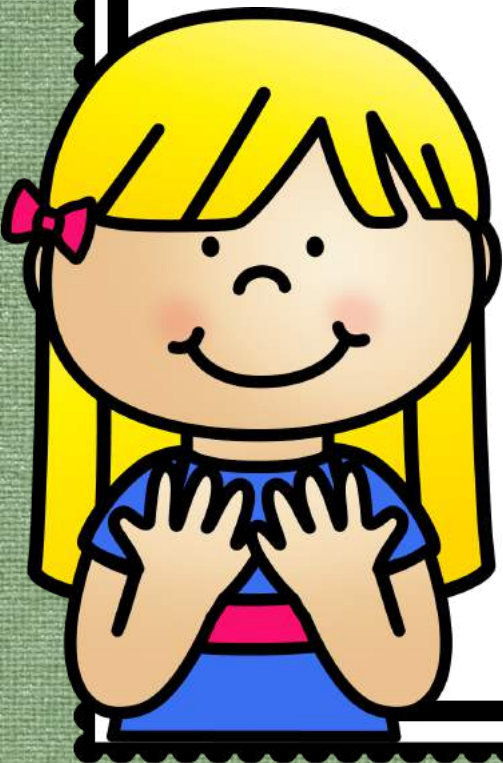
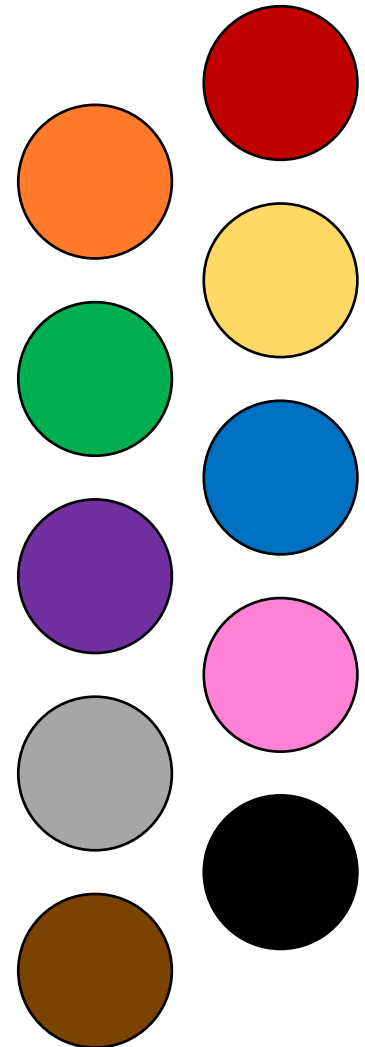

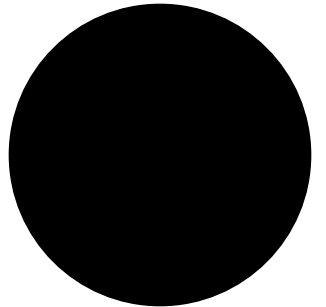
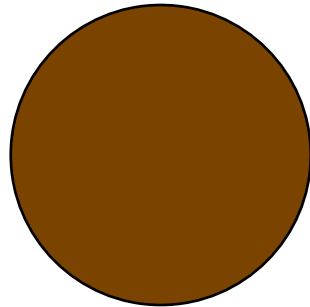
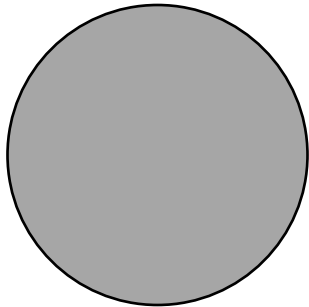
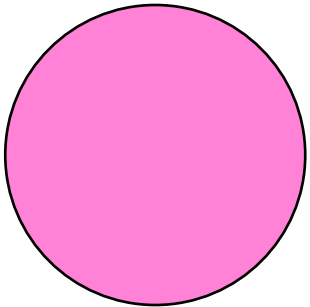
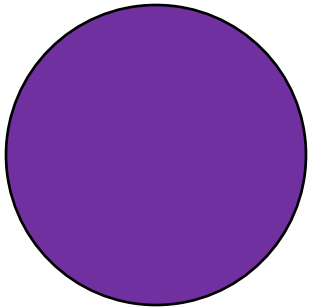
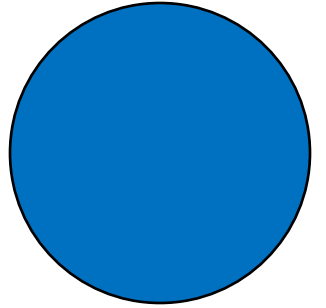
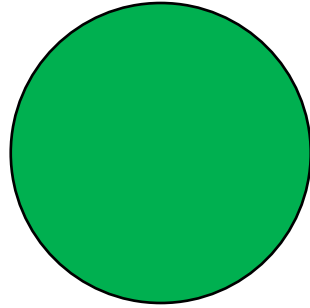
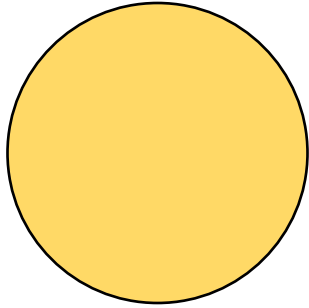
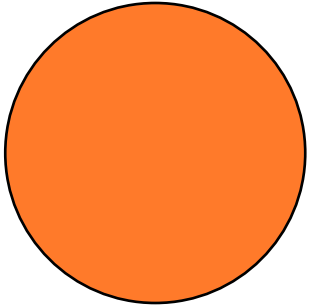
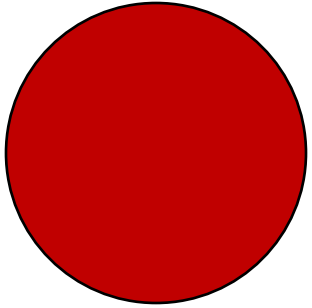



# Polka-Dot Elephants

Day 6  
Art  
Project

Step  
#1

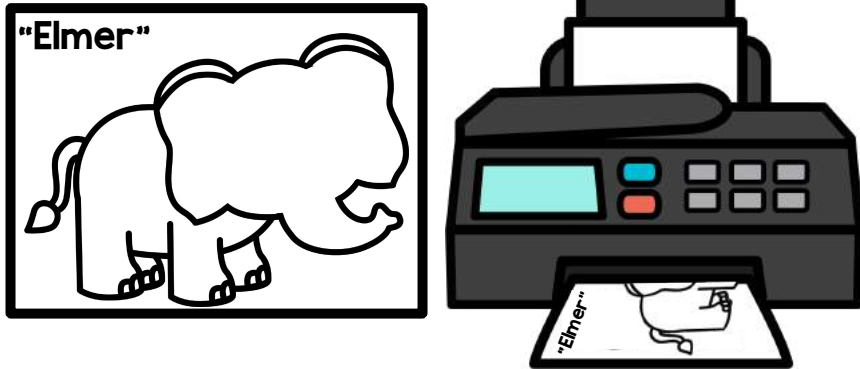
Print copies of the elephant outline on bright white paper.



Step  
#2

Gather the materials:

- polka dot stickers
- elephant copies (1 for each student)

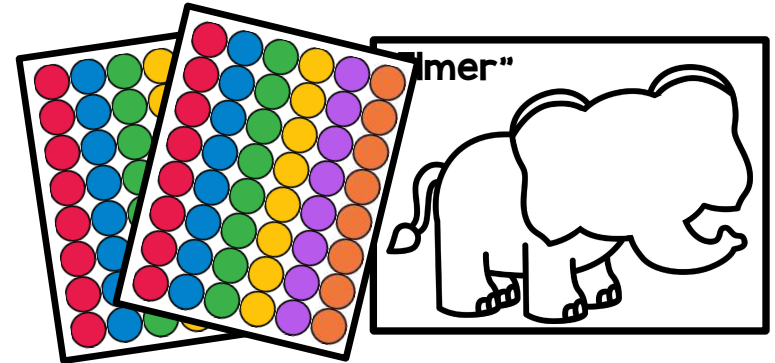

Step  
#3

Model how to remove stickers from the page and place them around the elephant. Remind students that there is no "right" way of where to place the stickers. They are the artist!

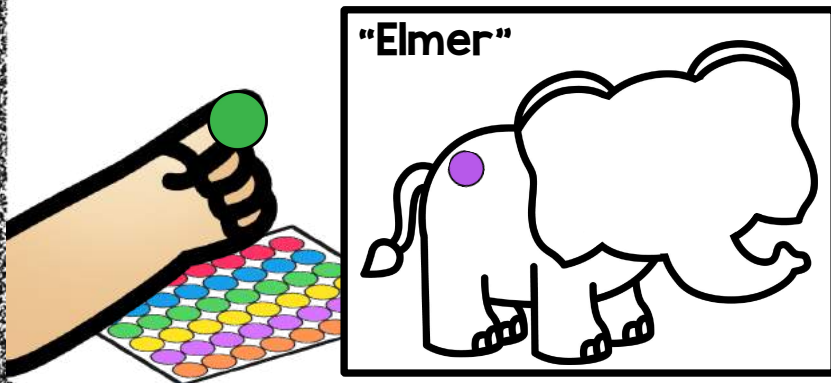

Step  
#4

Provide time for students to create their own Kusama inspired artwork.

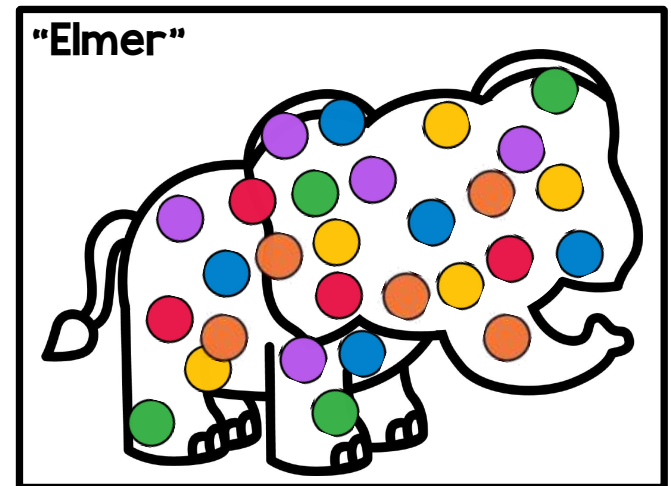

# “Elmer”

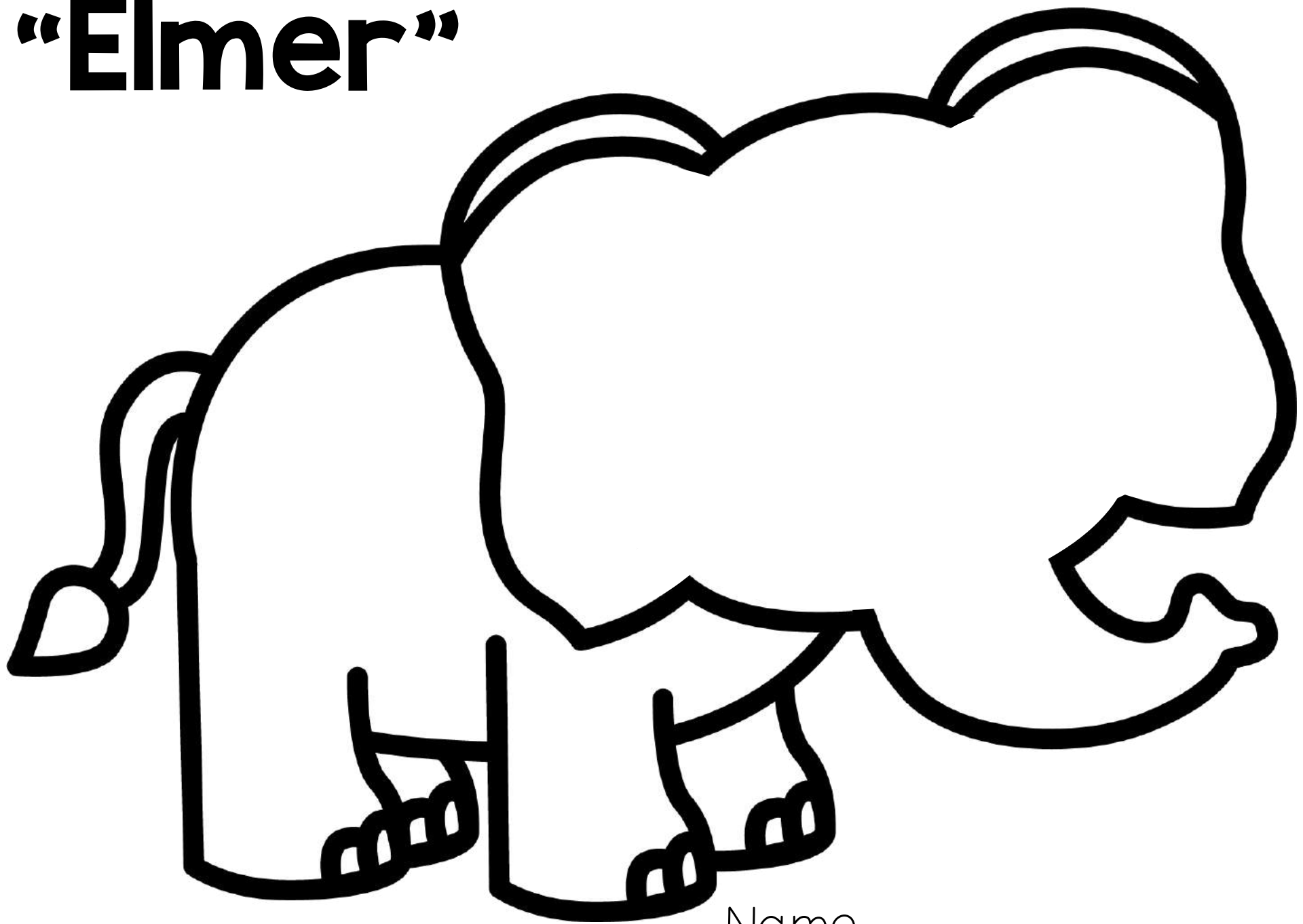

Name \_\_\_\_\_

# Vincent Van Gogh

Vin-sunt Van Go

Day 7  
Lesson  
Plans

With exhibits and collections housed all over the world, Vincent Van Gogh is one of the most recognized artists of all time.

## Objectives:

- The students will count sets to 5 and make combinations of items to create the set.
- The students will demonstrate an understanding of print concepts.
- The students will use fine motor skills to produce works of art.

## Activities:

1. Introduce Vincent Van Gogh by reading his biography and showing some of his famous paintings. (Links on the biography page.) Bring in real sunflowers for the students to explore, if possible.
2. Recite the “5 Pretty Sunflowers” counting poem.
3. Point out the different parts of a sunflower. Label the picture of the sunflower.
4. Follow the steps to create a Vincent Van Gogh inspired sunflower directed drawing.

**Vincent Van Gogh** Oil Painting

**Biography** March 30, 1853 - July 29, 1890

Vincent Van Gogh was born in the Netherlands in 1853. He lived with his parents, two brothers, and three sisters. His mother was an artist and his father was a minister. Although Vincent always enjoyed art, he didn't decide to do it for a living until he was 27 years old.

Over the years, Van Gogh's painting changed from using a lot of dark colors to bolder, brighter colors. He painted landscapes, still-life, a lot of people, and even did self-portraits. Sometimes, he would use so much paint that the art would take weeks to dry!

While Vincent Van Gogh is a well-known artist today, he was not famous during his lifetime. In fact, he only sold one painting while he was alive! Today, his paintings sell for a lot of money.

**Fun Facts:**

- Vincent Van Gogh loved selfies. He used a mirror to look at himself and painted over 20 self-portraits.
- There were four people named Vincent Van Gogh – the artist, his grandfather, his nephew, and an older brother.

**Famous Quote:**  
“A good picture is equivalent to a good deed.”

Scan for more information



**Famous Works:**

- *The Bedroom* – 1889
- *The Starry Night* – 1889
- *Sunflowers* – 1889

**Literacy Extension:**  
Read “Camille and the Sunflowers” by Laurence Anholt.

**Sunflower Directed Drawing** Day 7 Art Project

**Step 1:** Show pictures of sunflowers or bring in sunflowers for the class to explore. Point out the petals, stem, and leaves.

**Step 2:** Gather & distribute the materials:  
• white drawing paper  
• black markers  
• crayons or colored pencils

**Step 3:** Direct students in the drawing process:  
1. Draw a circle in the middle of the page with a black marker.  
2. Draw pretty petals around the circle with the marker.

**Step 4:** 3. Draw a stem and leaves below the flower petals.  
4. Color in the picture with crayons or colored pencils.

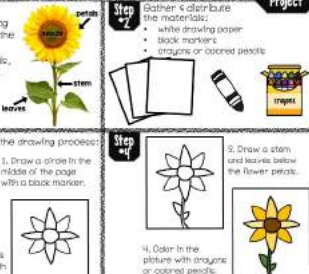

Name \_\_\_\_\_

**I can label the parts of a sunflower.**



petals

seeds

stem

leaves

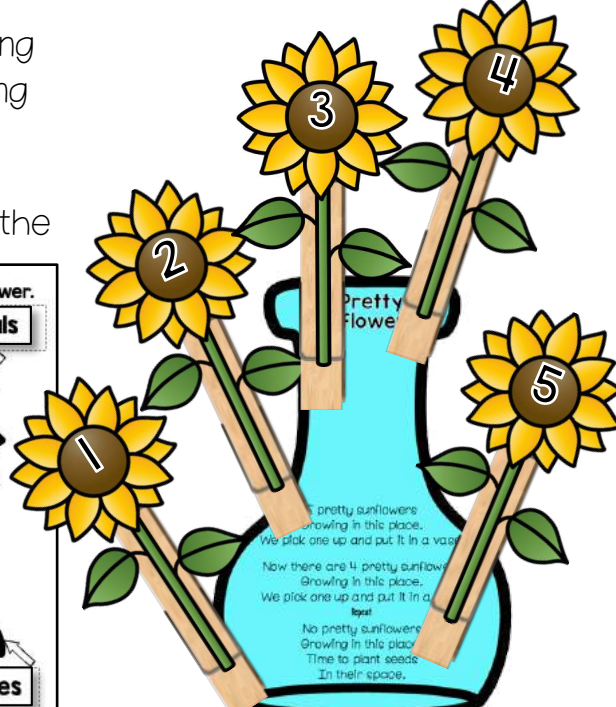

5 pretty sunflowers  
growing in this place.  
We pick one up and put it in a vase.

Now there are 4 pretty sunflowers  
growing in this place.  
We pick one up and put it in a vase.

Now there are 3 pretty sunflowers  
growing in this place.  
We pick one up and put it in a vase.

Now there are 2 pretty sunflowers  
growing in this place.  
We pick one up and put it in a vase.

Now there are 1 pretty sunflowers  
growing in this place.  
Time to plant seeds  
in their space.

# Vincent Van Gogh

Oil  
Painting

## Biography

March 30, 1853

July 29, 1890

Vincent Van Gogh was born in the Netherlands in 1853. He lived with his parents, two brothers, and three sisters. His mother was an artist and his father was a minister. Although Vincent always enjoyed art, he didn't decide to do it for a living until he was 27 years old.

Over the years, Van Gogh's painting changed from using a lot of dark colors to bolder, brighter colors. He painted landscapes, still-life, people, and even did self portraits. Sometimes, he would use so much paint that the art would take weeks to dry!

While Vincent Van Gogh is a well-known artist today, he was not famous during his lifetime. In fact, he only sold one painting while he was alive! Today, his paintings sell for *a lot* of money.

## Famous Works:

- [The leavesroom](#) – 1888
- [The Starry Night](#) – 1889
- [Sunflowers](#) - 1889

## Fun Facts:

- Vincent Van Gogh loved selfies. He used a mirror to look at himself and painted over 20 self-portraits.
- There were four people named 'Vincent Van Gogh' – the artist, his grandfather, his nephew, and an older brother.

## Famous Quote:

“A good picture is equivalent to a good deed.”

Scan for more information

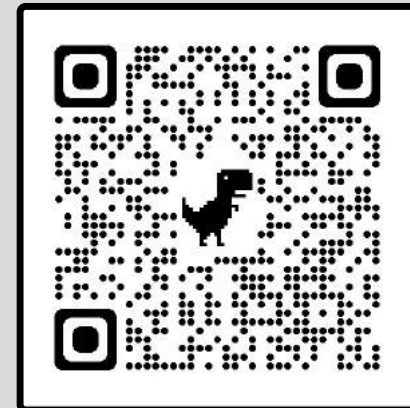

[https://kids.kiddle.co/  
Vincent\\_van\\_Gogh](https://kids.kiddle.co/Vincent_van_Gogh)

**I can label the parts of a sunflower.**

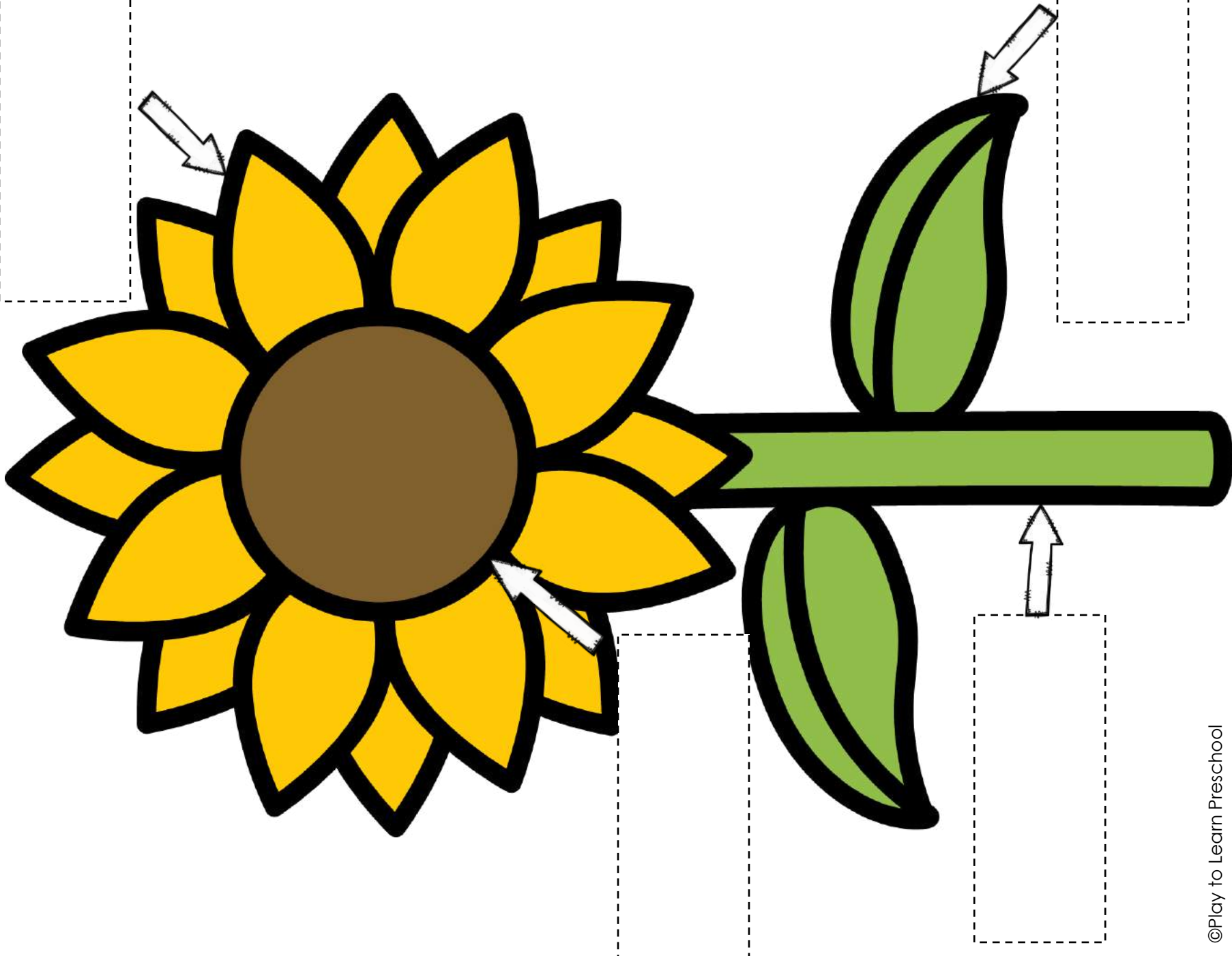

Name \_\_\_\_\_

**I can label the parts of a sunflower.**

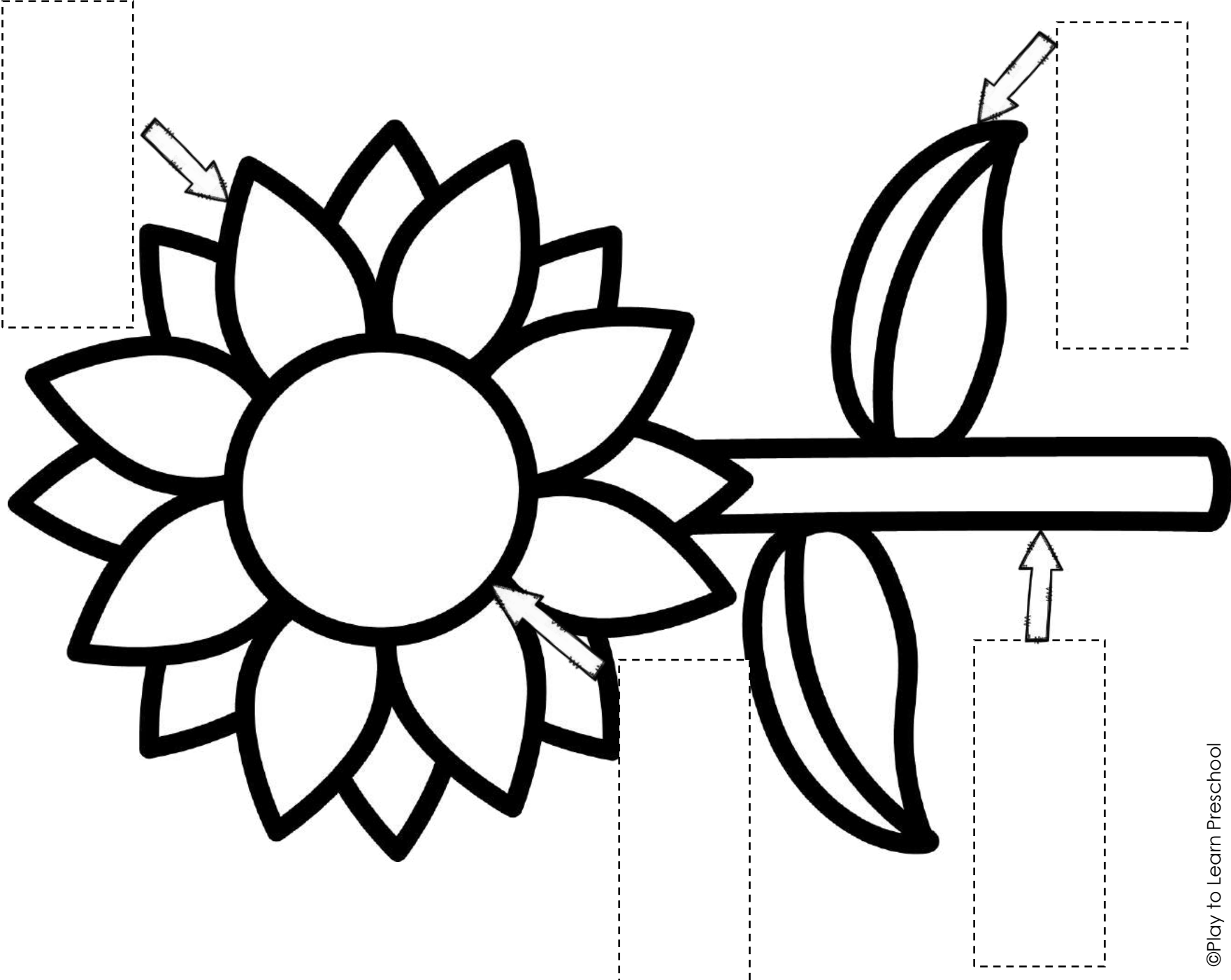

Use these cards to label the parts of a sunflower.

©Play to Learn Preschool

**petals**

**seeds**

**leaves**

**stem**

**petals**

**seeds**

**leaves**

**stem**

**petals**

**seeds**

**leaves**

**stem**

**petals**

**seeds**

**leaves**

**stem**

**petals**

**seeds**

**leaves**

**stem**

**petals**

**seeds**

**leaves**

**stem**

**petals**

**seeds**

**leaves**

**stem**

# 5 Pretty Sunflowers

## Chip Clip Poem

5 pretty sunflowers  
Growing in this place.  
We pick one up and put it in a vase.

Now there are 4 pretty sunflowers  
Growing in this place.  
We pick one up and put it in a vase

## Repeat

No pretty sunflowers  
Growing in this place.  
Time to plant seeds  
In their space.

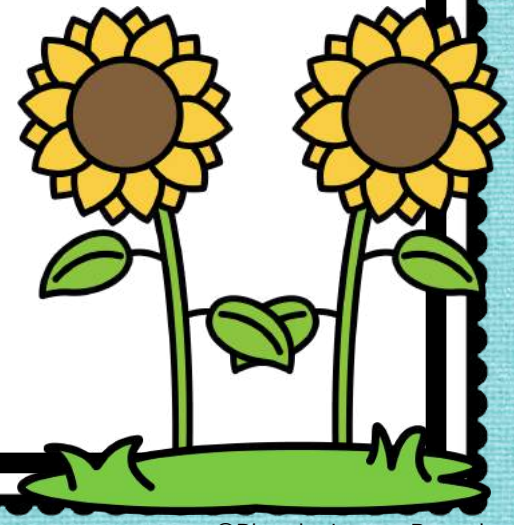
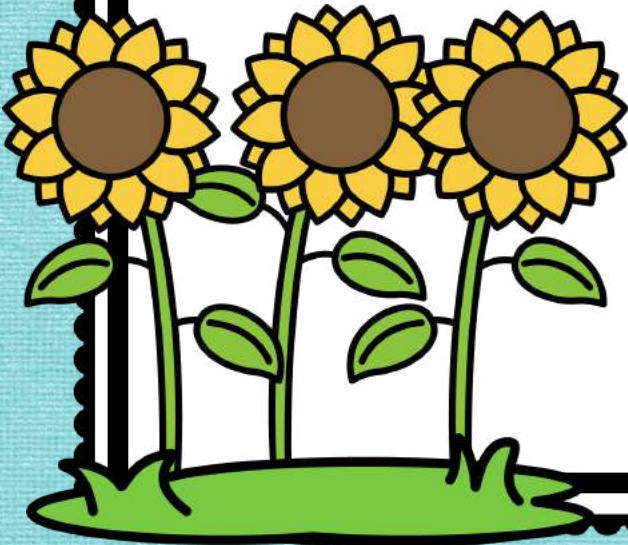

# 5 Pretty Sunflowers

5 pretty sunflowers  
Growing in this place.  
We pick one up and put it in a vase.

Now there are 4 pretty sunflowers  
Growing in this place.  
We pick one up and put it in a vase

**Repeat**

No pretty sunflowers  
Growing in this place.  
Time to plant seeds  
In their space.

# 5 Pretty Sunflowers

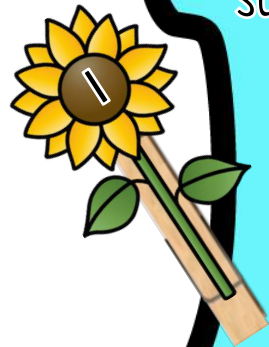

5 pretty sunflowers  
Growing in this place.  
We pick one up and put it in a vase.

Now there are 4 pretty sunflowers  
Growing in this place.  
We pick one up and put it in a vase

**Repeat**

No pretty sunflowers  
Growing in this place.  
Time to plant seeds  
In their space.

Attach the sunflowers to clothes pins.  
Clip each one onto the vase poem.

Brave Astronauts poem

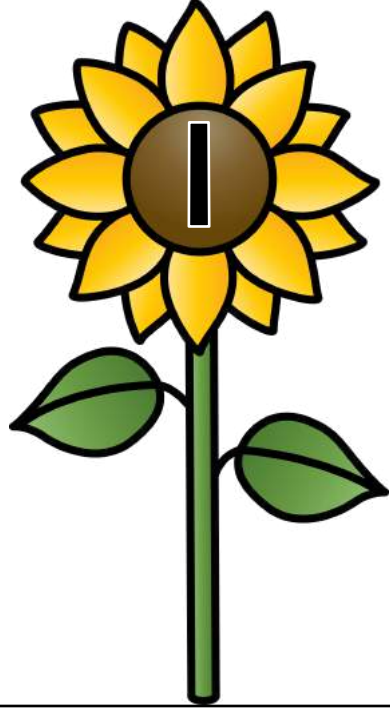

Brave Astronauts poem



Brave Astronauts poem



Brave Astronauts poem



Brave Astronauts poem



Brave Astronauts poem

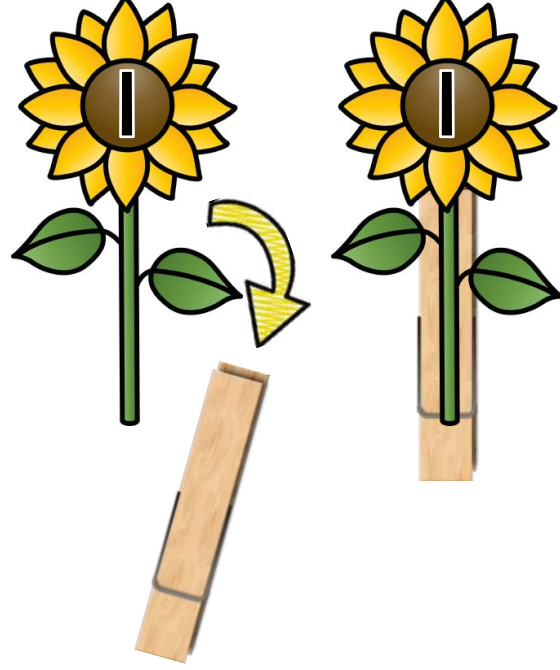

# Sunflower Directed Drawing

Day 7  
Art  
Project

Step  
#1

Show pictures of sunflowers or bring in sunflowers for the class to explore. Point out the petals, stem, and leaves.

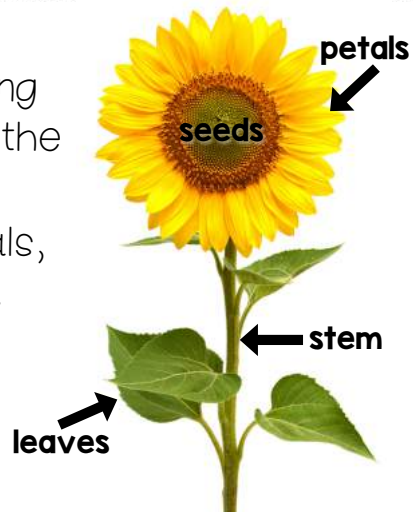

Step  
#2

Gather & distribute the materials:

- white drawing paper
- black markers
- crayons or colored pencils

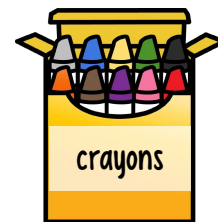
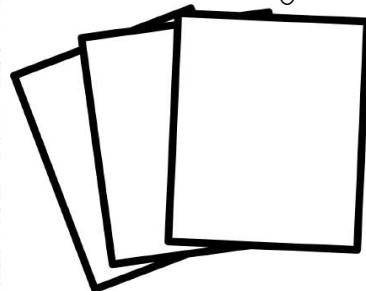

Step  
#3

Direct students in the drawing process:

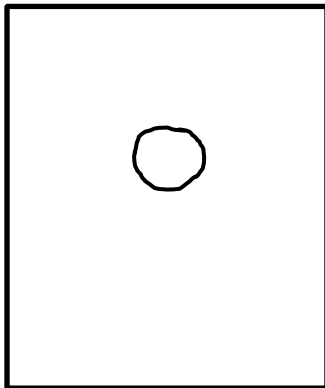

1. Draw a circle in the middle of the page with a black marker.

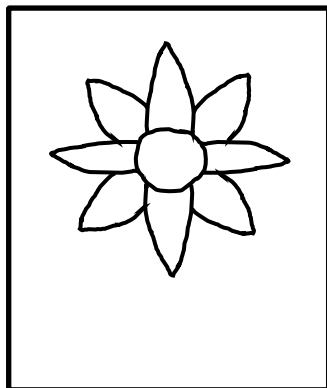

2. Draw pointy petals around the circle with the marker.

Step  
#4

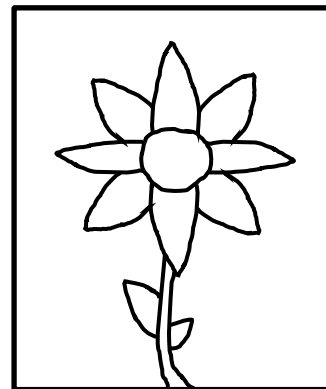

3. Draw a stem and leaves below the flower petals.

4. Color in the picture with crayons or colored pencils.

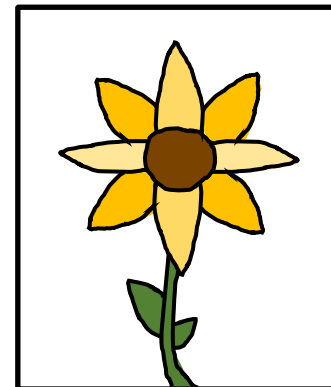

# Alma Thomas

Aal-muh Taa-muhs

Day 8  
Lesson  
Plans

Alma Thomas was an art teacher before becoming a full-time artist after retiring. She drew inspiration from the way light speckled through nature.

## Objectives:

- The students will follow oral directions.
- The students will recognize rhyming words.
- The students will use fine motor skills to produce works of art.

## Activities:

1. Introduce Alma Thomas by reading her biography and showing some of her famous paintings. (Links on the biography page.)
2. Place construction paper around the room at students' eye level (red, pink, yellow, green, blue, and purple). Assemble the color wheel, recite the poem "Colors," and spin the wheel. Students move to the colored paper based on the color spun. Repeat as desired for practice in recognizing colors and active listening skills.
3. Pass out an easel pair card to each student. Take turns saying the words. If the pictures rhyme, the students say "Aw-yeah!". If the pictures do not rhyme, the students cross their arms.
4. Follow the steps to create an Alma Thomas inspired color field abstract piece of art.

### Alma Thomas

**Biography** Sept. 22, 1891  
Feb. 24, 1988

Alma Thomas was born in Columbus, Georgia in 1891. She lived with her mother, father, and four younger sisters. When she was 16, her family moved to the capital of the United States, Washington, D.C. She went to Howard University and studied art in college. After graduating, she taught art to middle school students in D.C. for over thirty-five years! It wasn't until after she retired from teaching that her art career really took off.

While her early art work was mostly realistic, Alma found inspiration in things like space and nature. She would look at her garden or at satellite photos from space and began to create abstract works of art. Alma was 81 years old when her art was honored by having it featured on a special exhibition at the Whitney Museum of Art in New York City.

**Famous Works:**

- *Trip, Tulip, Umbrella, and Dandelion* - 1964
- *Circle* - 1979

**Fun Facts:**

- Michelle Obama had Ms. Thomas' work installed as a permanent piece in the White House collection.
- Her artwork was featured on a United States stamp in 2005.

**Famous Quote:**

"Through color I have sought to concentrate on beauty and happiness..."

Scan for more information



## Colors

Movement Game

Red, blue, yellow, and green.  
Look around,  
What colors can be seen?

Spin the wheel,  
Where will it land?  
Find that color  
Go there and stand.

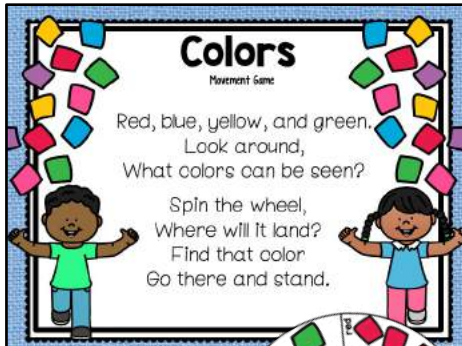

### Color Field Art

Day 8 Art Project

**Step 1:** Gather the materials:  
• colorful construction paper  
• glue sticks  
• heavy white art paper

**Step 2:** The students will rip the paper into small pieces. Collect the pieces, by color, into small baskets.

**Step 3:** Fold the white paper into columns. Model how to glue the small pieces onto the page in columns.

**Step 4:** Provide time for students to create their own Alma Thomas inspired artwork.

\* Alternatively, students could practice paint brush skills by painting small smudges on the page behind the color field art.

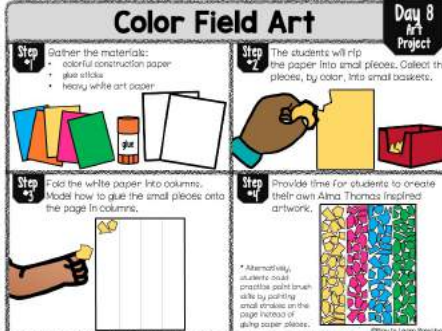

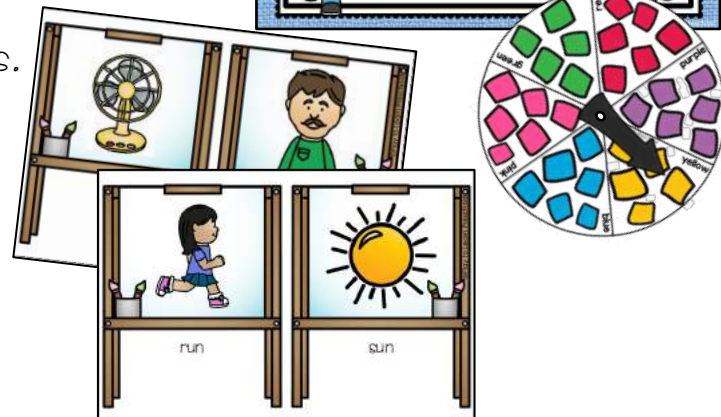

The illustration shows a classroom setting with several easels. One easel has a fan on it. Another has a drawing of a boy's face. Below the easels, there are two more easels with drawings of a girl running and a sun. The words "run" and "sun" are written below these drawings. To the right, there is a large circular color wheel with a black arrow pointing to a section. The wheel is divided into sections of different colors: red, blue, yellow, green, purple, and pink. The words "red", "blue", "yellow", "green", "purple", and "pink" are written around the wheel.

## Literacy Extension:

Read "Ablaze with Color" by Jeanne Harvey.

# Alma Thomas

Abstract  
Painting

## Biography

Sept. 22, 1891

Feb. 24, 1978

Alma Thomas was born in Columbus, Georgia in 1891. She lived with her mother, father, and four younger sisters. When she was 16, her family moved to the capital of the United States, Washington, D.C.

She went to Howard University and studied art in college. After graduating, she taught art to middle school students in D.C. for over thirty-five years! It wasn't until after she retired from teaching that her art career really took off.

While her early art work was mostly realistic, Alma found inspiration in things like space and nature. She would look at her garden or at satellite photos from space and began to create abstract works of art. Alma was 81 years old when her art was honored by having it featured as a solo exhibition at the Whitney Museum of Art in New York City.

## Famous Works:

- [Iris, Tulips, Jonquils, and Crocuses](#) - 1969
- [Orion](#) - 1973

## Fun Facts:

- Michelle Obama had Ms. Thomas' work installed as a permanent piece in the White House collection.
- Her artwork was featured on a United States stamp in 2005.

## Famous Quote:

"Through color I have sought to concentrate on beauty and happiness..."

Scan for more information



[https://nmwa.org/art/artists/  
alma-woodsey-thomas/](https://nmwa.org/art/artists/alma-woodsey-thomas/)

# Colors

## Movement Game

Red, blue, yellow, and green.

Look around,

What colors can be seen?

Spin the wheel,

Where will it land?

Find that color

Go there and stand.

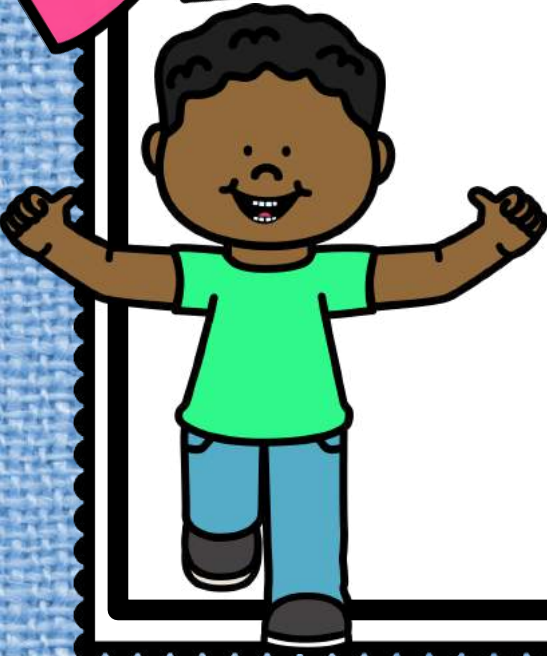

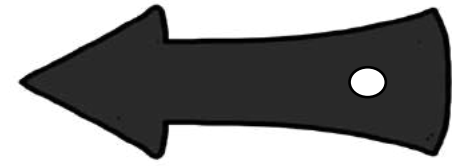
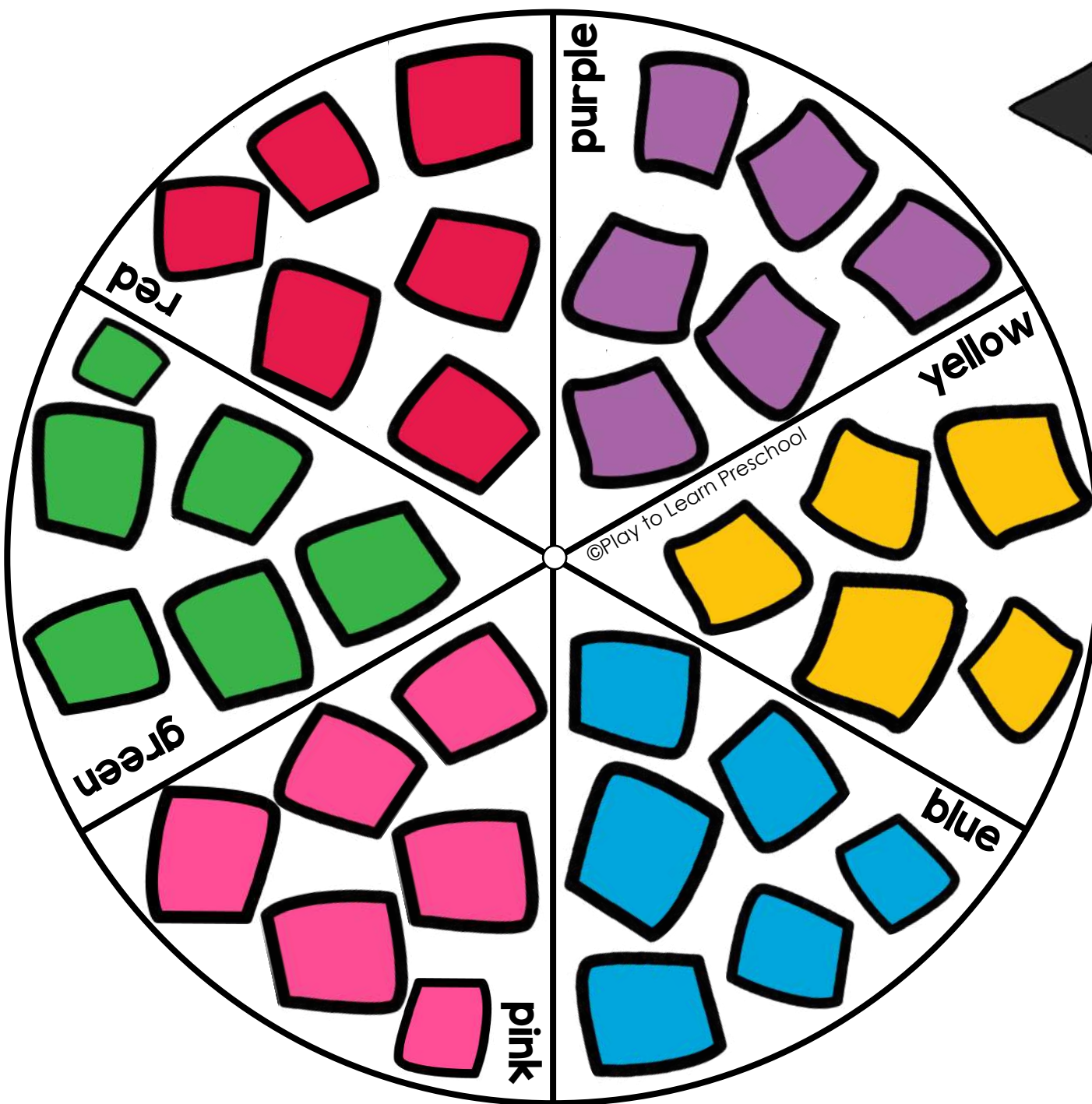

**To Assemble:**

Print the spinner on heavy cardstock or back to cardboard. Make and assemble the "action spinner." Open up a paper clip, push one end through the arrow and then the spinner. Fold the end of the paperclip down the back and secure with tape. Twist the other end to ensure the arrow does not fall off. (see diagram below)

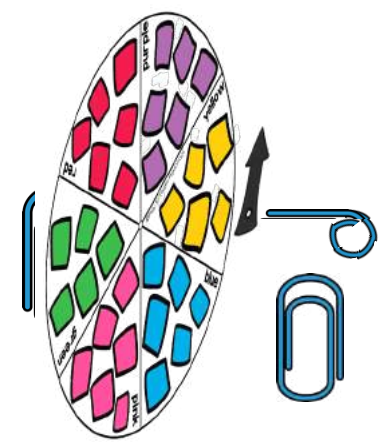

Does it rhyme?

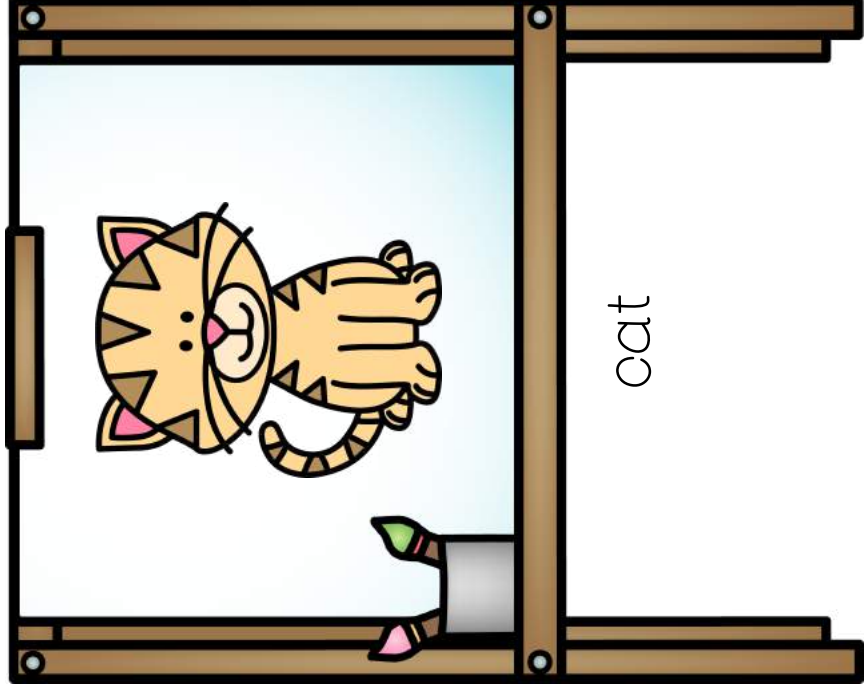

cat

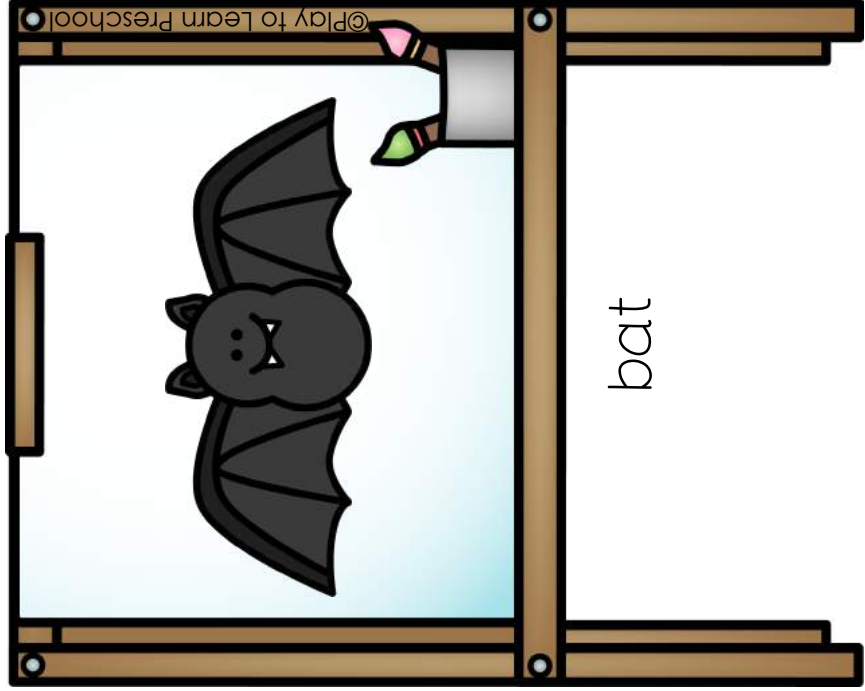

bat

©Play to Learn Preschool

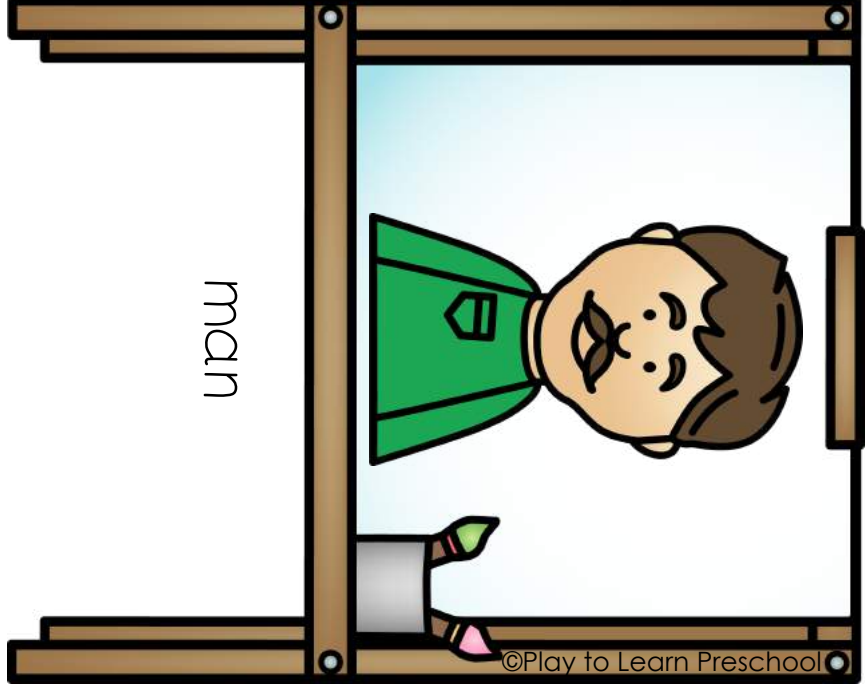

man

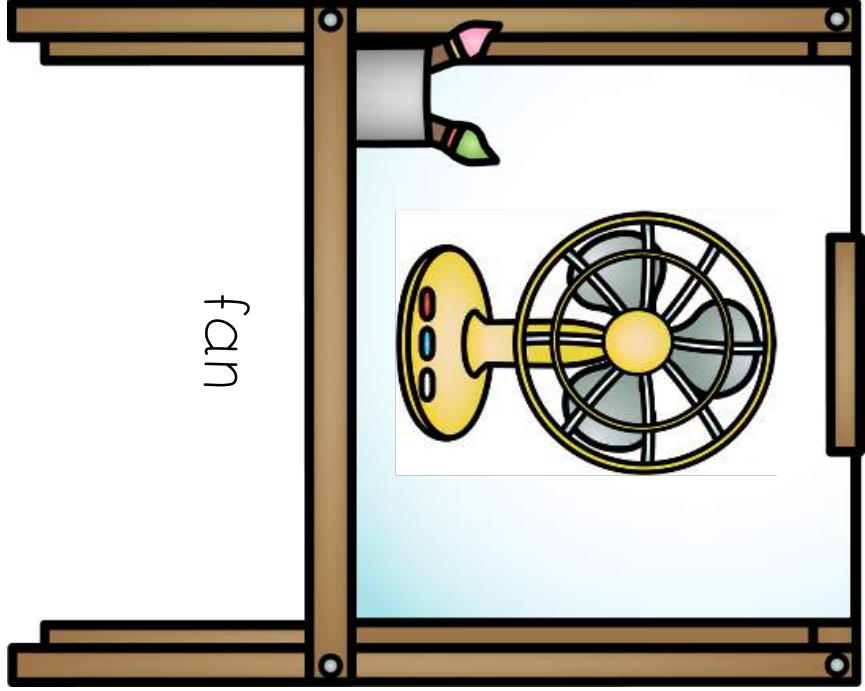

fan

Does it rhyme?

©Play to Learn Preschool

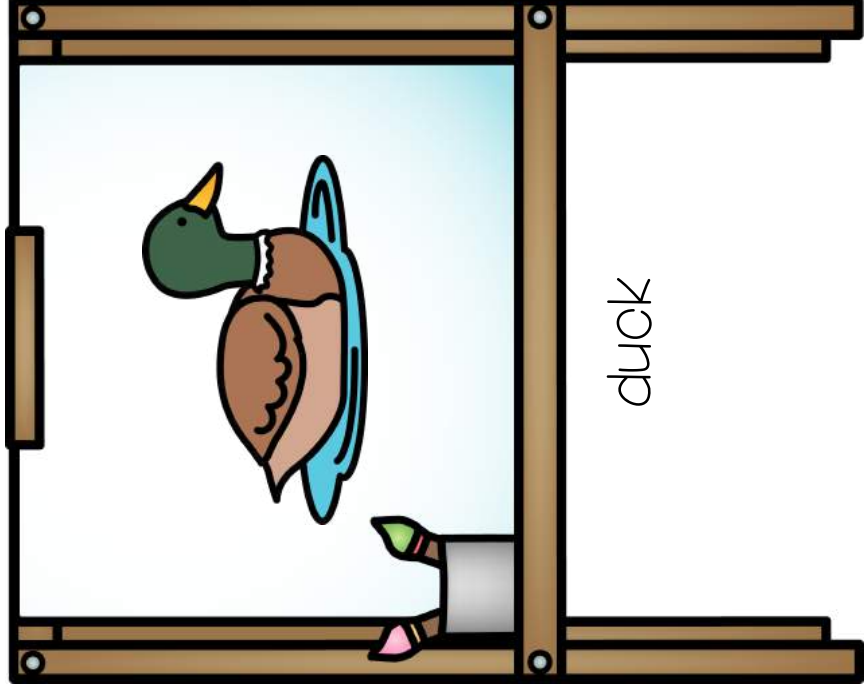

duck

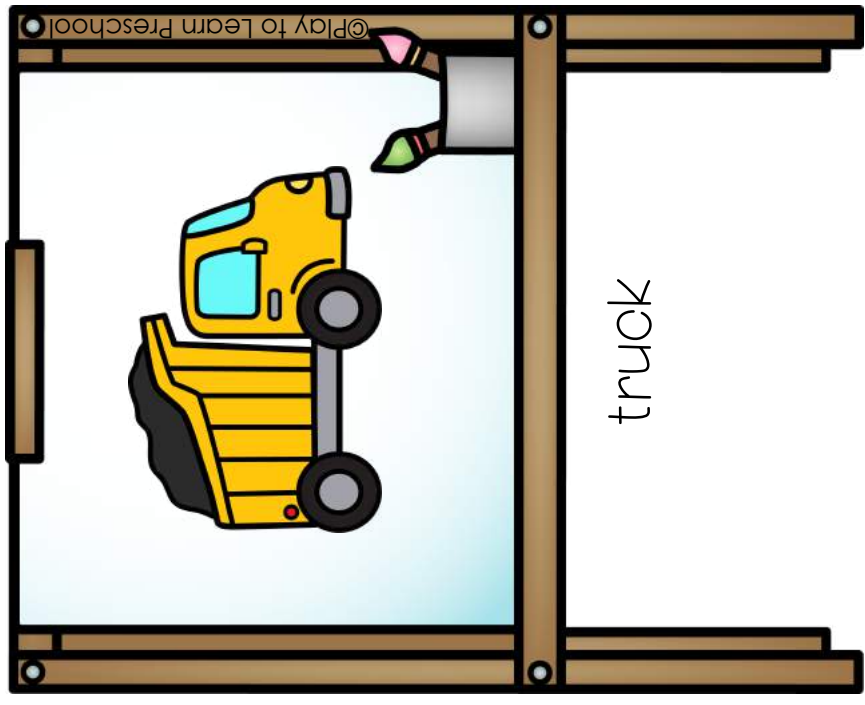

truck

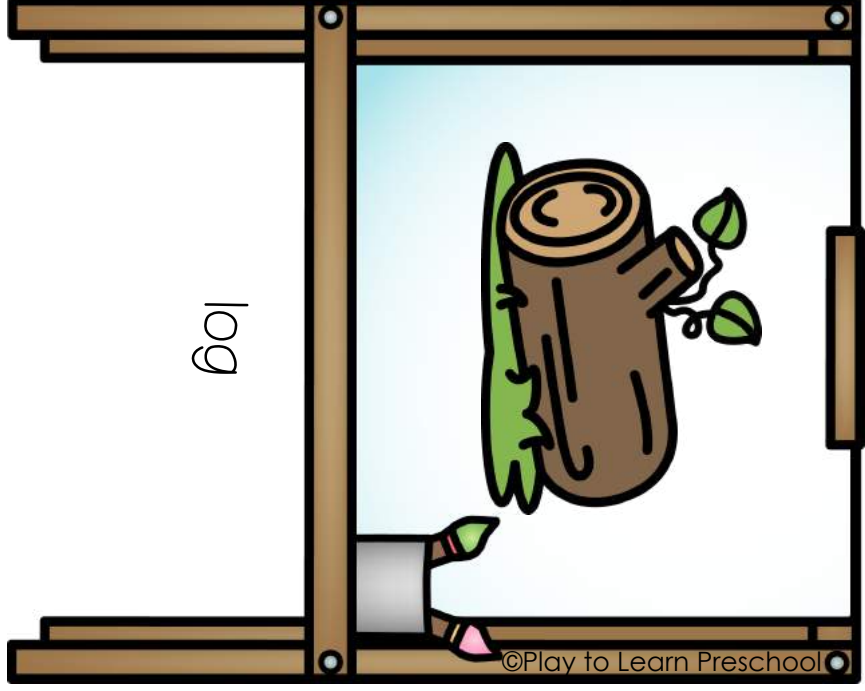

log

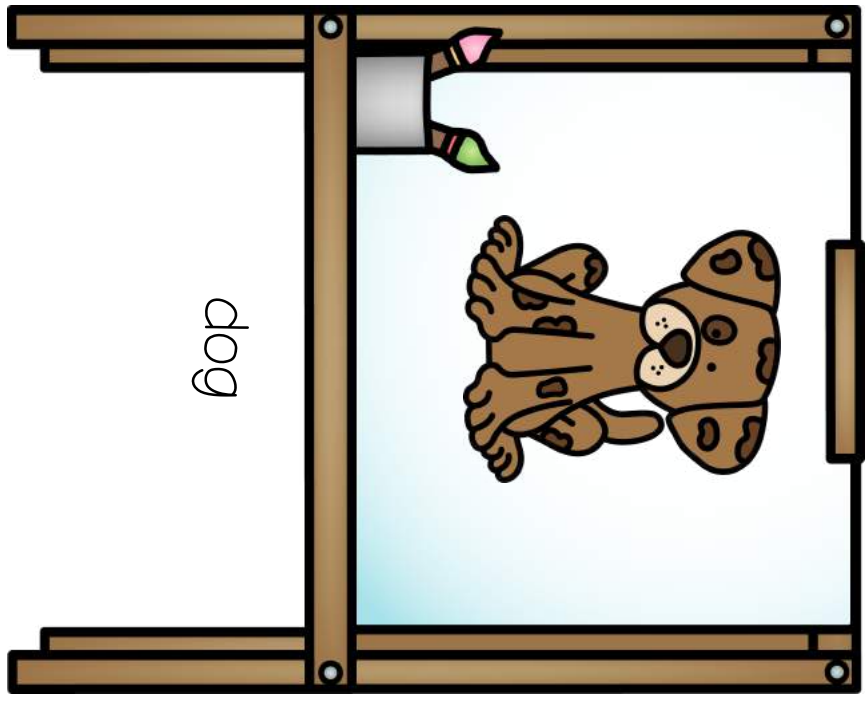

dog

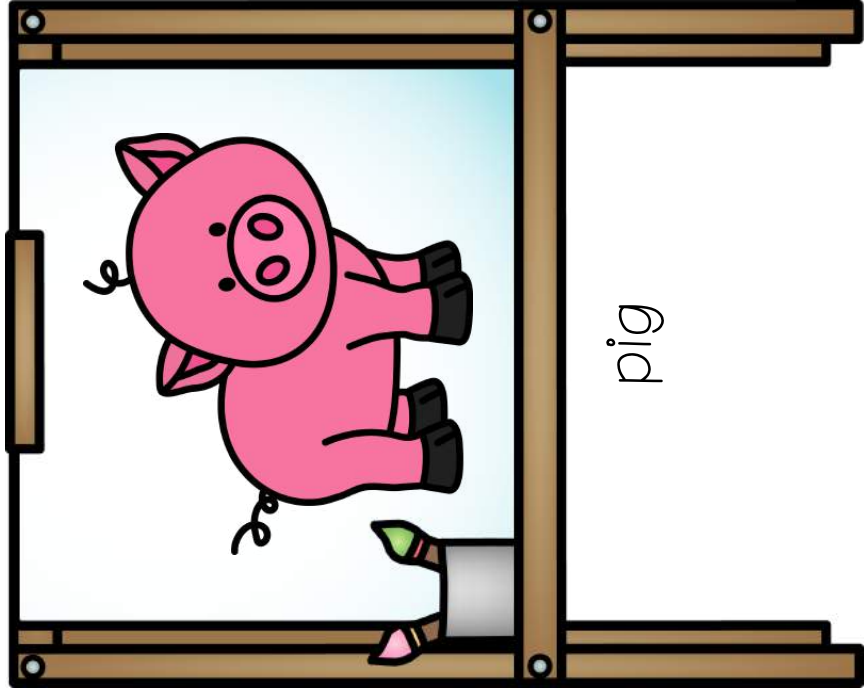

pig

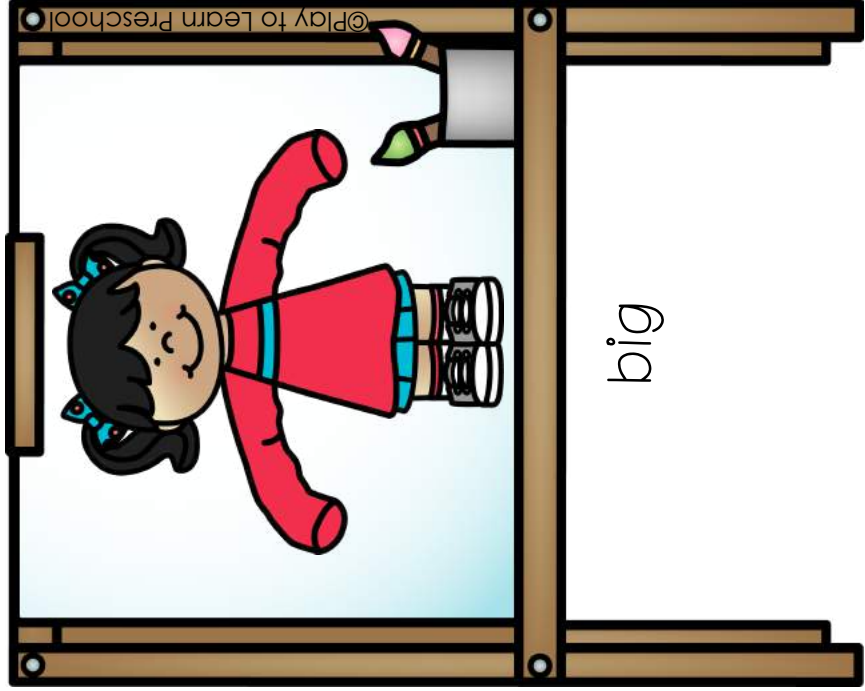

big

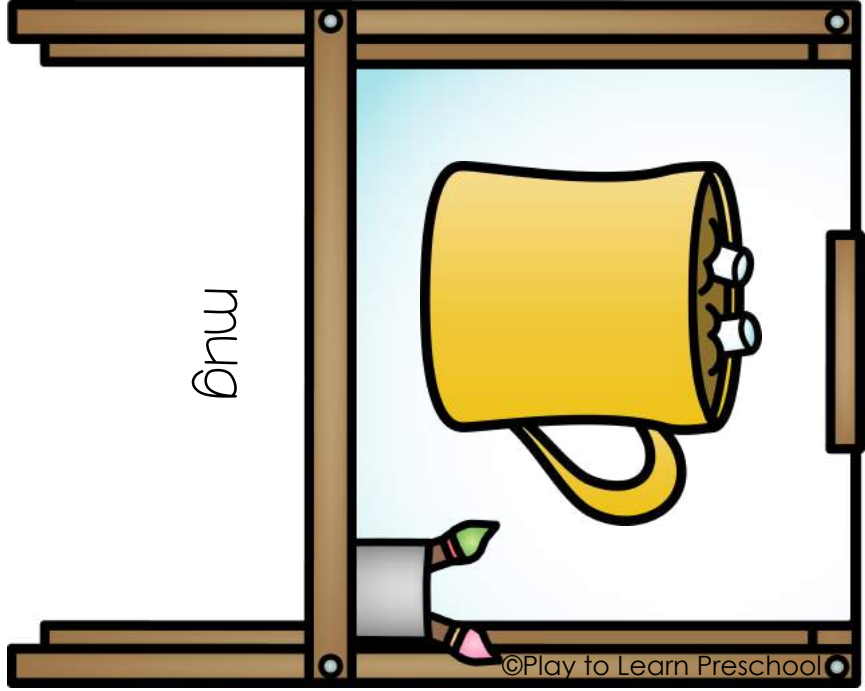

mug

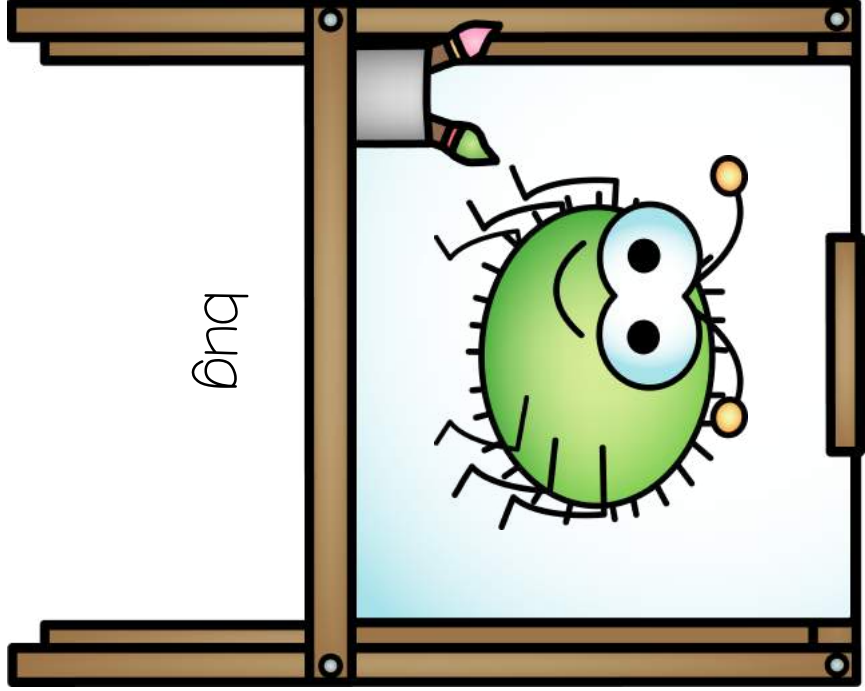

bug

Does it rhyme?

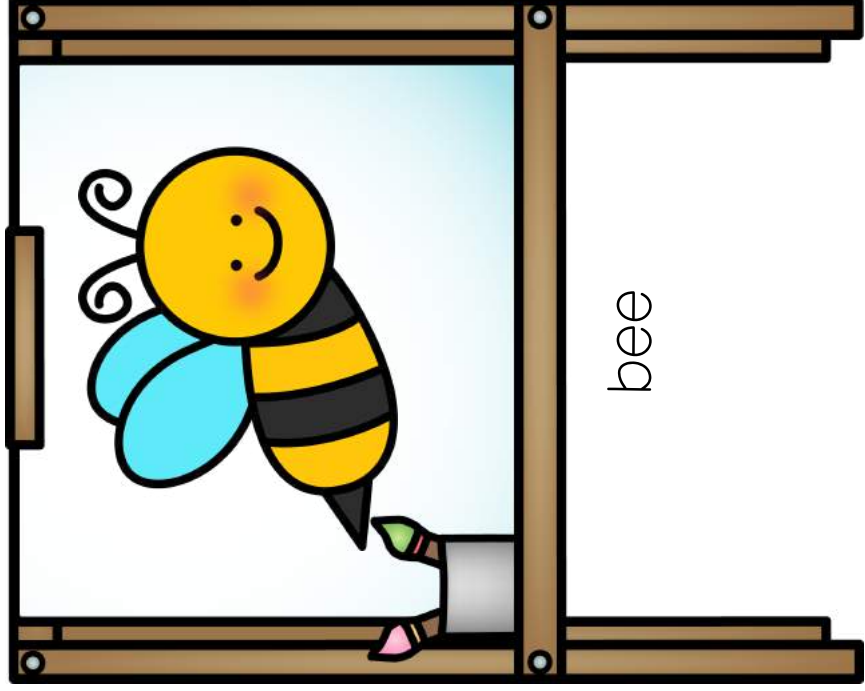

bee

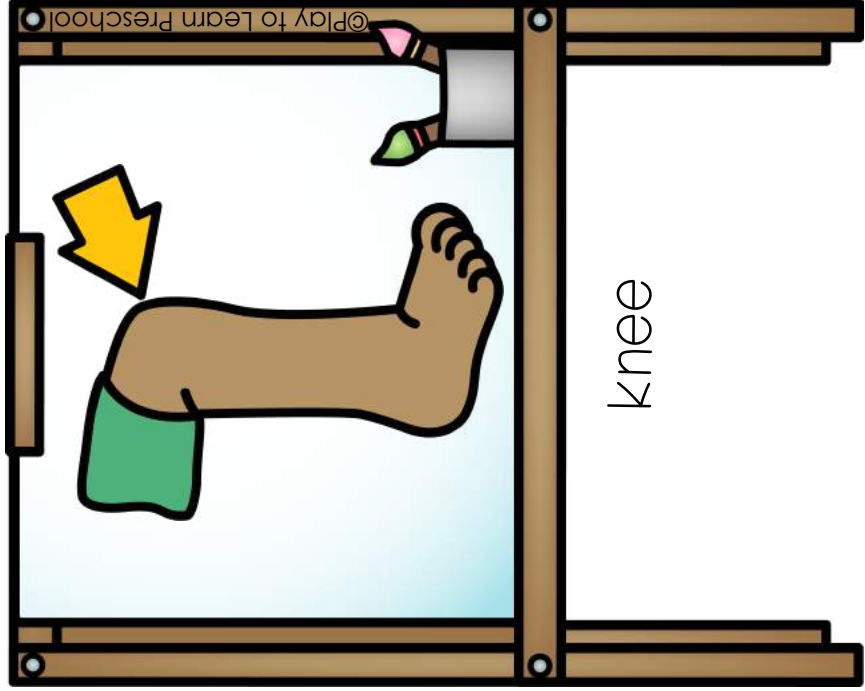

knee

©Play to Learn Preschool

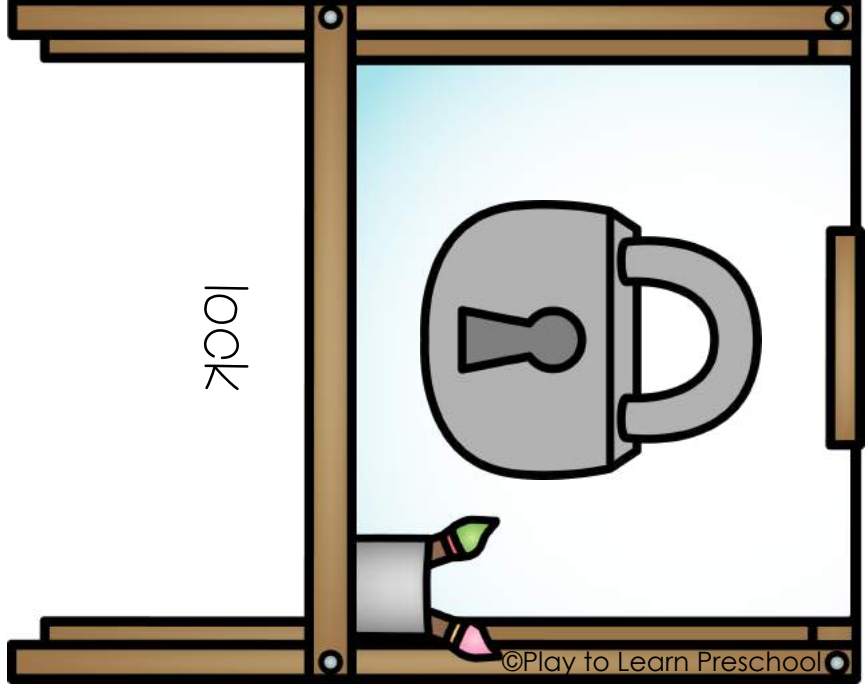

lock

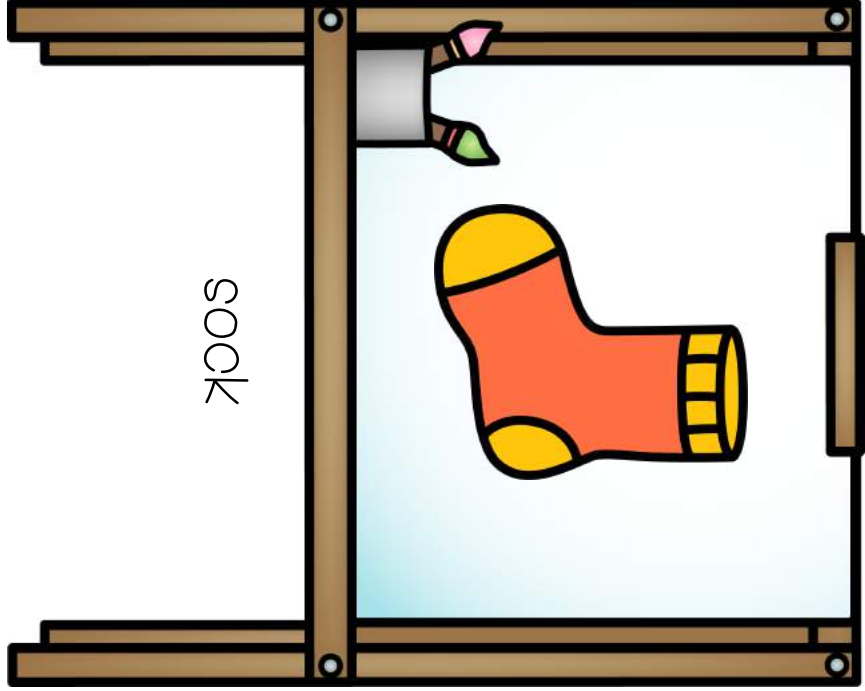

sock

©Play to Learn Preschool

Does it rhyme?

Does it rhyme?

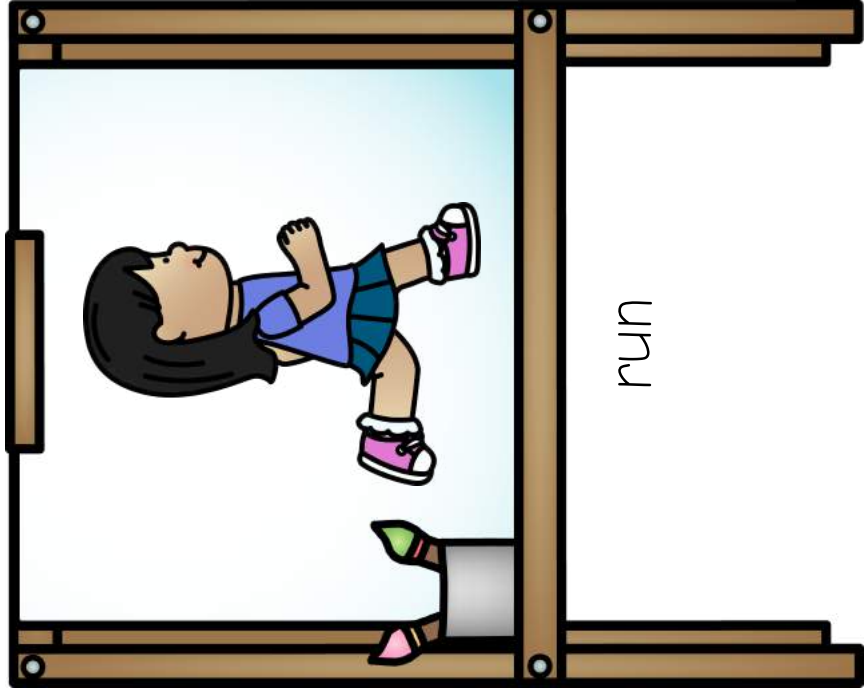

run

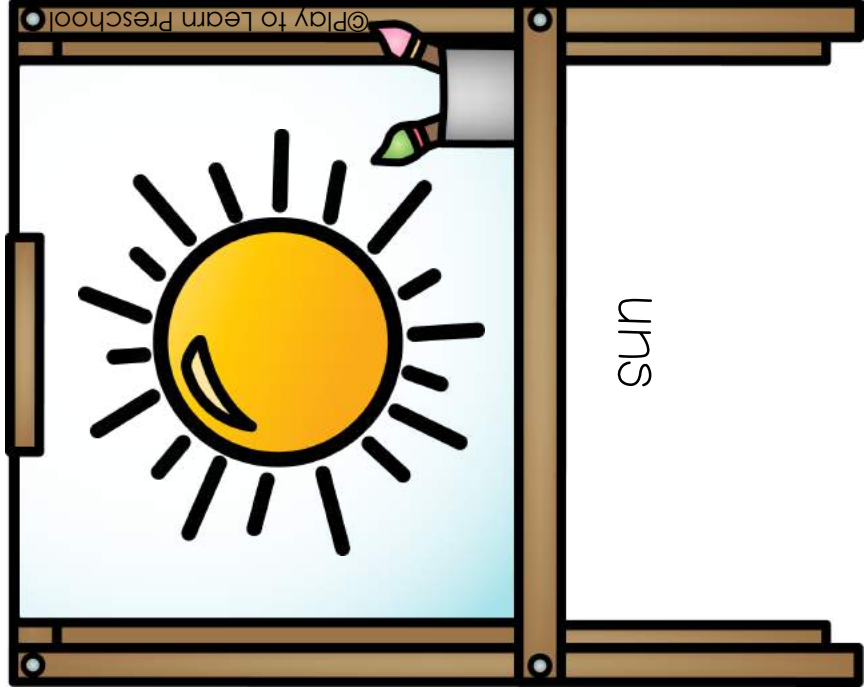

sun

©Play to Learn Preschool

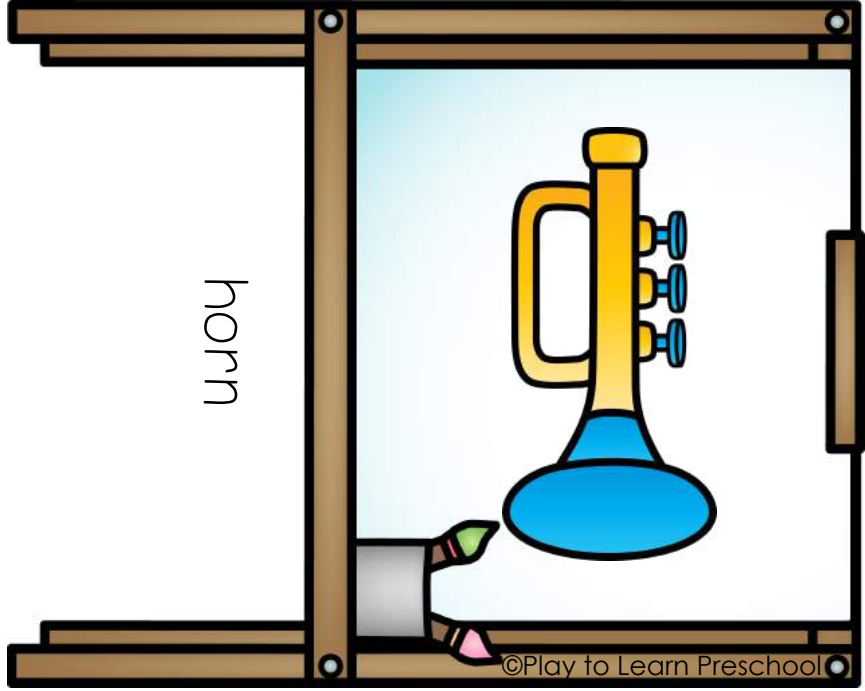

horn

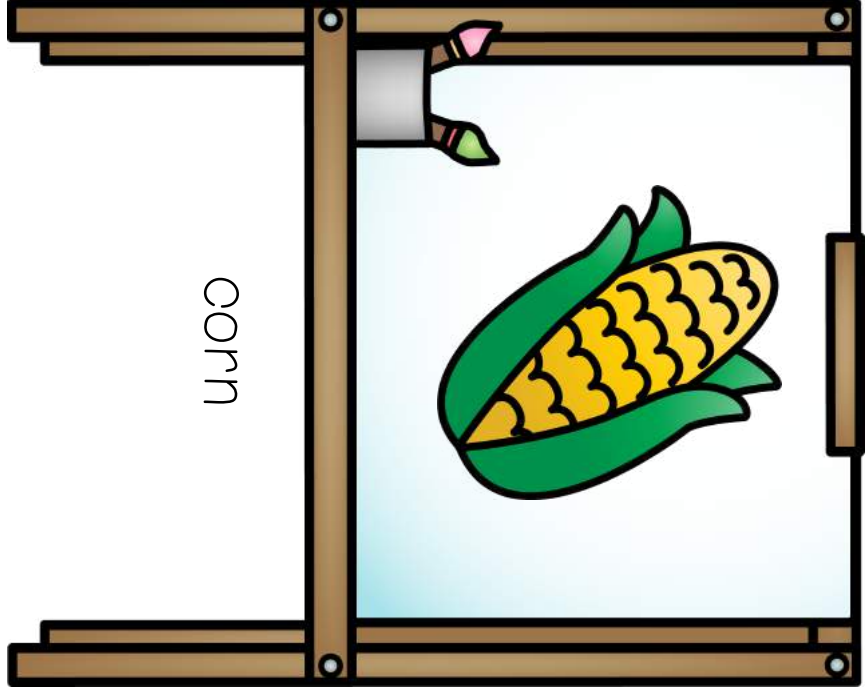

corn

Does it rhyme?

©Play to Learn Preschool

Does it rhyme?

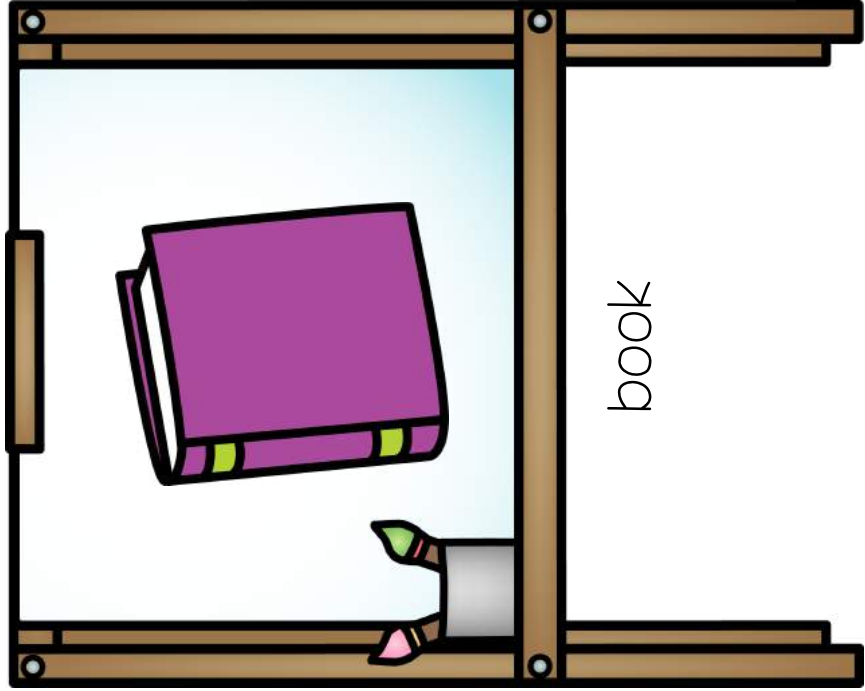

book

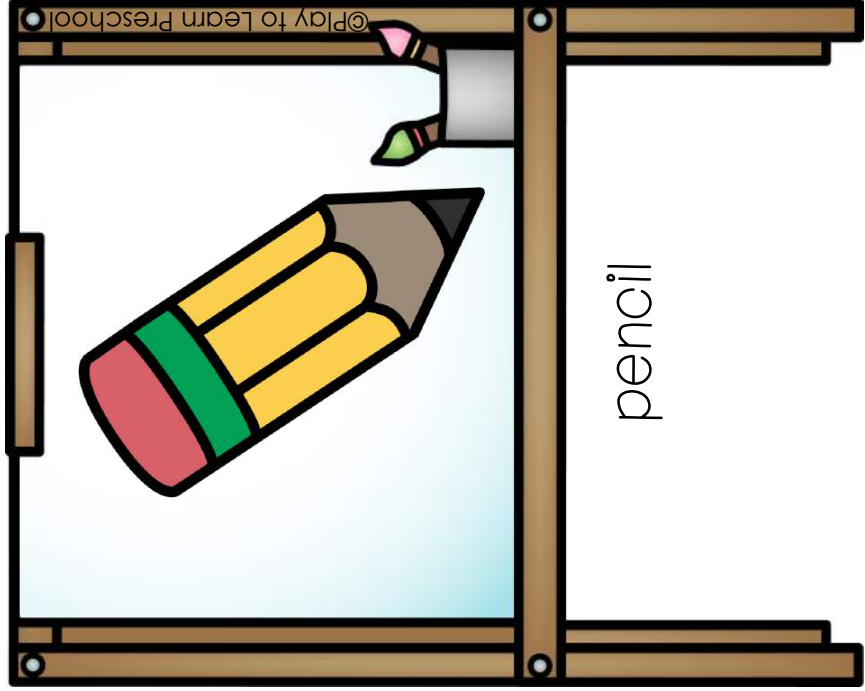

pencil

©Play to Learn Preschool

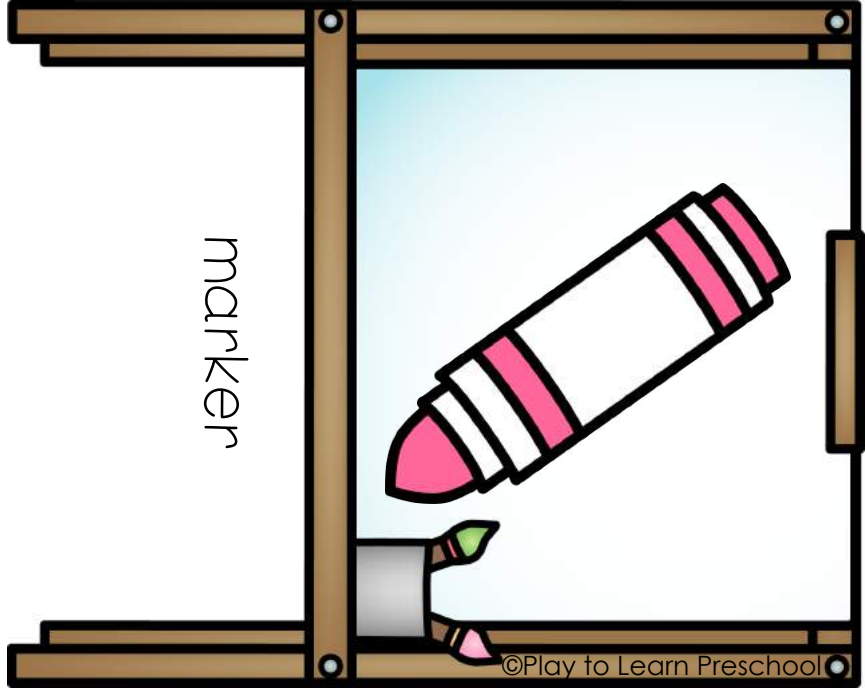

marker

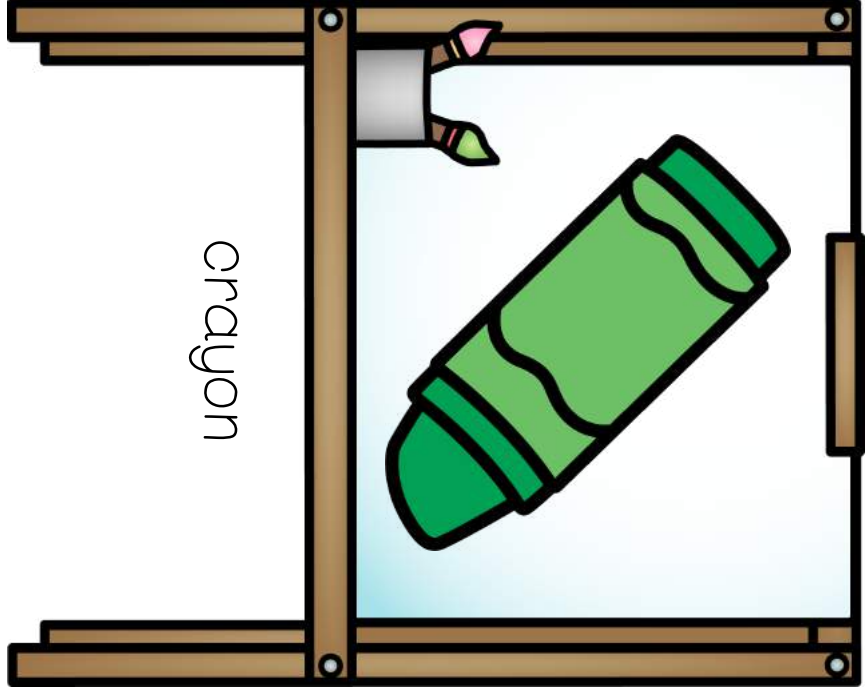

crayon

Does it rhyme?

©Play to Learn Preschool

Does it rhyme?

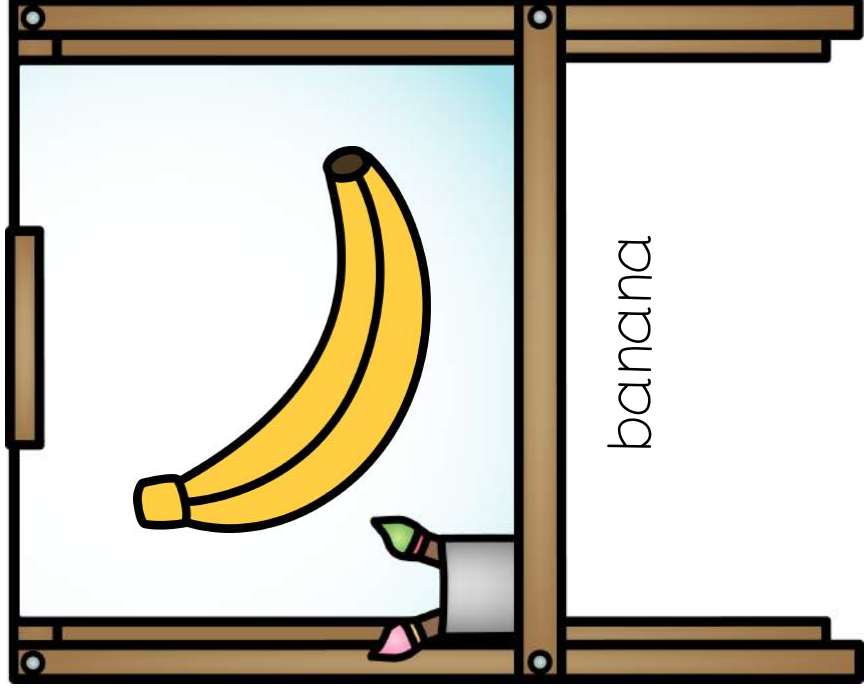

banana

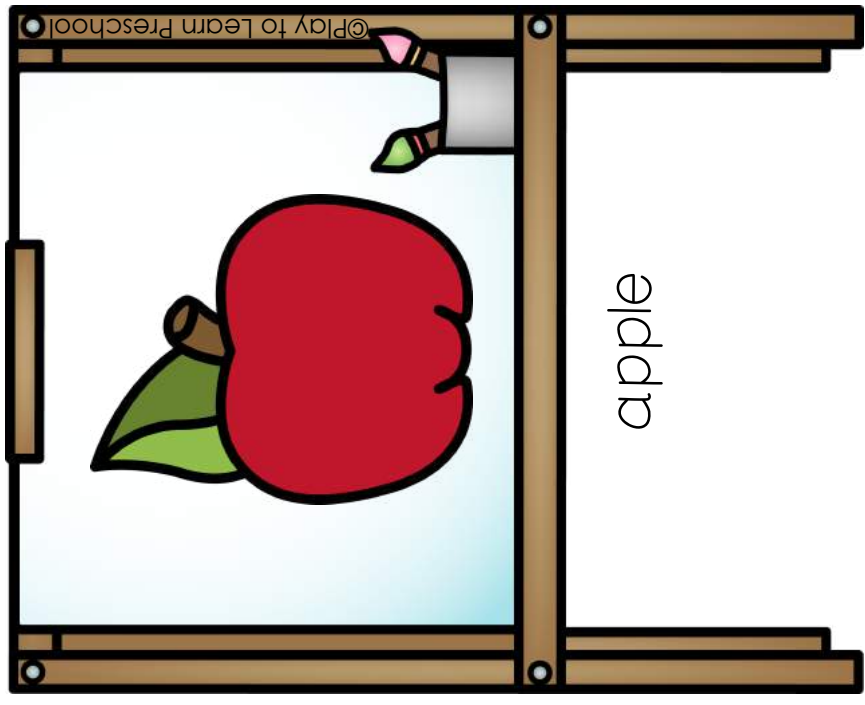

apple

©Play to Learn Preschool

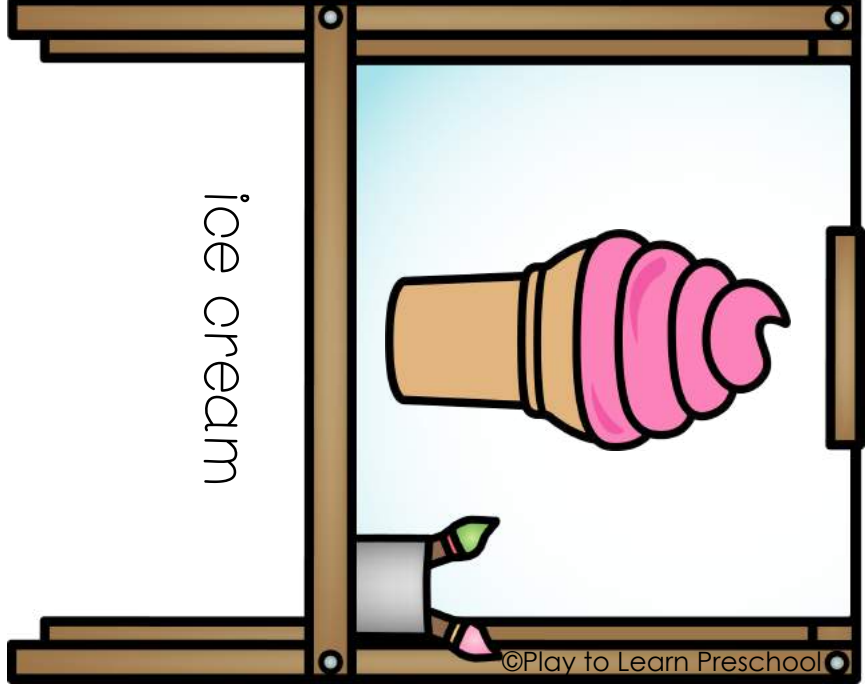

ice cream

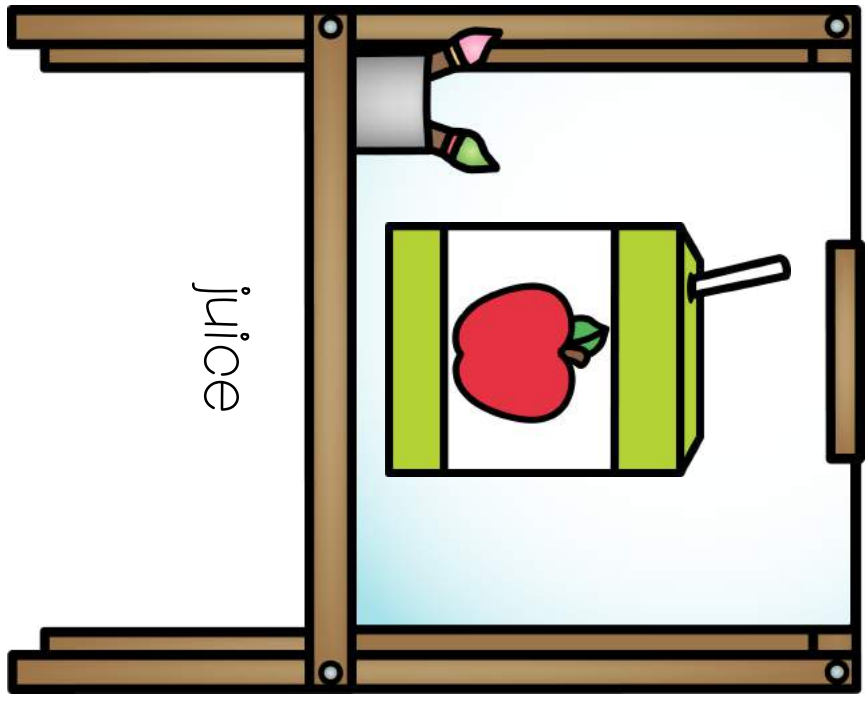

juice

Does it rhyme?

©Play to Learn Preschool

Does it rhyme?

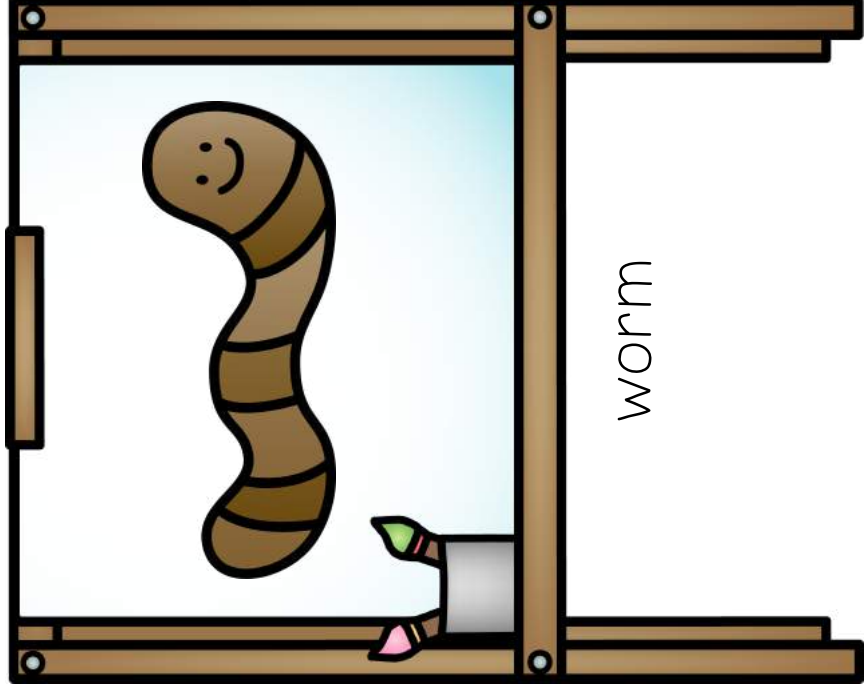

worm

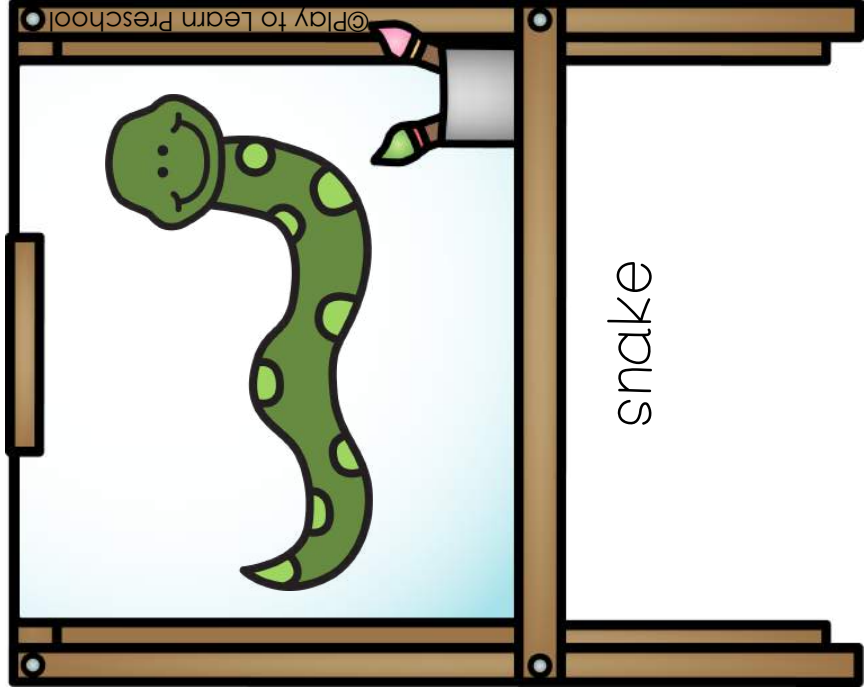

snake

©Play to Learn Preschool

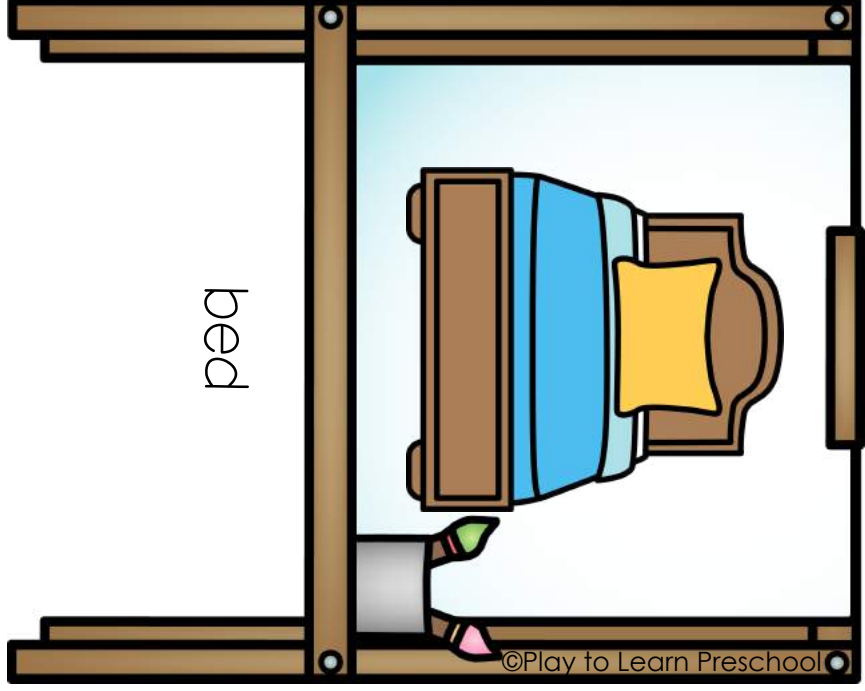

bed

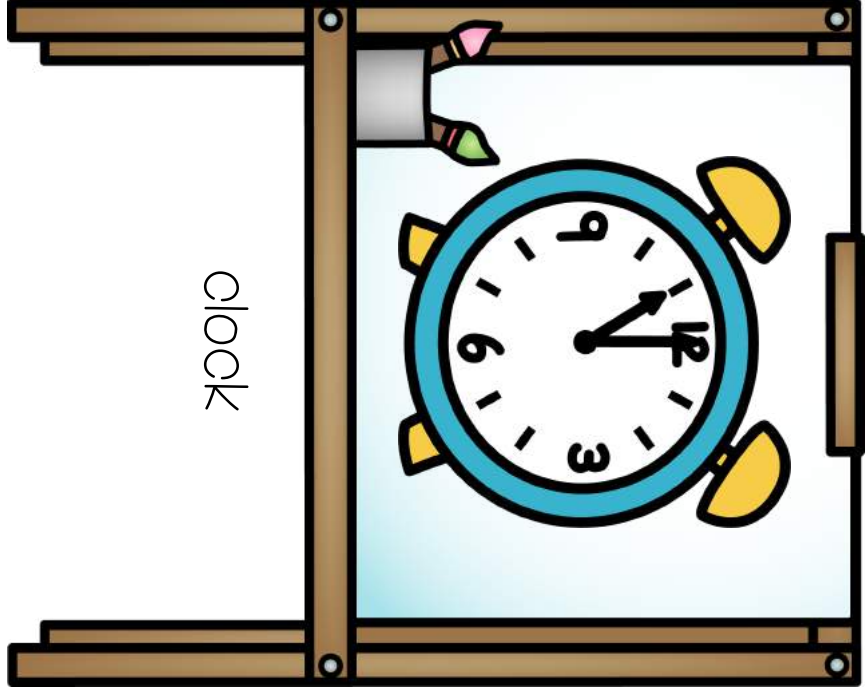

clock

Does it rhyme?

©Play to Learn Preschool

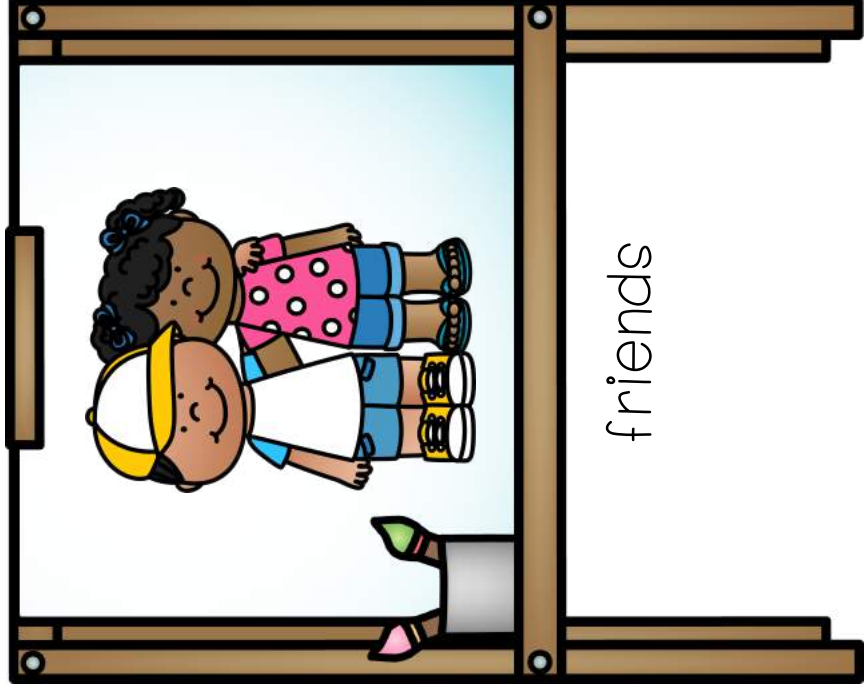

friends

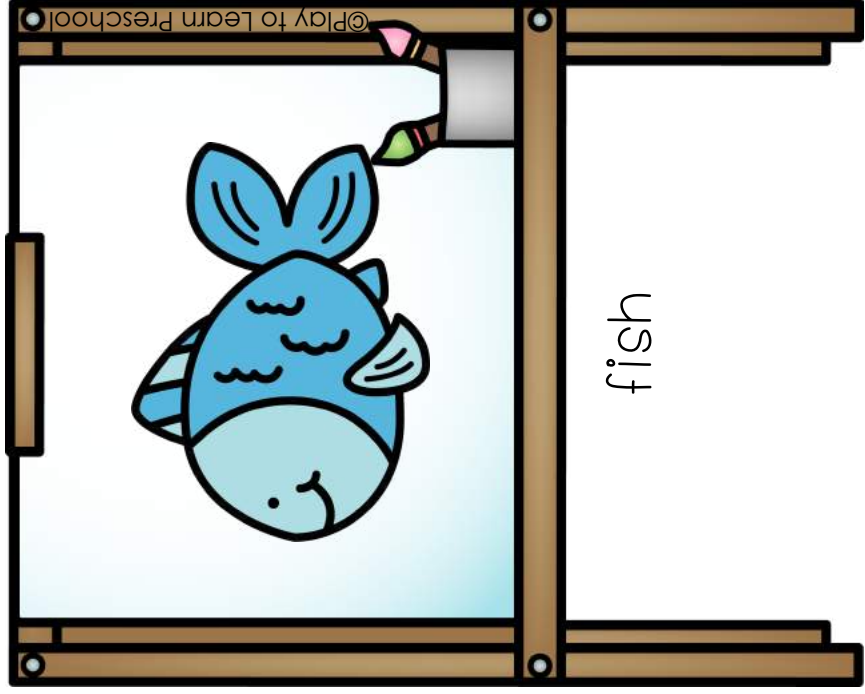

fish

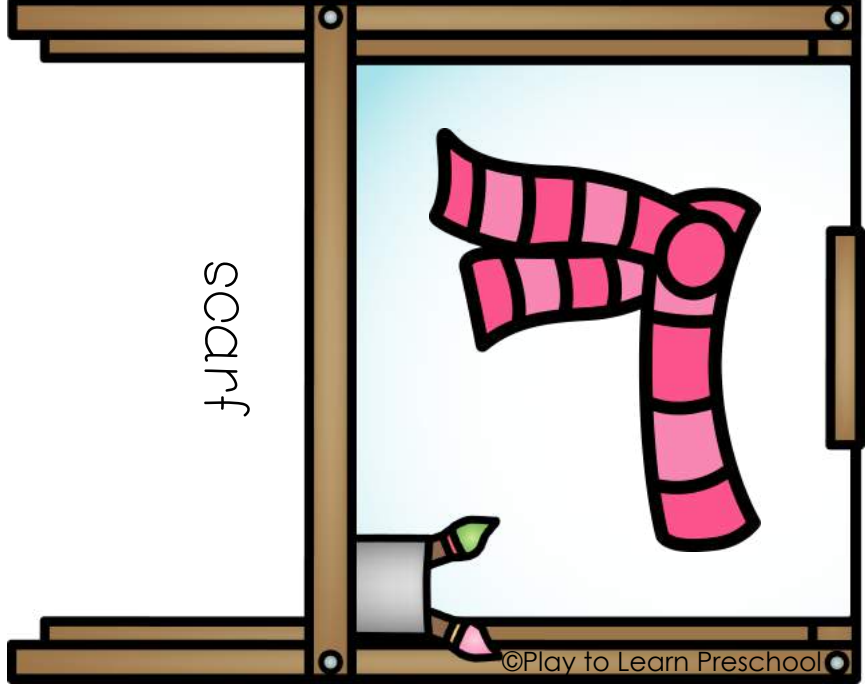

scarf

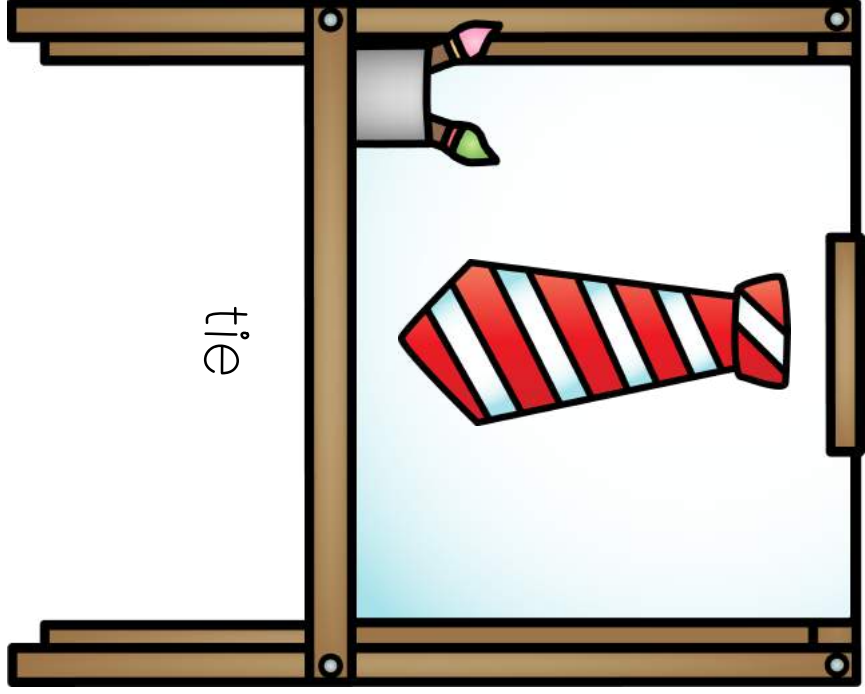

tie

Does it rhyme?

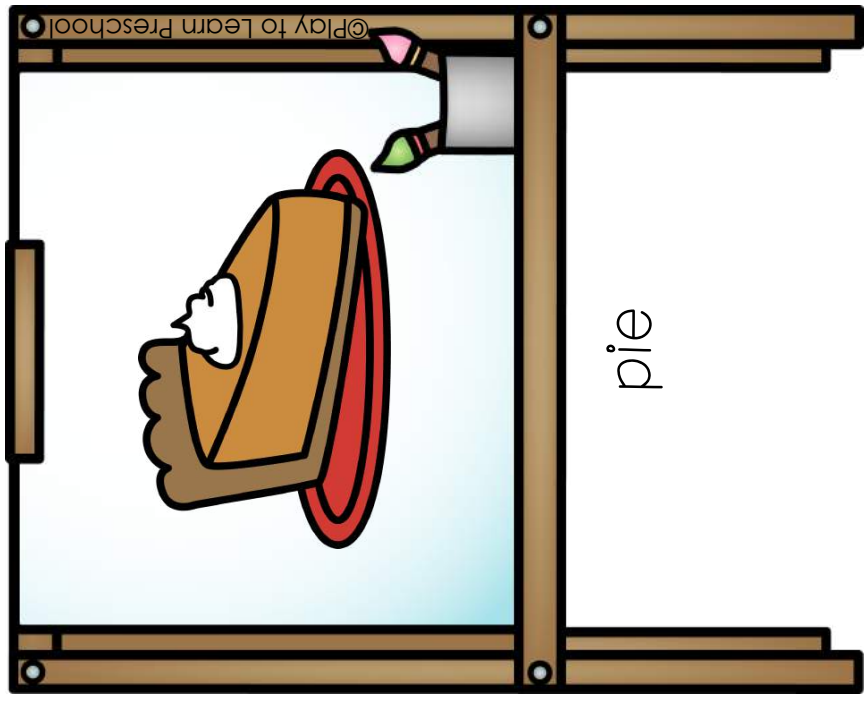
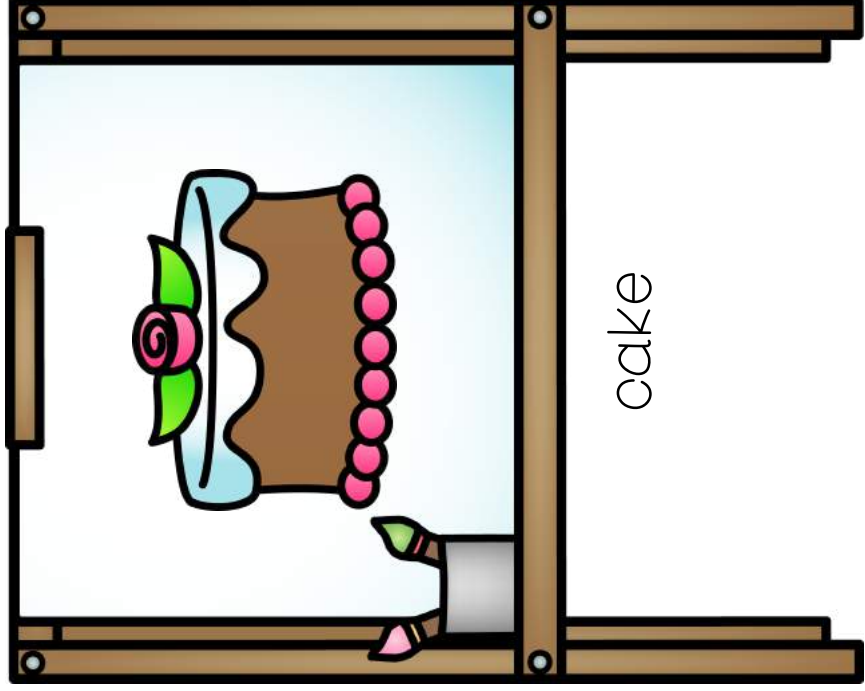

©Play to Learn Preschool

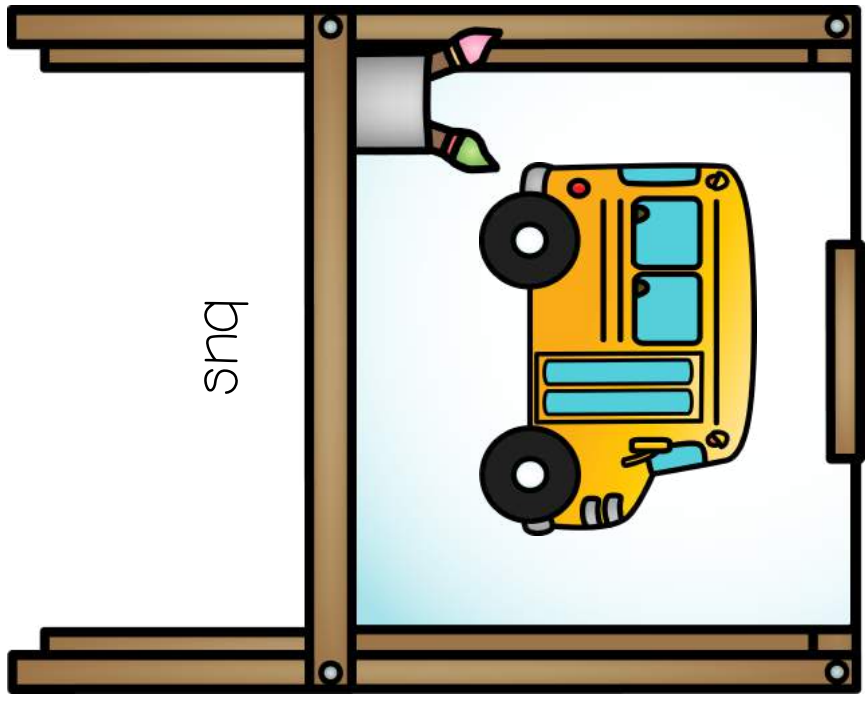
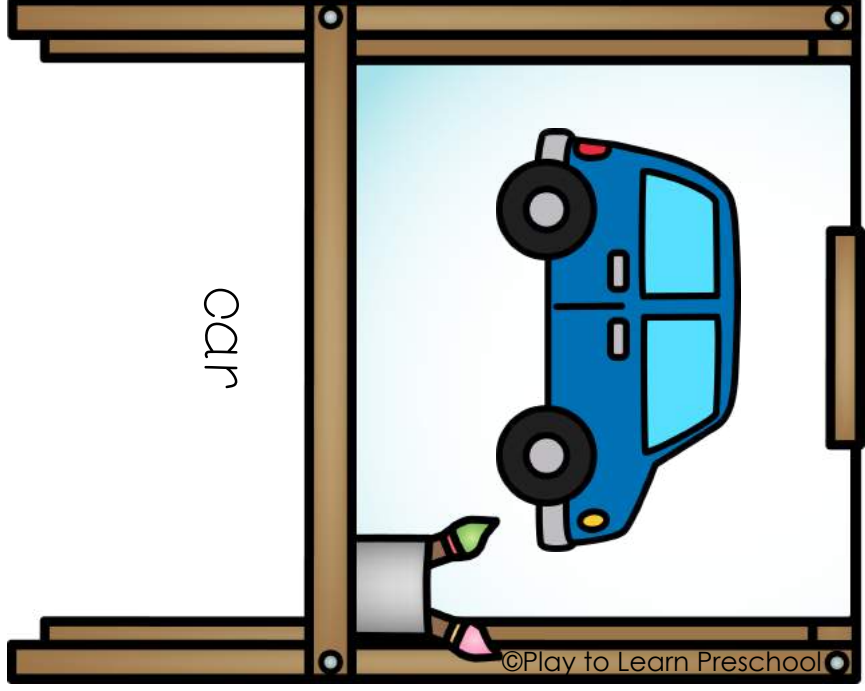

Does it rhyme?

©Play to Learn Preschool

# Color Field Art

Day 8  
Art  
Project

Step  
#1

Gather the materials:

- colorful construction paper
- glue sticks
- heavy white art paper



Step  
#2

The students will rip the paper into small pieces. Collect the pieces, by color, into small baskets.

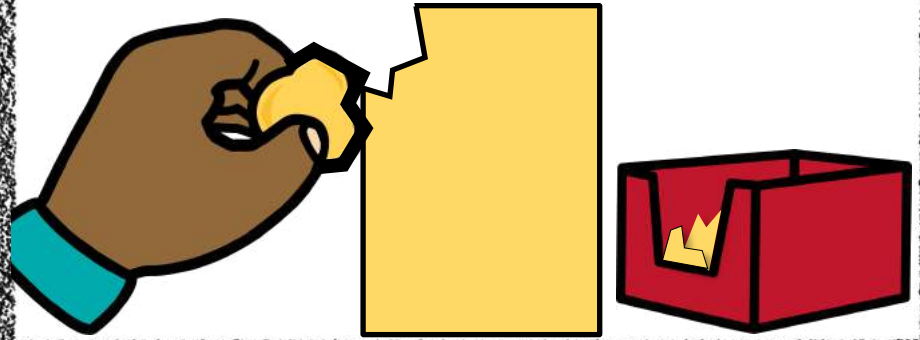

Step  
#3

Fold the white paper into columns. Model how to glue the small pieces onto the page in columns.

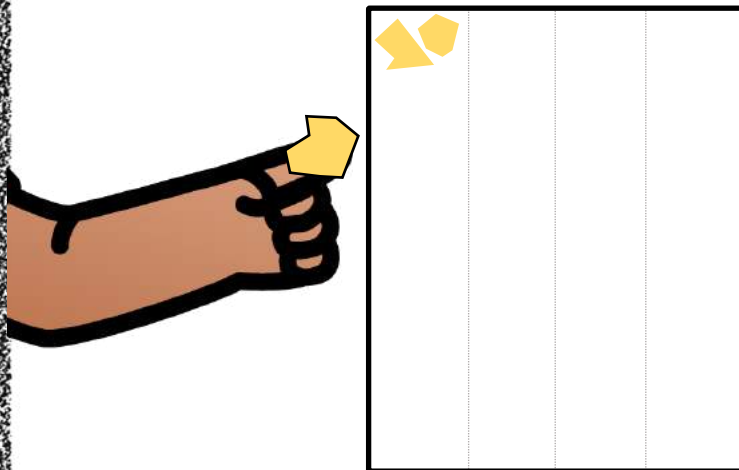

Step  
#4

Provide time for students to create their own Alma Thomas inspired artwork.

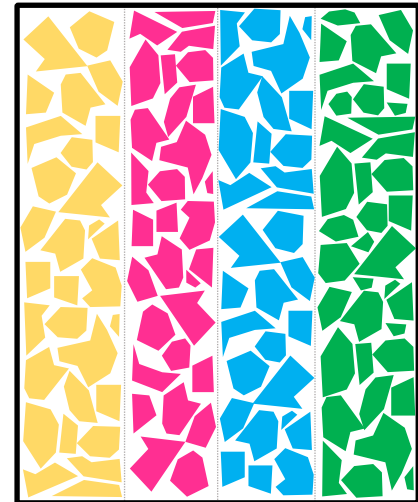

\* Alternatively, students could practice paint brush skills by painting small strokes on the page instead of gluing paper pieces.

# Pablo Picasso

Paa-blow Puh-kaa-sow

Day 9  
Lesson  
Plans

Pablo Picasso is one of the most well-known artists of all time. Although his style changed throughout his career, his artwork is uniquely his own.

## Objectives:

- The students will recognize and identify shapes.
- The students will begin to make letter-sound connections.
- The students will use fine motor skills to produce works of art.

## Activities:

1. Show the real life picture of the artwork. Discuss.
2. Play the "Letter P" caret game.
3. Recite the "I Know My Shapes" call-back chant using the picture cards. Point out the attributes of each shape after it is identified (ie. a square has 4 equal sides, a circle is round, etc.).
4. Follow the steps to create a Pablo Picasso inspired face collage.

### Pablo Picasso

Oct. 25, 1881  
April 8, 1973

#### Biography

Pablo Picasso was born in Spain in 1881. He lived with his mother, father, and two younger sisters. His father was an artist himself and taught art at a local school. Pablo was interested in art from a very early age. Through the years, Picasso's work went through many different phases. He would paint mainly in blue when he was sad and warmer colors like reds and pinks when he was in love. Some of his most famous works began when he started painting in a new style called "cubism." This style of painting looks like a picture was taken apart in pieces, then put back together in a completely different way. It became one of Picasso's signature styles.

#### Famous Works:

- *Woman with Mustard Pie* - 1910
- *Portrait of Olga Muz* - 1937
- *The Weeping Woman* - 1937

#### Fun Facts:

- Pablo Picasso produced over 145,000 works of art including paintings, sculptures, and engravings.
- Many of his paintings have sold for over \$100 million!

#### Famous Quote:

"The meaning of life is to find your gift. The purpose of life is to give it away."

Scan for more information:



©2015 by Linda Ward Beech

## I Know the Shapes

I know the shapes  
Oh yes, I do!  
I know the shapes,  
Do you know them too?



- 4 equal sides
- 3 sides
- 4 sides, opposite sides equal
- round, no straight lines

## To Play the Game:

- Line up the pictures. Pick the right number of cards for your students. Identify the words together. Emphasize that each starts with the letter P like Picasso's name.
- Hide the "P" under one of the pictures and recite the poem to find it.
- Children guess where the letter P is hiding by identifying the number or the item.

## Letter P

Carpet Game

Choose a picture and make its sound.

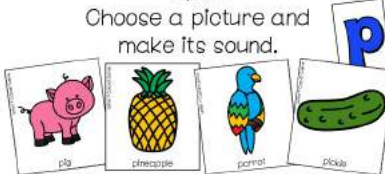

Where will the letter p be found?

### Face Collage Artwork

Day 9 Art Project

**Step 1:** Gather the materials:  
• white drawing paper  
• black marker  
• old magazines to cut apart  
• scissors  
• glue stick

**Step 2:** Pass out materials to students. Model how to draw an oval in the center of the page for the outline of a face.

**Step 3:** Allow students to cut pictures out of magazines that show eyes, nose, mouth, ears, etc.

**Step 4:** Provide time for students to glue pictures onto their paper to create their own Picasso inspired artwork.

\* Students may choose to color the rest of the face on glue other images in the blank space, just like Picasso did!



©2015 by Linda Ward Beech

**Literacy Extension:**  
Read "Picasso Loves Shapes" by Judiee Lee.

# Pablo Picasso

Abstract  
Painting

## Biography

Oct. 25, 1881

April 8, 1973

Pablo Picasso was born in Spain in 1881. He lived with his mother, father, and two younger sisters. His father was an artist himself and taught art at a local school. Pablo was interested in art from a very early age.

Through the years, Picasso's work went through many different phases. He would paint mainly in blue when he was sad and warmer colors like reds and pinks when he was in love. Some of his most famous works began when he started painting in a new style called 'cubism.'

This style of painting looks like a picture was taken apart in pieces, then put back together in a completely different way. It became one of Picasso's signature styles.

## Famous Works:

- [Woman with Mustard Pot](#) - 1910
- [Portrait of Dora Maar](#) – 1937
- [The Weeping Woman](#) – 1937

## Fun Facts:

- Pablo Picasso produced over 145,000 works of art including paintings, sculptures, and engravings.
- Many of his paintings have sold for over \$100 million!

## Famous Quote:

“The meaning of life is to find your gift. The purpose of life is to give it away.”

Scan for more information



[https://kids.kiddle.co/  
Pablo\\_Picasso](https://kids.kiddle.co/Pablo_Picasso)

# I Know the Shapes



I know the shapes  
Oh yes, I do!  
I know the shapes,  
Do you know them too?

square

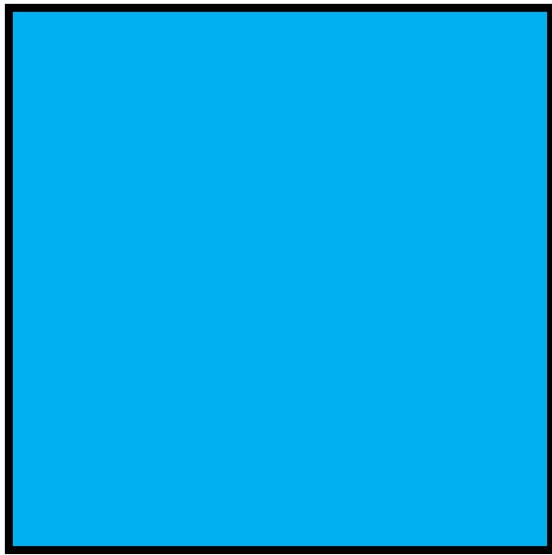

4 equal sides

rectangle



4 sides, opposite sides equal

triangle

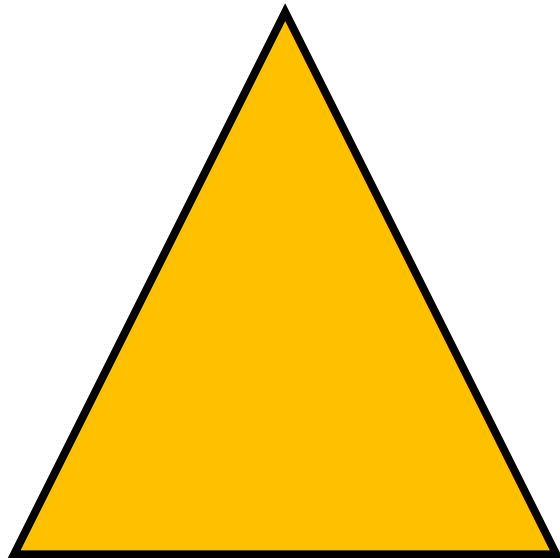

3 sides

circle

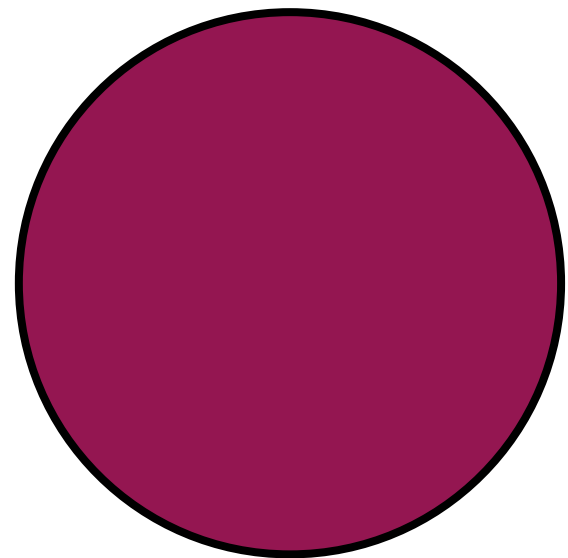

round, no straight lines

pentagon

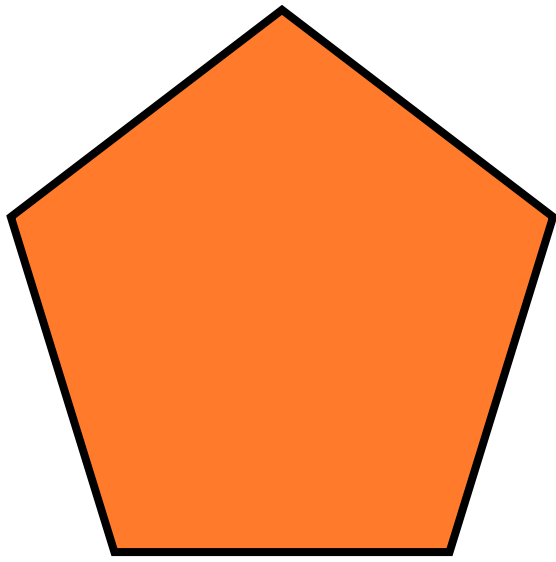

5 sides

trapezoid

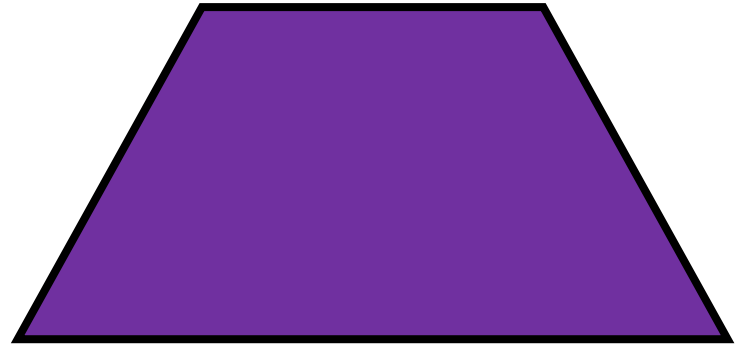

4 sides, top & bottom straight

octagon

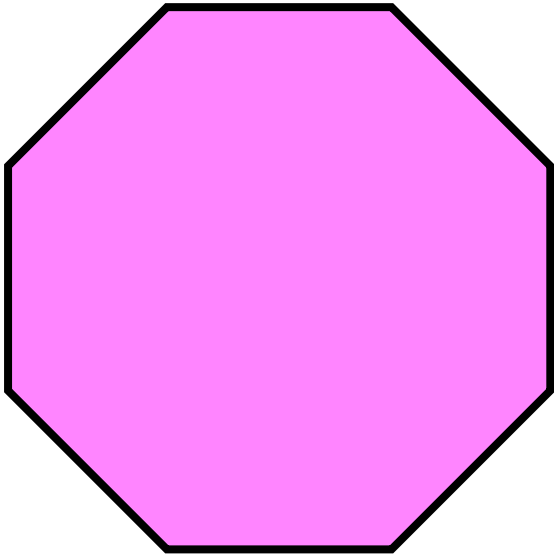

8 sides

oval

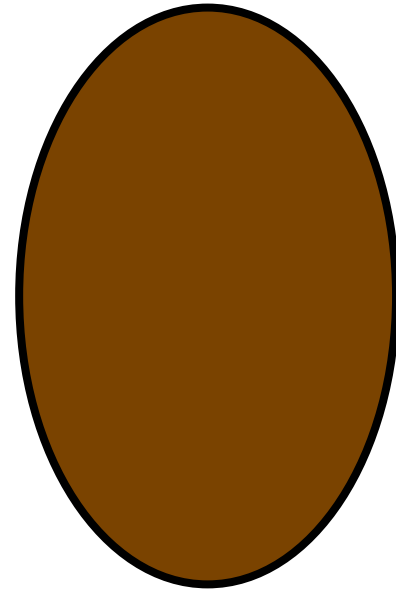

round, stretched out

# Letter P

## Carpet Game

Choose a picture and  
make its sound.

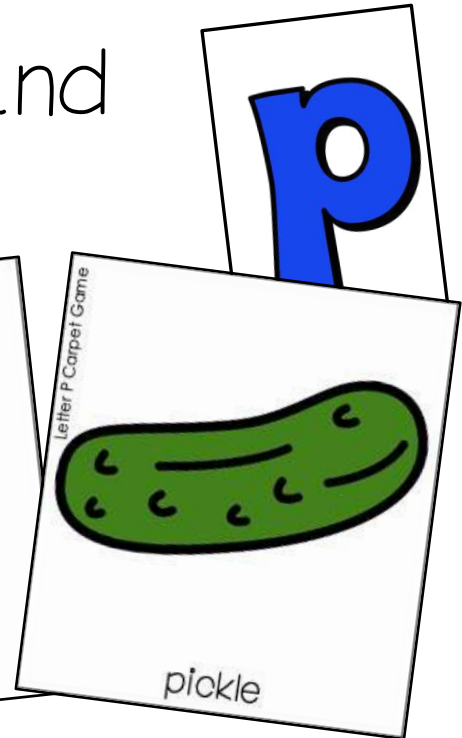
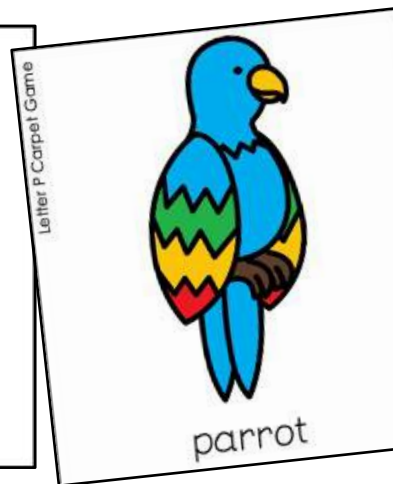
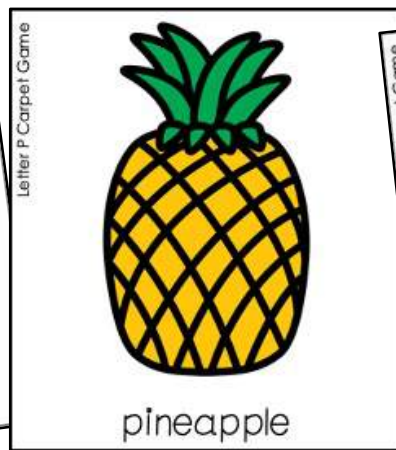
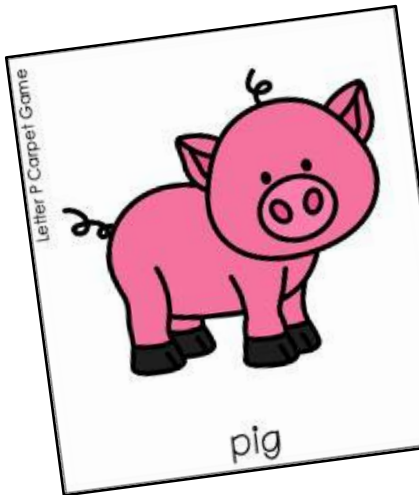

Where will the **letter p**  
be found?

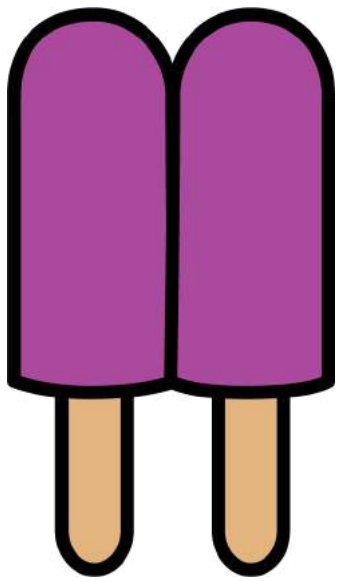

popsicle

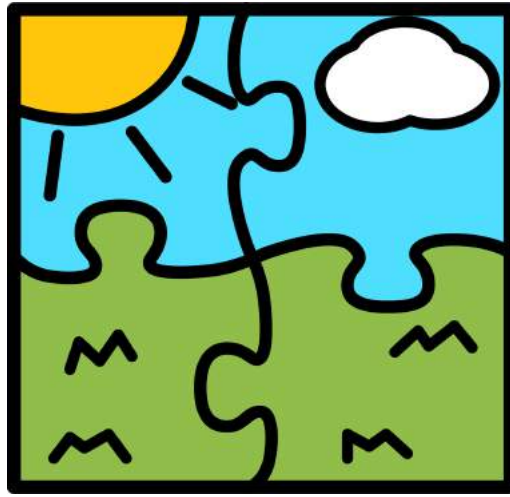

puzzle

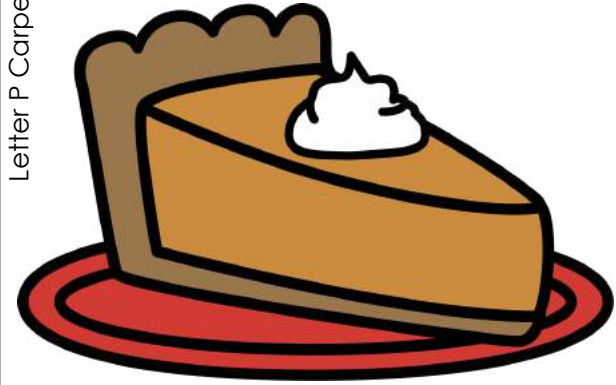

pie

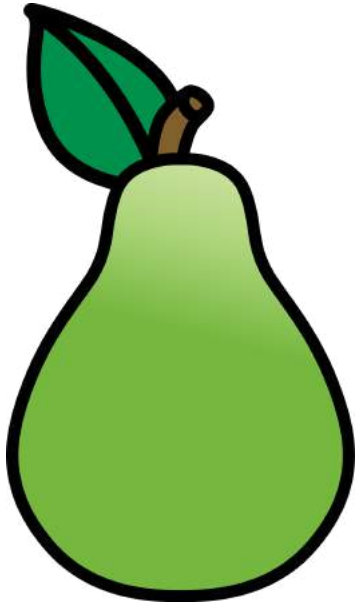

pear



pumpkin



picnic

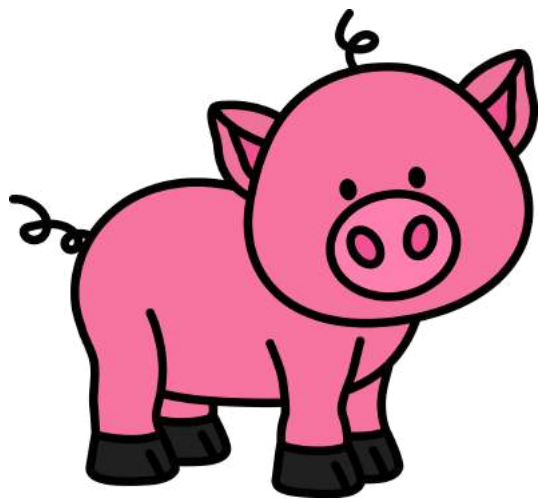

pig

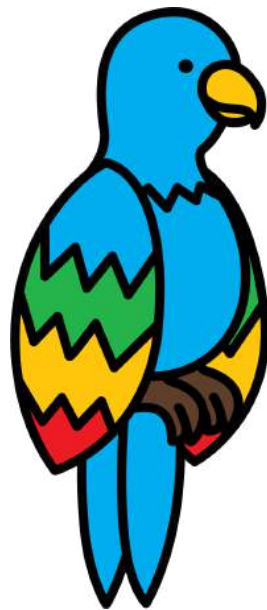

parrot

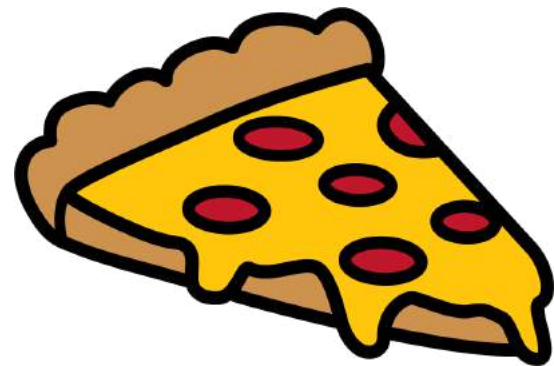

pizza

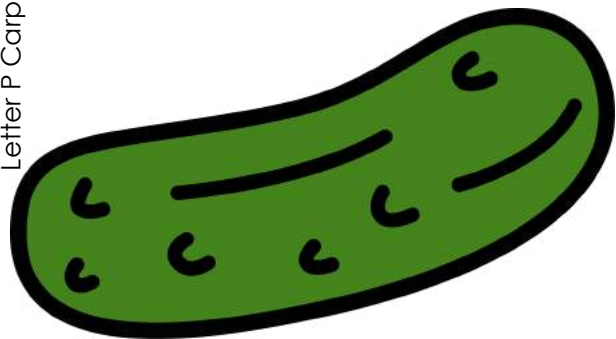

pickle

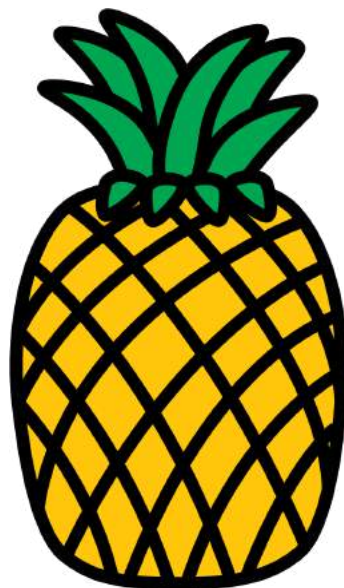

pineapple

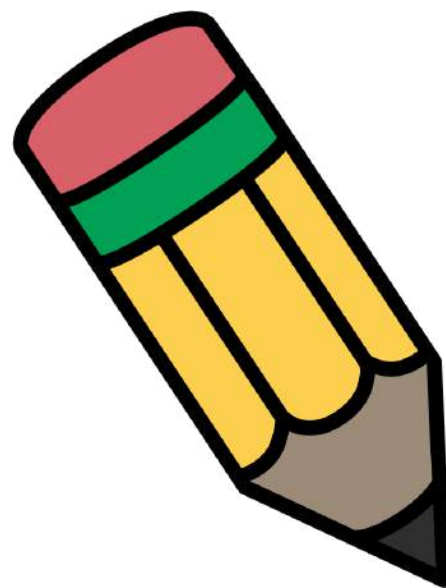

pencil

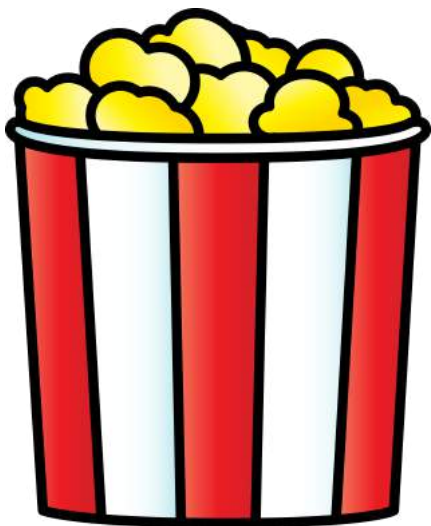

popcorn



police car



pancakes



paint

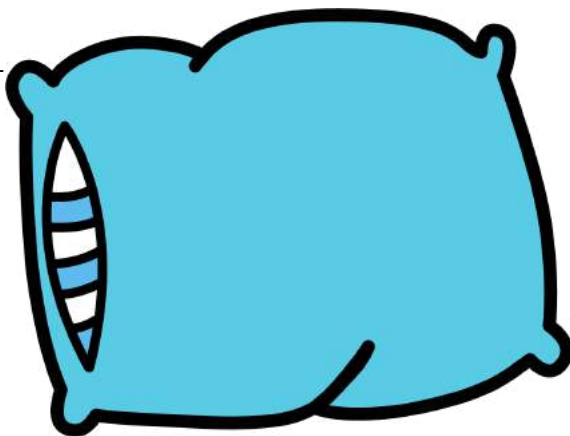

pillow

Cut out the letter p.

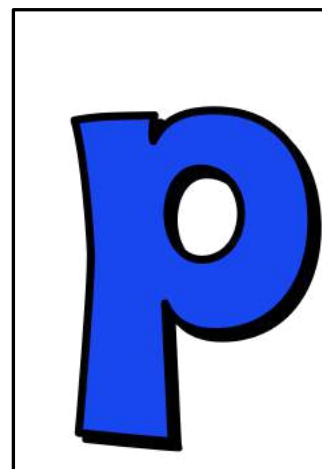

# Face Collage Artwork

Day 9  
Art  
Project

Step  
#1

Gather the materials:

- white drawing paper
- black marker
- old magazines to cut apart

- scissors
- glue stick



Step  
#2

Pass out materials to students. Model how to draw an oval in the center of the page for the

outline of a face.

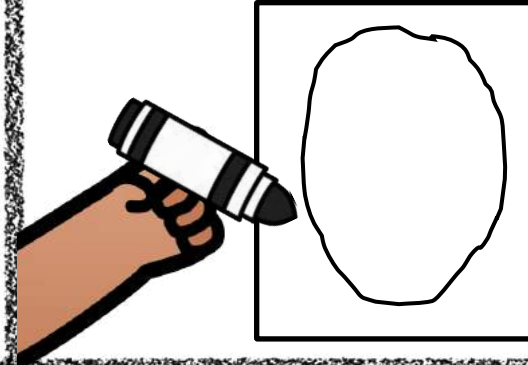

Step  
#3

Allow students to cut pictures out of magazines that show eyes, nose, mouth, ears, etc.



Alternatively, pre-cut pictures and have them available in labeled bins during the project.

Step  
#4

Provide time for students to glue pictures onto their paper to create their own Picasso inspired artwork.

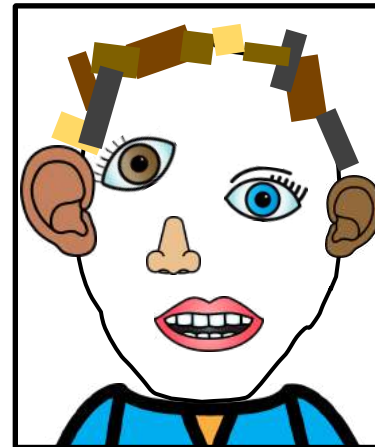

\* Students may choose to color the rest of the face or glue other shapes in the blank space, just like Picasso did!

# Conclusion

## Unit Conclusion

Day 10  
lesson  
plans

Art does not have just one style and anyone can be an artist. All that is needed is a bit of creativity and imagination.

### Objectives:

- The students will draw and imitate the act of writing.
- The students will count sets to 5 and make combinations of objects to create each set.

### Activities:

1. Ask the students which artist is their favorite. Students can draw a picture or teachers can transcribe their responses on the attached recording sheets.
2. Recite the “5 Busy Artists” chip clip poem. Start by having the 5 artist pictures attached to a large piece of drawing paper or easel. Remove an artist after each verse.
3. Teach the ASL signs for each color using the included posters.



### Literacy Extension:

Read “Luna Loves Art” by Joseph Coelho.

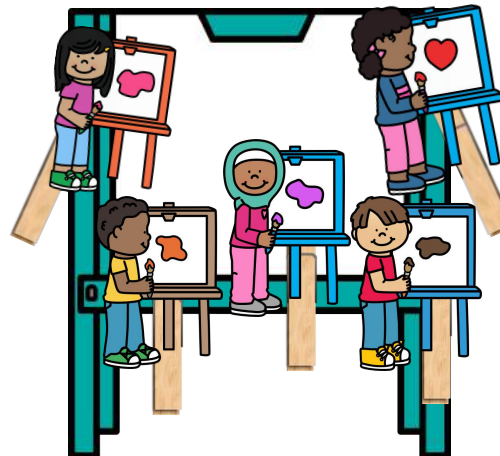

Our favorite

Artists



My favorite artist is:

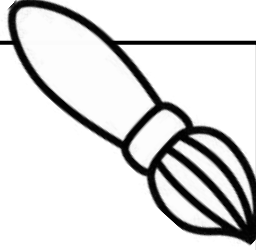
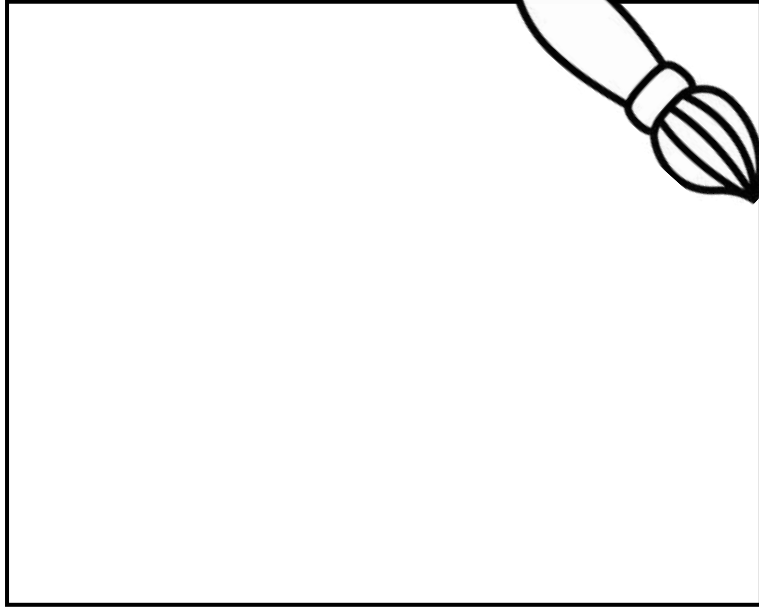

Name:

My favorite artist is:

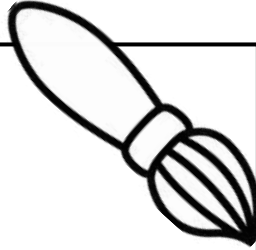
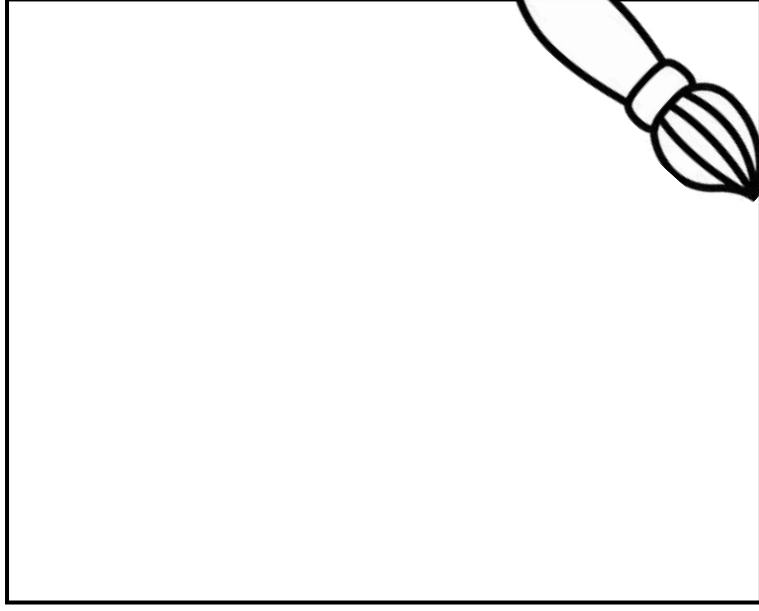

Name:

My favorite artist is:

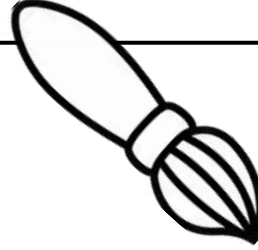
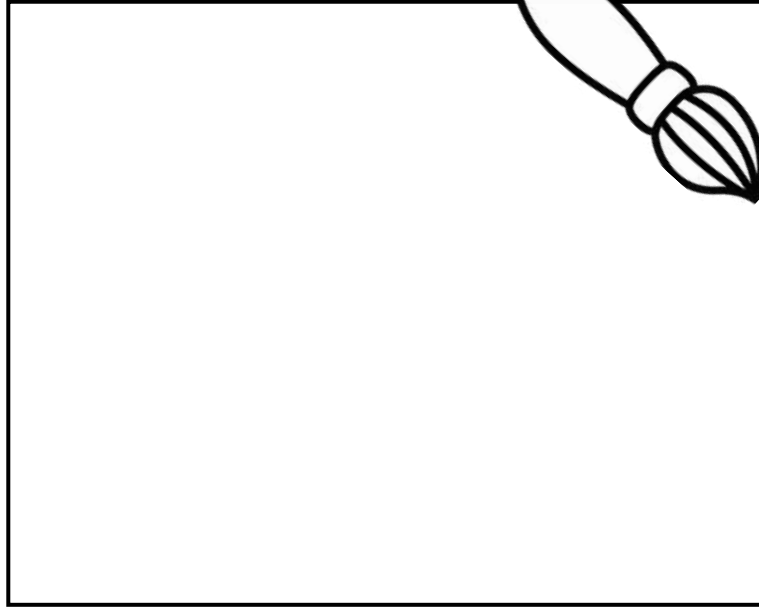

Name:

My favorite artist is:

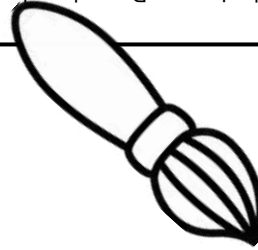
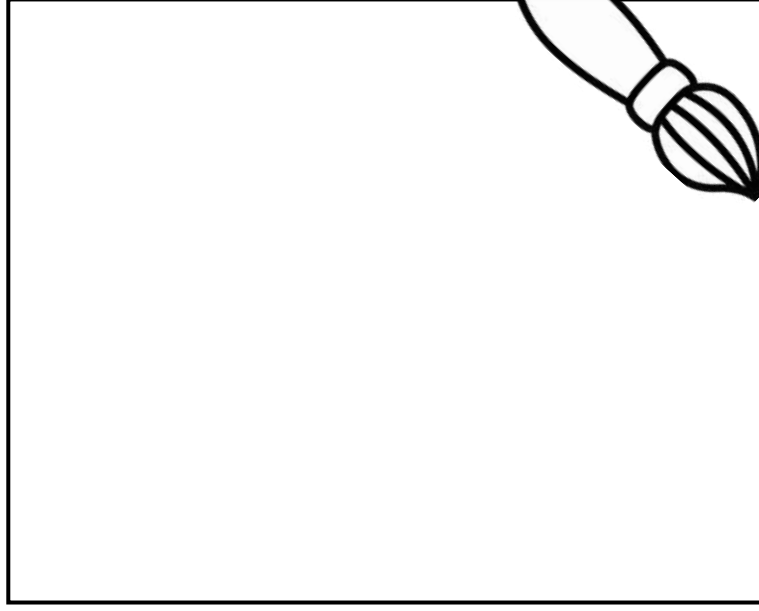

Name:

# 5 Busy Artists

## Chip Clip Poem

Five busy artists,  
Painting red, blue, and green.

One walks away,  
How many can be seen?

Four busy artists,  
Painting red, blue, and green.

One walks away,  
How many can be seen?

**Continue counting backwards.**

The artists have finished.

We knew they could!

They painted and painted,

It all looks so good!



Busy Artists Poem

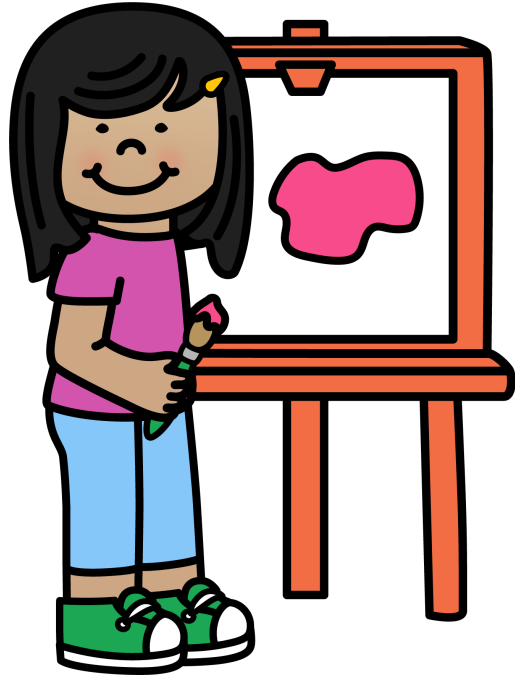

Busy Artists Poem

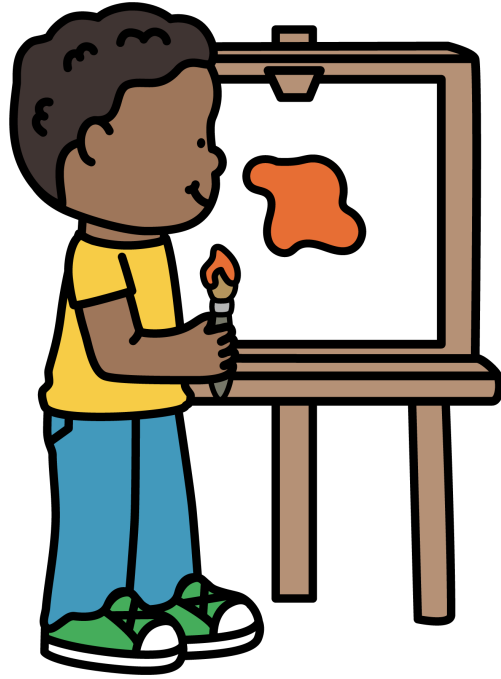

Busy Artists Poem

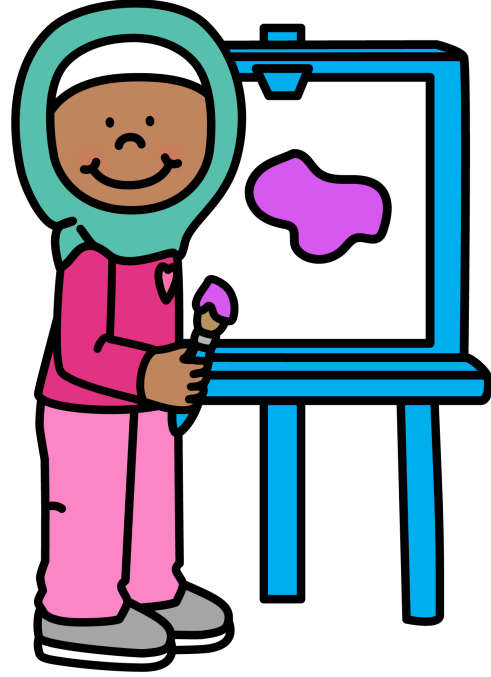

Busy Artists Poem

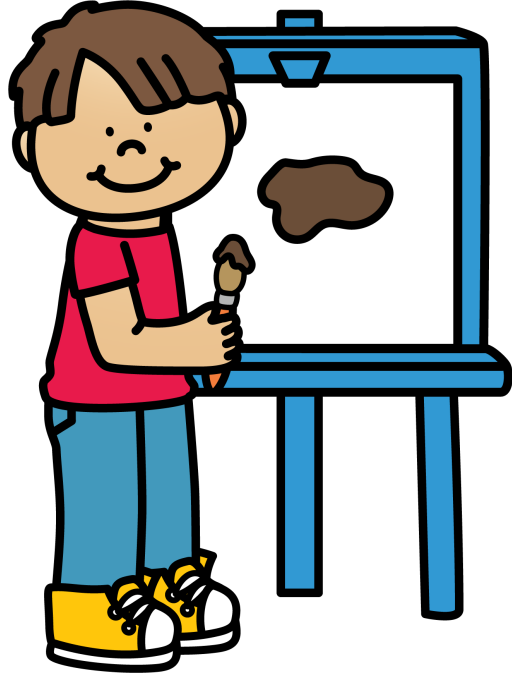

Busy Artists Poem

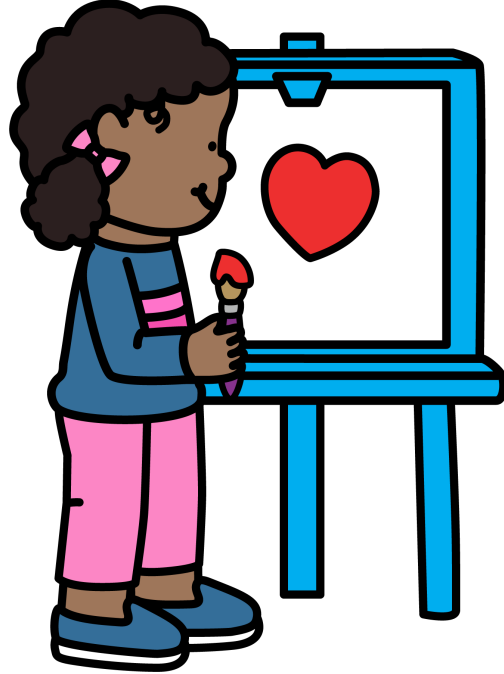

Busy Artists Poem

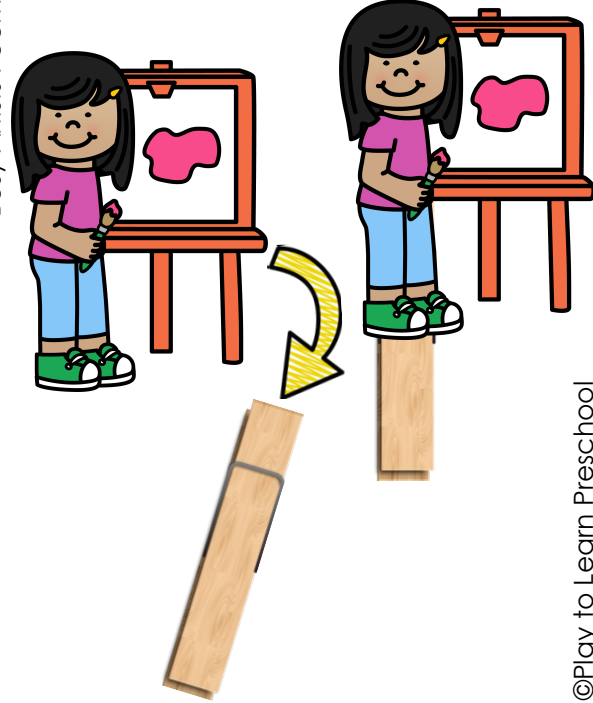



red

Using the index finger on bottom lip, move finger down to the tip of the chin.



orange

Cup hand in front of mouth, then squeeze hand together twice.



yellow

Extend thumb and pinkie finger to make a Y, then wiggle back & forth.

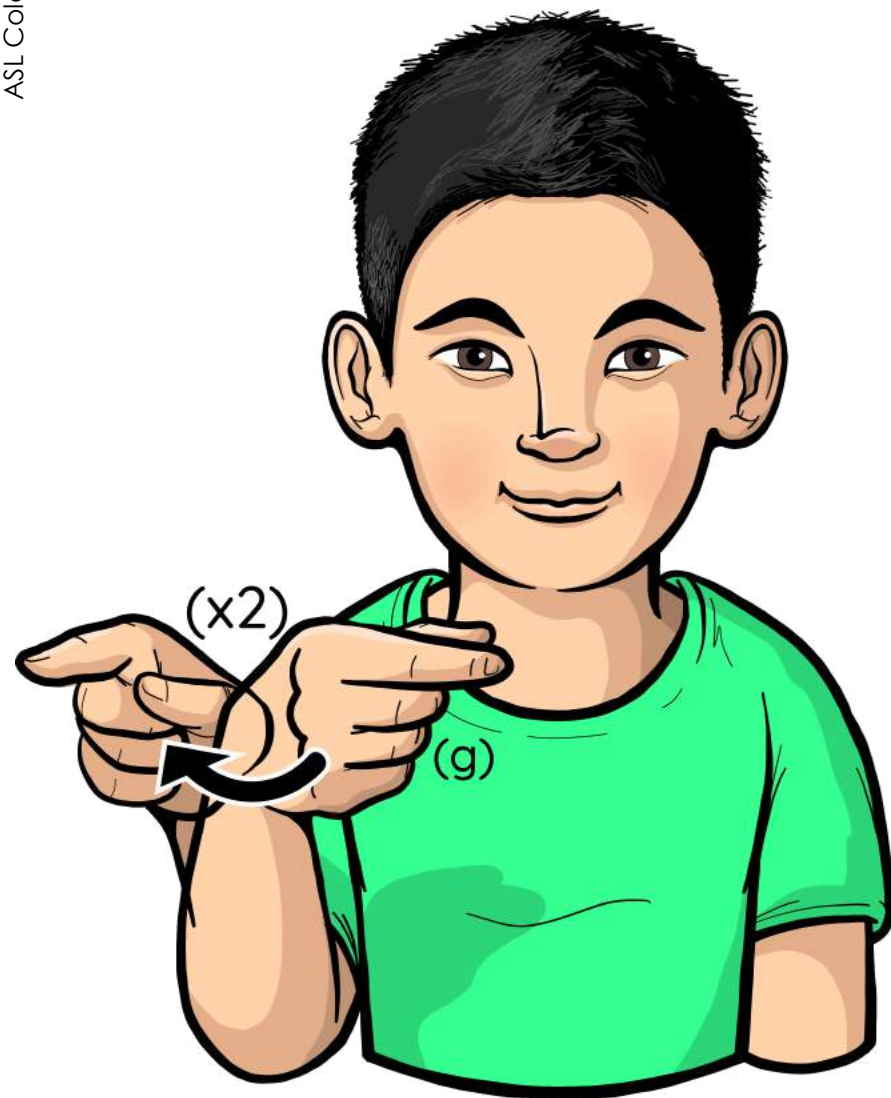

green

Extend index finger and thumb to make an ASL "g", then wiggle back & forth.

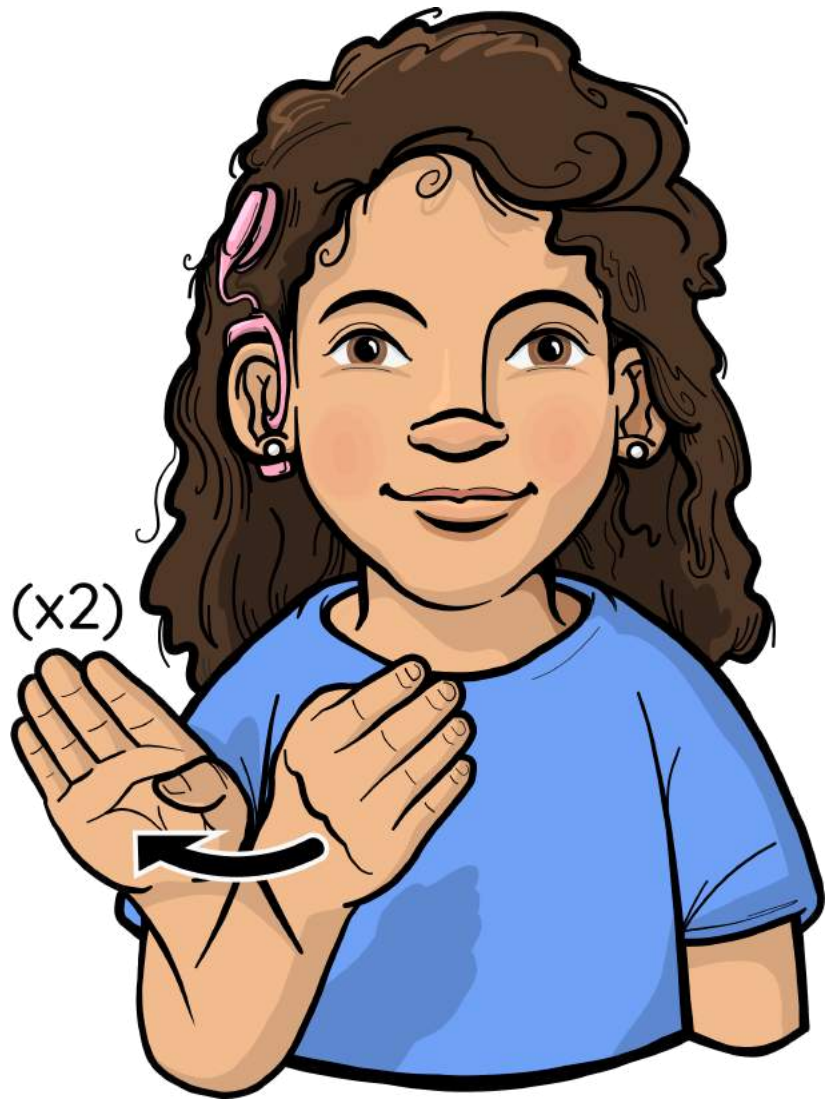

blue

Open hand, facing away from you, and tuck in thumb. Wave back & forth.

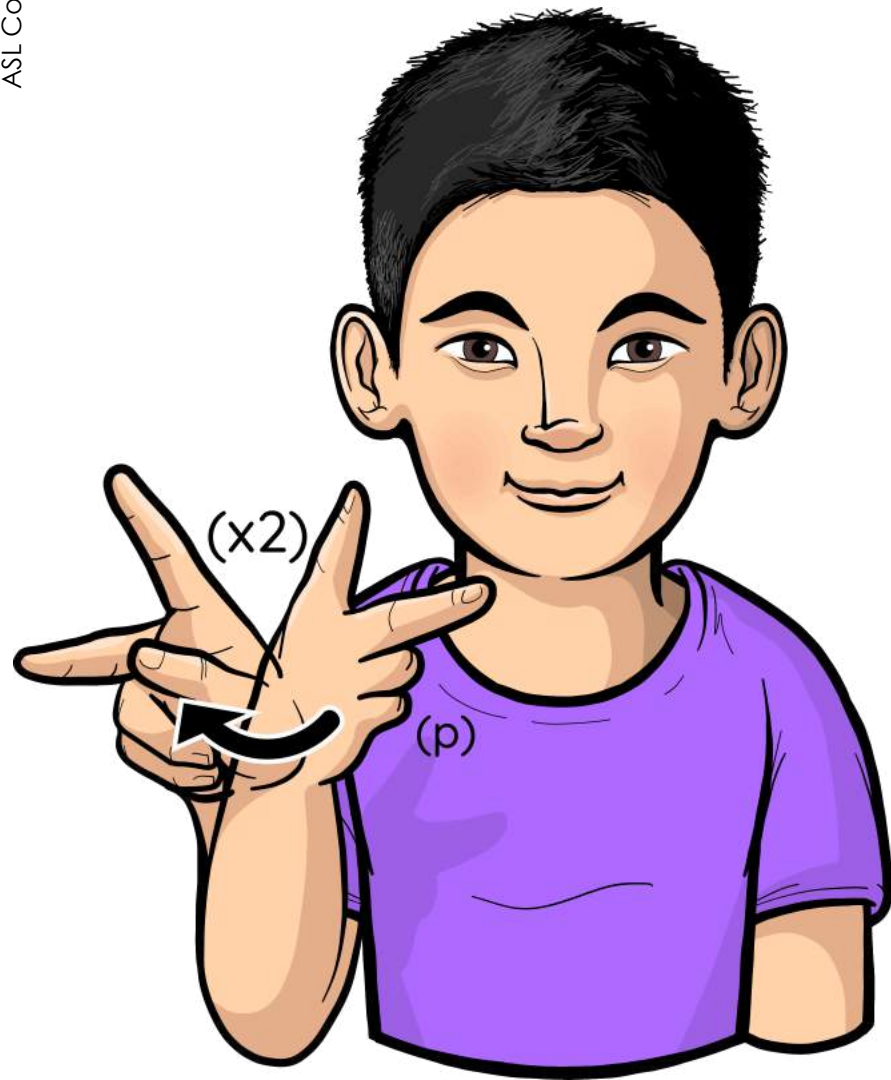

purple

Extend index and middle fingers to make an ASL "p", then wiggle back & forth.

# Claude Monet

## Free Lesson

Free  
Bonus  
Lesson

Claude Monet was born in Paris, France, Nov. 14, 1840. As a child, Monet liked to draw pictures of people and sell them. He had a pond in his garden and would spend a lot of time there painting.

## Objectives:

- The students will identify numbers.
- The students will use fine motor skills to produce works of art.

## Activities:

1. Introduce Claude Monet by showing some of his famous paintings like *Water Lilies*.
2. Play the "Silly Artist" carpet game.
  - Line up the pictures of the paint palettes. Pick the right number of cards for your students. Identify the numbers together.
  - Hide the paint brush under one of the palettes and recite the poem to find it.
  - Children guess where the paint brush is hiding by identifying the number or the item.
3. Follow the steps to create a Claude Monet inspired water color masterpiece.

**Claude Monet**  
Nov. 14, 1840  
Dec. 5, 1926

**Biography**  
Claude Monet was born in Paris, France, Nov. 14, 1840. He lived with his mother and father and went to Le Havre School of Arts. As a child, Monet liked to draw pictures of people and would sell them. In 1859, he met an artist named Eugene Boudin, who encouraged him to paint landscapes with oil paints. During his first exhibit, Monet displayed his painting *Impression, Sunrise*, which coined the term "Impressionism."  
Water Lilies is one of Monet's most famous paintings. He had a pond in his garden and would spend a lot of time there painting. He painted the water lilies at different times of the day for different effects. This painting inspired many other artists.

**Famous Works**

- *Impression, Sunrise* - 1872
- *The Japanese Footbridge* - 1899
- *Water Lilies* - 1906

**Fun Facts**

- Claude Monet started drawing caricatures of people when he was a child.
- Monet often wore a beret, which is a type of hat. He thought it made him look more artistic.

**Famous Quote:**  
"I perhaps owe having become a painter to flowers."

See for more information



**Water Lilies**  
Art Project

**Step 1:** Gather the materials:  
• 6x10 canvas for each student  
• water colors - blue, green, and turquoise  
• clear glue  
• small green tissue paper  
• pink and purple tissue paper

**Step 2:** Students paint an 6x10 picture with blue, green, and turquoise water colors. For a fish color, do not dilute the water colors.

**Step 3:** Next, while the water colors are still wet, students artize clear glue on the canvas. The glue will react with the water colors for a beautiful effect.

**Step 4:** Finally, students add the small green tissue paper and tissue paper torn and crumpled into flowers to make beautiful water lilies.

### Extension Idea:

Read *Monet's Cat* by Lily Murray.

# Claude Monet

Oil  
Painting

## Biography

Nov. 14, 1840

Dec. 5, 1926

Claude Monet was born in Paris, France, Nov. 14, 1840. He lived with his mother and father and went to Le Harve School of Arts. As a child, Monet liked to draw pictures of people and would sell them. In 1858, he met an artist named Eugene Boudin, who encouraged him to paint landscapes with oil paints.

During his first exhibit, Monet displayed his painting *Impression, Sunrise*, which coined the term "Impressionism."

*Water Lilies* is one of Monet's most famous paintings. He had a pond in his garden and would spend a lot of time there painting. He painted the water lilies at different times of the day for different effects. This painting inspired many other artists.

## Famous Works:

- [Impression, Sunrise](#) - 1872
- [The Japanese Footbridge](#) - 1899
- [Water Lilies](#) - 1906

## Fun Facts:

- Claude Monet started drawing caricatures of people when he was a child.
- Monet often wore a beret, which is a type of hat. He thought it made him look more artistic.

## Famous Quote:

"I perhaps owe having become a painter to flowers."

Scan for more information

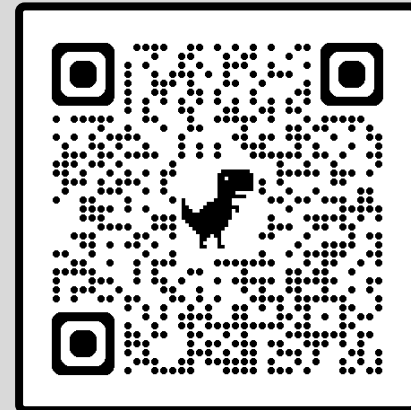

[https://kids.kiddle.co/  
Claude\\_Monet](https://kids.kiddle.co/Claude_Monet)

# Silly Artist

Silly little artist,  
In such a rush.



Pick a number.  
To find your brush!

Silly Artist



1

Silly Artist



2

Silly Artist



3

Silly Artist



4

Silly Artist



5

Silly Artist



6

Silly Artist



7

Silly Artist



8

Silly Artist



9

Silly Artist



10

Silly Artist



11

Silly Artist



12

Silly Artist



13

Silly Artist



14

Silly Artist



15

Silly Artist



16

Silly Artist



17

Silly Artist



18



19



20

©Play to Learn Preschool

Cut out the paint brush.

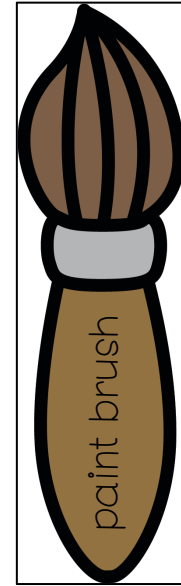

# Water Lilies

## Art Project

Step #1

Gather the materials:

- 8"x10" canvas for each student
- water colors – blue, green, and turquoise
- clear glue
- small green cupcake liners
- pink and purple tissue paper

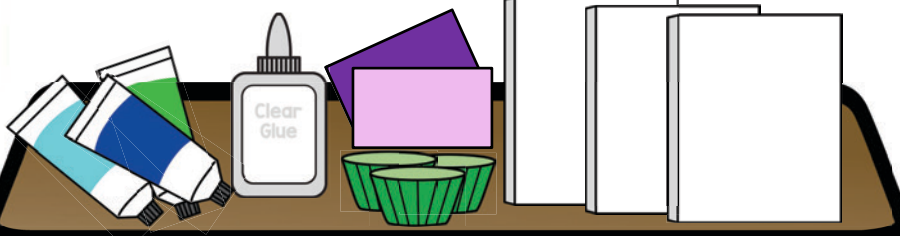

Step #2

Students paint the canvas with blue, green, and turquoise water colors. For a richer color, do not dilute the water colors.

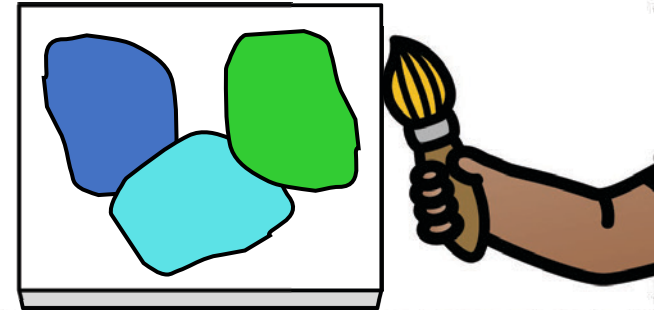

Step #3

Next, while the water colors are still wet, students drizzle clear glue on the canvas. The glue will react with the water colors for a beautiful effect.



Step #4

Finally, students add the small green cupcake liners and tissue paper torn and crumpled into flowers to make beautiful water lilies.

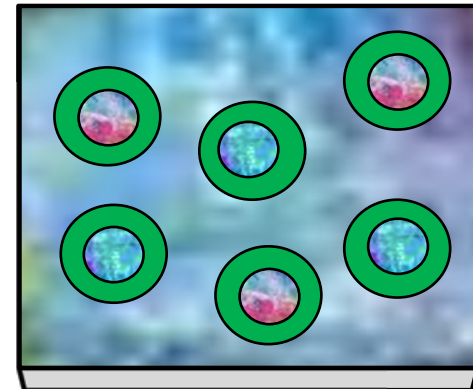

# Center Activities

# Centers

- Line Tracing
- Initial Sounds
- Visual Discrimination
- Count & Clip Cards
- Color Matching
- Shape Sorting
- Concentration
- Cutting Practice
- Picture Puzzles
- Journaling

### Line Tracing

**Objective:** The students will understand the purpose of writing.  
**Preparation:** Print and laminate these tracing cards. Another option is to place them inside a plastic sleeve. Provide dry erase markers. (Glue a pom-pom onto the lid of the marker for the students to use as an eraser!)

### Initial Sounds

**Objective:** The students will draw and imitate the act of writing.  
**Preparation:** Copy each page and place it into a plastic sleeve.  
**Procedure:** Students use a dry erase marker to write the initial letter of each word.

### Visual Discrimination

**Objective:** The students will use visual discrimination skills to match the items.  
**Preparation:** Copy the picture cards. Glue the large pictures (first 2 pages) into a file folder. Cut and laminate the smaller pictures.  
**Procedure:** Students place matching pictures together.

### Count and Clip Cards

**Objective:** Students will practice one-to-one correspondence and number recognition to 10.  
**Preparation:** Print the cards, mat, out a part, and laminate as desired.  
**Procedure:** Students count the pictures on each card and mark the correct answer with a clothes pin.

### Color Matching

**Objective:** The students will match items by color.  
**Preparation:** Print, mat, out out, and laminate the pictures. Place large pictures face up on the table and small pictures in an envelope or bag. (Alternatively, create an interactive bulletin board using hook and latch tape or magnets.)

### Shape Sorting

**Objective:** The students will sort objects by property.  
**Preparation:** Print, out out, and laminate all pieces.  
**Procedure:** Students choose a picture and match it to the corresponding shape.

### Cutting Practice

**Objective:** The students will coordinate eye-hand movement and control the small muscles in their hands.  
**Preparation:** Print a cutting page for each student. Demonstrate proper scissors usage and guide students to cut along the lines from the bottom to the top.  
**Procedure:** The students will cut along the dotted lines from the bottom of the page to the top.

### Picture Puzzles

**Objective:** The students use hand-eye coordination and fine motor skills to assemble a puzzle.  
**Preparation:** Copy each page, mat, out, and laminate as desired.  
**Procedure:** Students match the puzzle pieces together.

### Journaling

**Objective:** The students will understand the purpose of writing.  
**Procedure:** Print the journal sheets. Students can use the journal prompts to write and draw a picture. The words can also be written for the student if necessary.

### Concentration

**Objective:** The students will use visual discrimination (matching) skills to identify two identical objects.  
**Preparation:** Print the picture cards and mat onto cardstock. Cut apart and laminate as desired.  
**Procedure:** Place the cards face down. Students take turns flipping over 2 cards at a time. If the cards match, the student gets to keep the pair. If they don't match, they return them to the face-down position and try again.

# Line Tracing

**Objective:** The students will understand the purpose of writing.

**Preparation:** Print and laminate these tracing cards. Another option is to place them inside a plastic sleeve. Provide dry erase markers. (Glue a pom-pom onto the lid of the marker for the students to use as an eraser!)

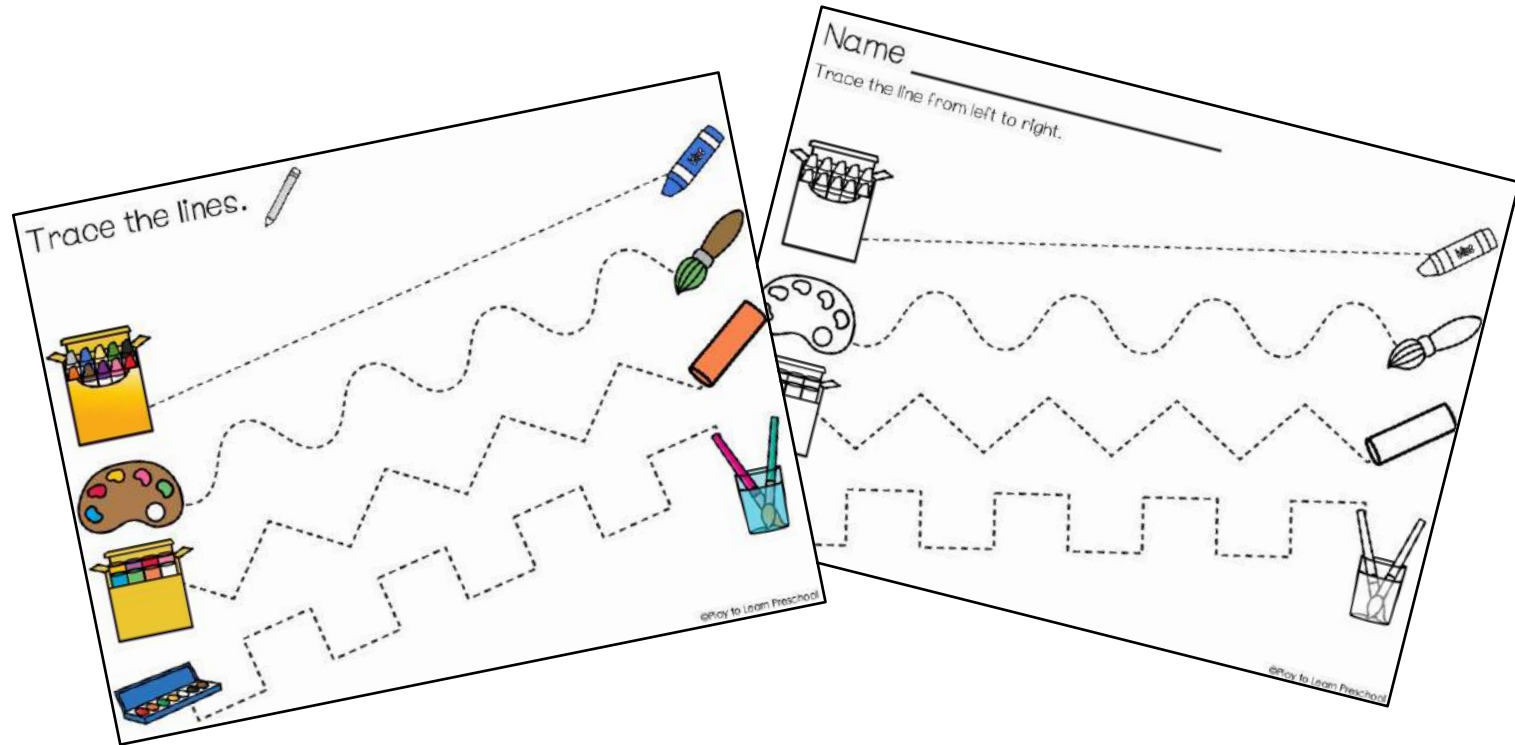

**Procedure:** The students will trace the dotted lines from left to right to practice fine motor skills.

Trace the lines.



Tracing practice activity with four rows, each featuring a child on the left, a dashed line, and an easel on the right.

- Row 1:** A girl with a paint palette and brush on the left. A straight dashed line connects her to an easel on the right displaying a yellow sun.
- Row 2:** A boy with a paintbrush on the left. A wavy dashed line connects him to an easel on the right displaying a rainbow.
- Row 3:** A girl with a paintbrush on the left. A zigzag dashed line connects her to an easel on the right displaying a red heart.
- Row 4:** A boy with a paint palette and brush on the left. A curved dashed line connects him to an easel on the right displaying a green tree.

Trace the lines.



Trace the lines.

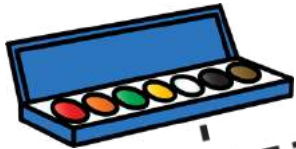
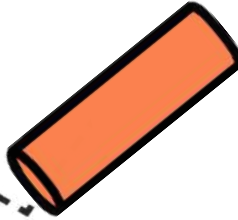
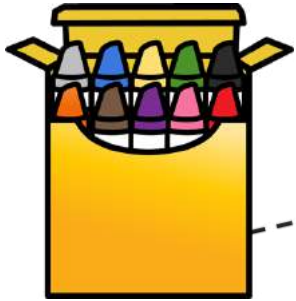
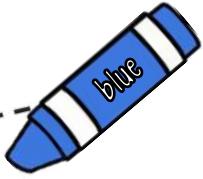

Name \_\_\_\_\_

Trace the line from left to right.

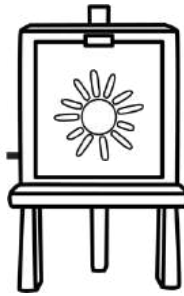

Name \_\_\_\_\_

Trace the line from left to right.

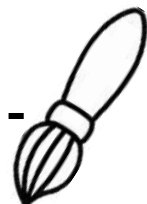
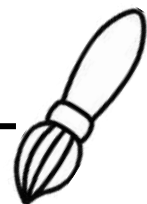
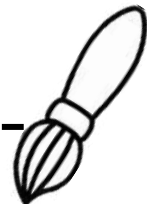

Name \_\_\_\_\_

Trace the line from left to right.

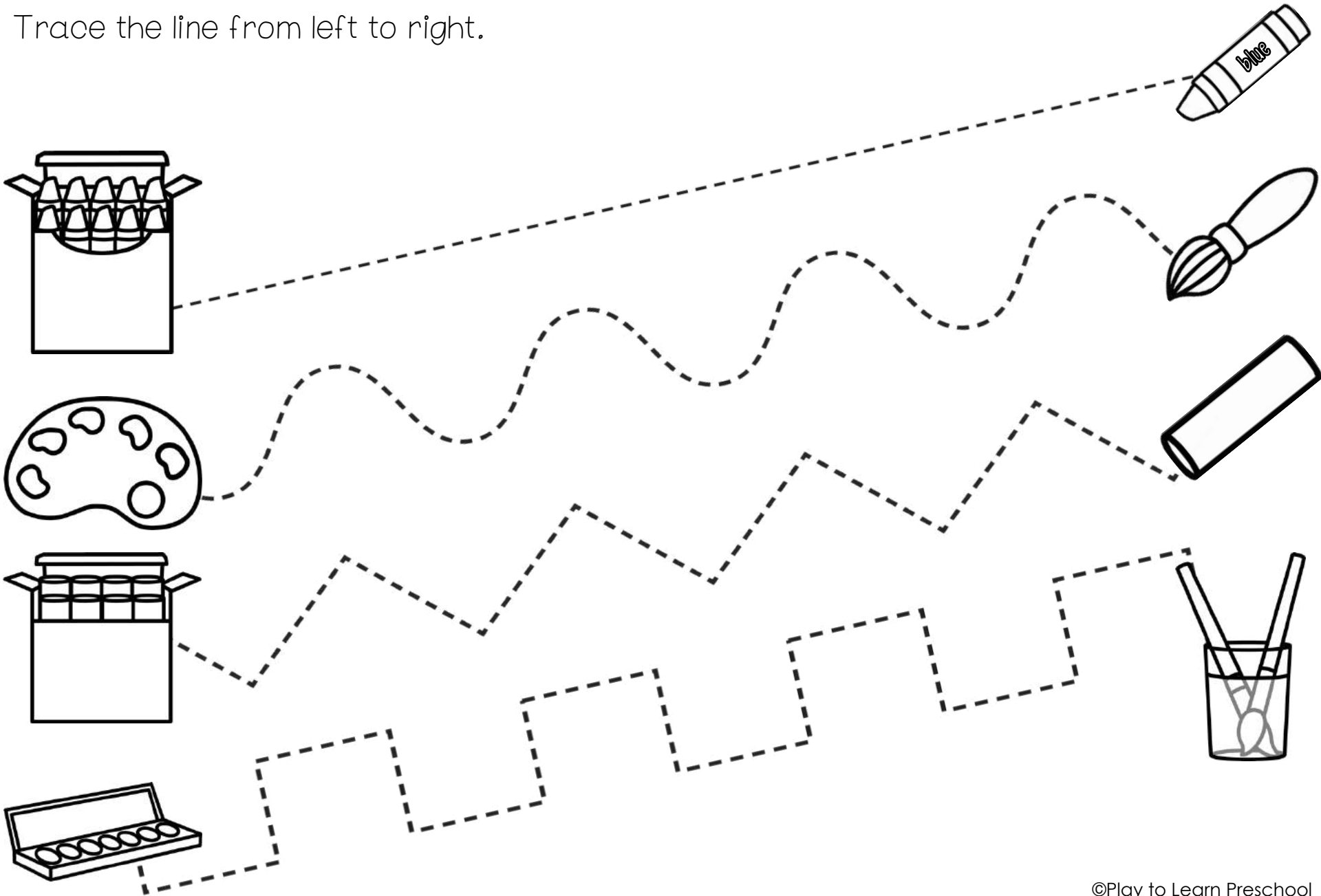

# Initial Sounds

## Writing Practice

**Objective:** The students will draw and imitate the act of writing.  
**Preparation:** Copy each page and place it into a plastic sleeve.  
**Procedure:** Students use a dry erase marker to trace the first letter of each word.

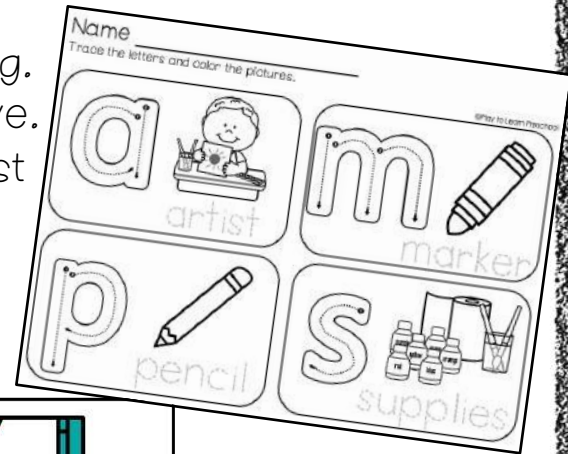

a  
artist

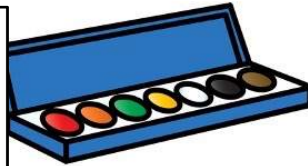

w  
atercolors



p  
encil

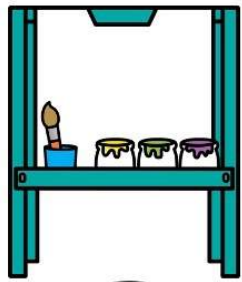

e  
asel

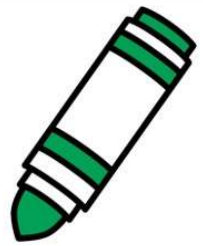

m  
arker

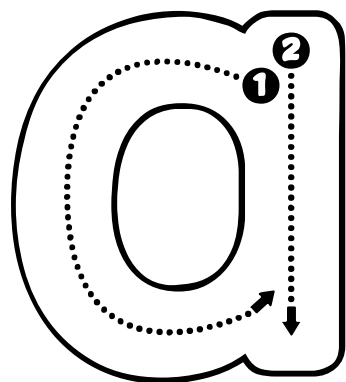

artist

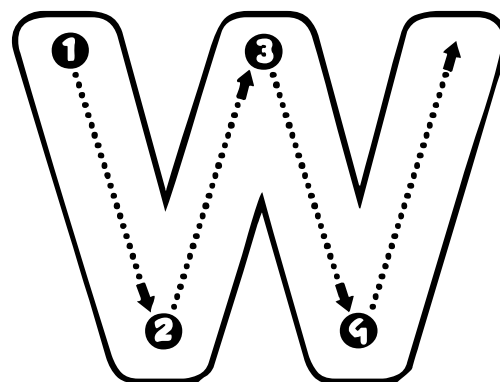
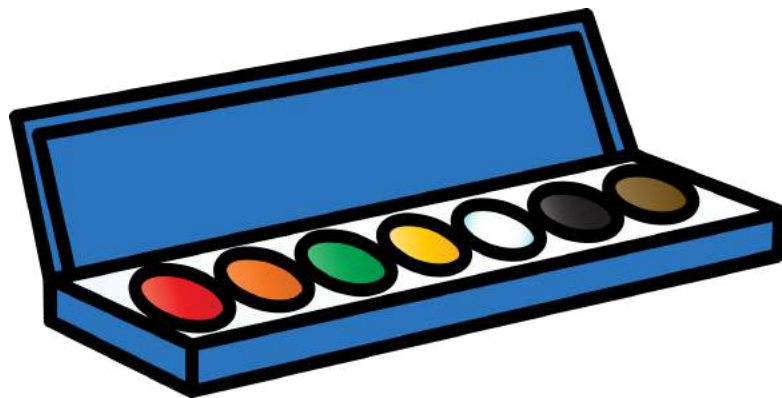

watercolors

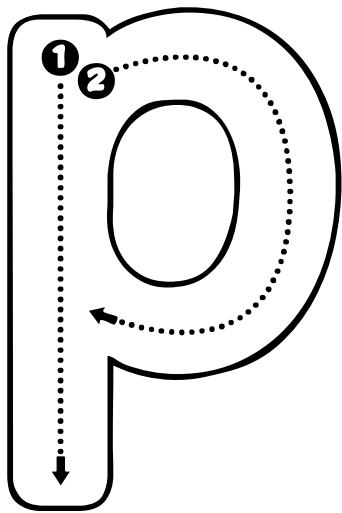
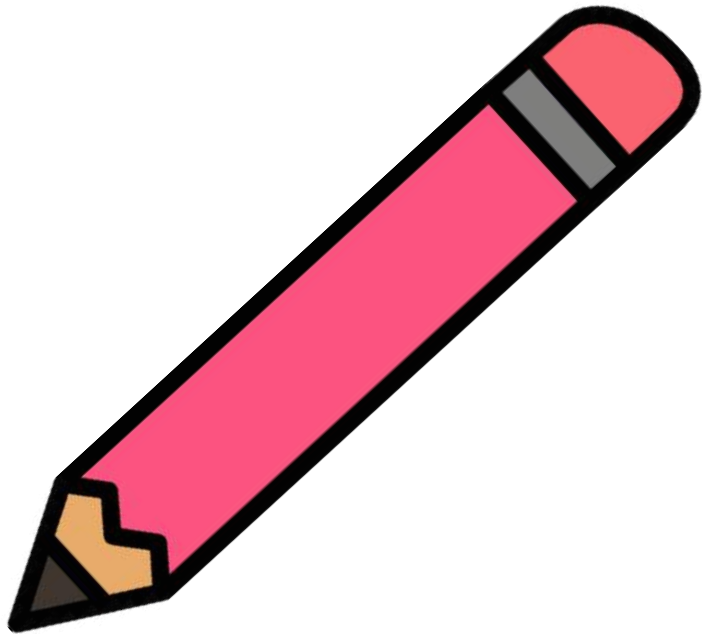

pencil

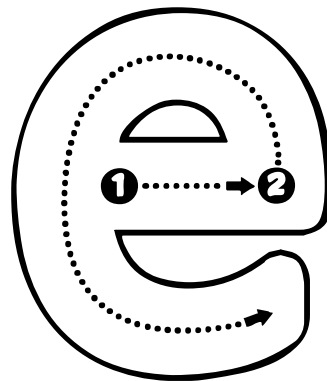
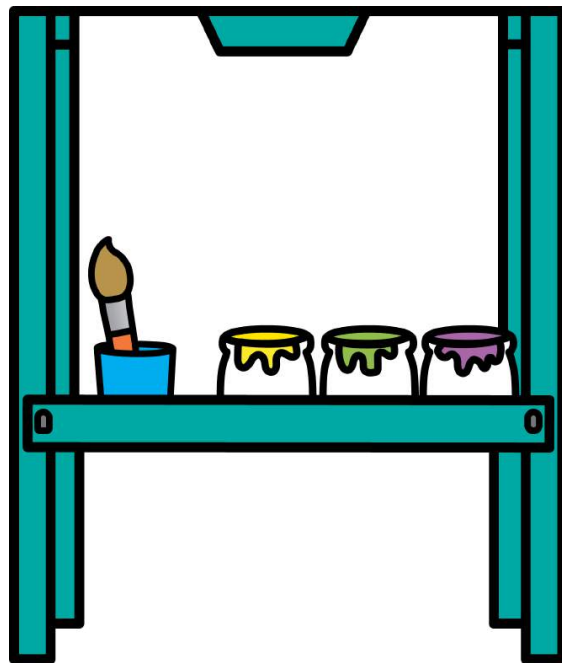

easel

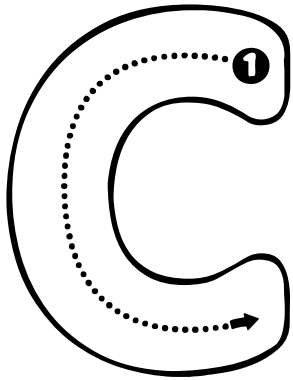

color

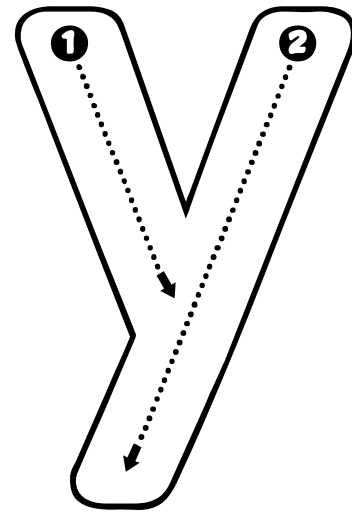

yellow

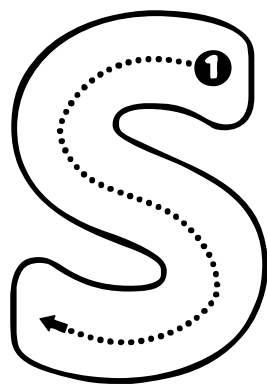
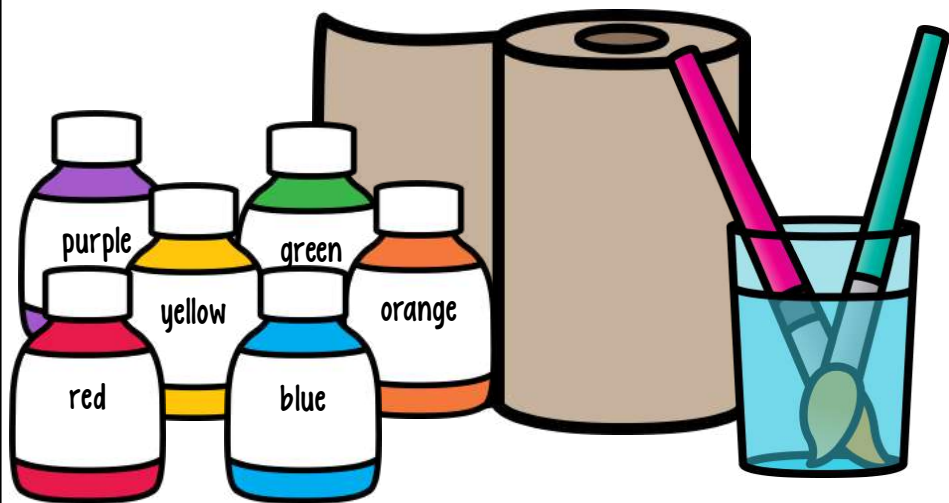

supplies

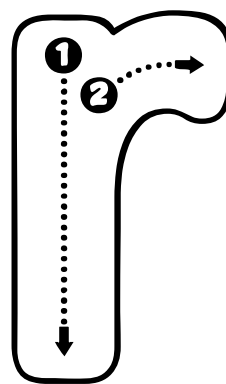
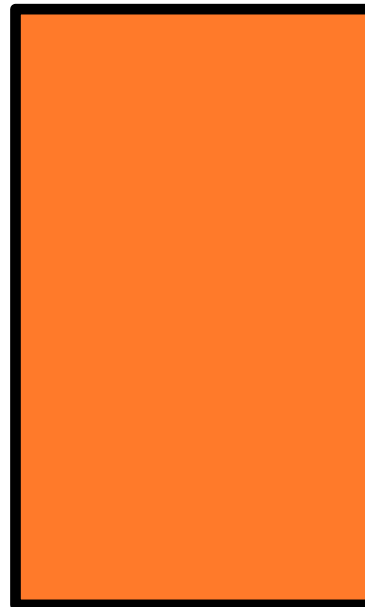

rectangle

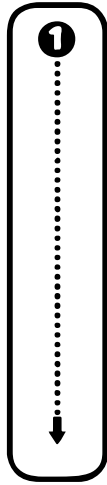
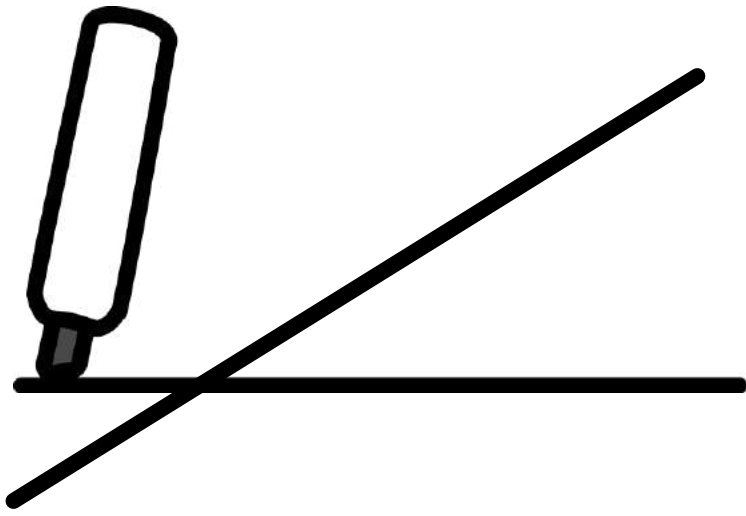

lines

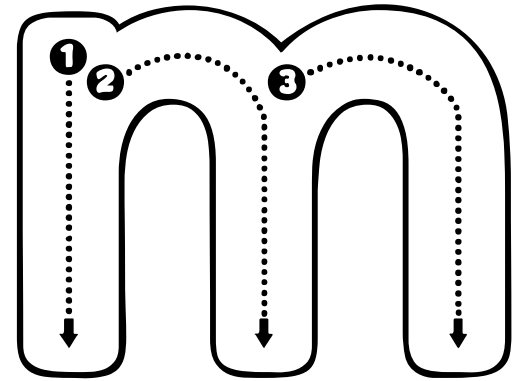
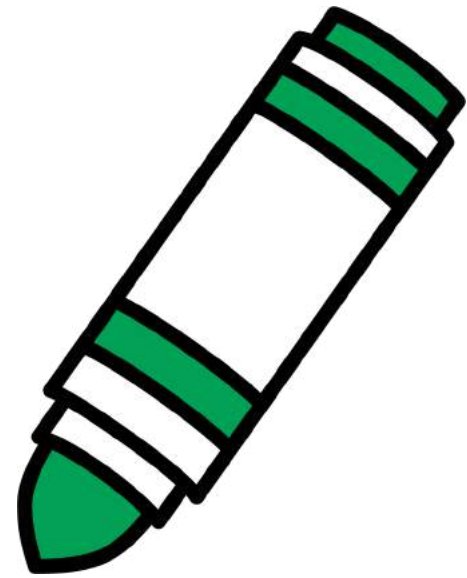

marker

Name \_\_\_\_\_

Trace the letters and color the pictures.

©Play to Learn Preschool

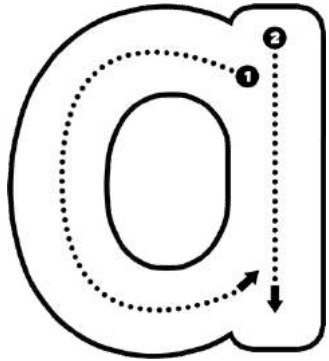

artist

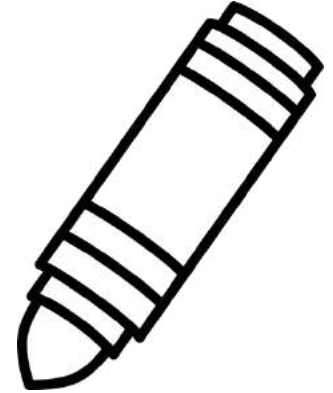
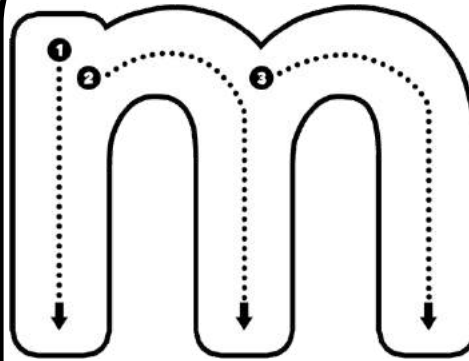

marker

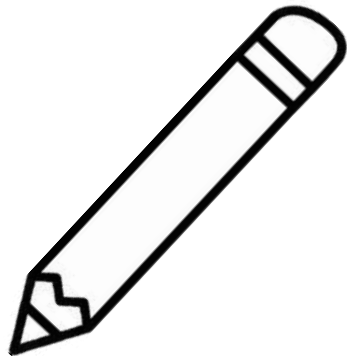
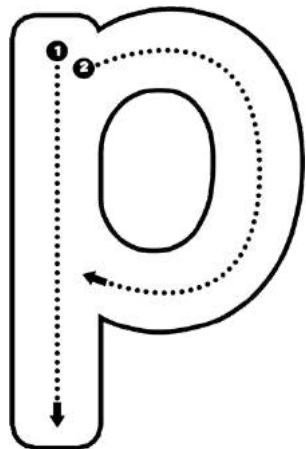

pencil

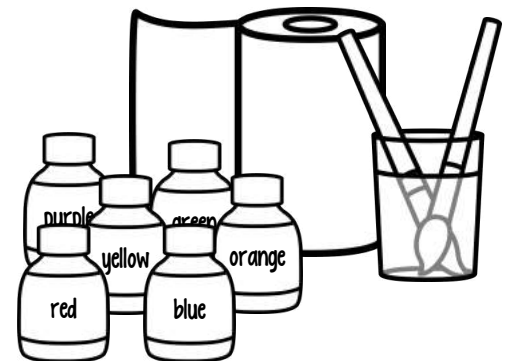

supplies

# Visual Discrimination

## File Folder Game

**Objective:** The students will use visual discrimination skills to match the items.

**Preparation:** Copy the picture cards. Glue the large pictures (first 2 pages) inside a file folder. Cut and laminate the smaller pictures.

**Procedure:** Students place matching pictures together.

## Visual Discrimination



## Visual Discrimination



# Artist



**Visual Discrimination**

Artist Visual Discrimination

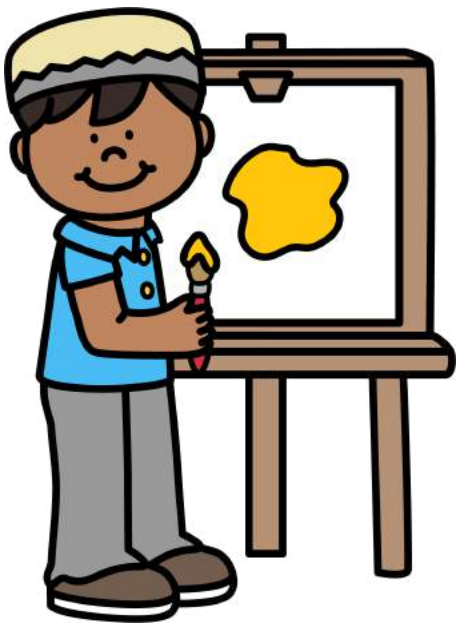

George

Artist Visual Discrimination



Meredith

Artist Visual Discrimination



Izzie

Artist Visual Discrimination



Christina

Artist Visual Discrimination



Preston

Artist Visual Discrimination



Derek

Artist Visual Discrimination

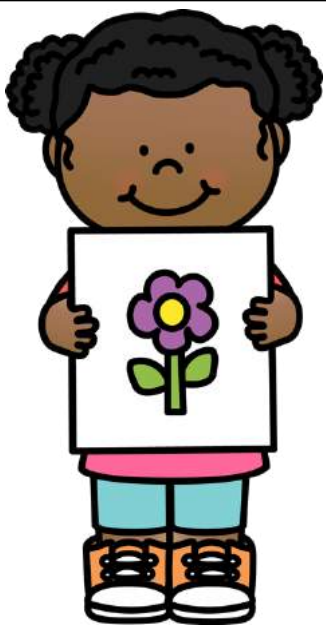

Miranda

Artist Visual Discrimination



Alex

Artist Visual Discrimination



Lexi

Artist Visual Discrimination



Mark

Artist Visual Discrimination



Jackson

Artist Visual Discrimination



Amelia

Artist Visual Discrimination

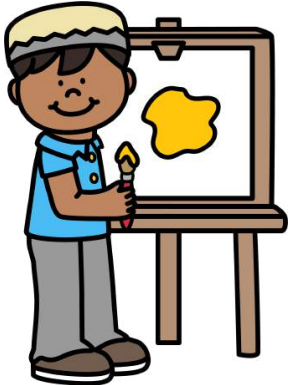

George

Artist Visual Discrimination



Meredith

Artist Visual Discrimination



Izzie

Artist Visual Discrimination



Christina

Artist Visual Discrimination

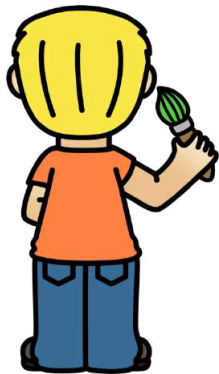

Preston

Artist Visual Discrimination



Derek

Artist Visual Discrimination

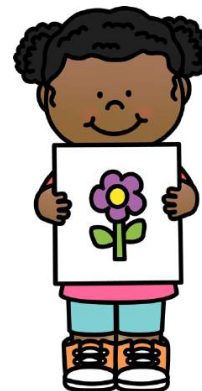

Miranda

Artist Visual Discrimination



Alex

Artist Visual Discrimination



Lexi

Artist Visual Discrimination



Mark

Artist Visual Discrimination



Jackson

Artist Visual Discrimination



Amelia

# Count and Clip Cards

**Objective:** Students will practice one-to-one correspondence and number recognition to 12.

**Preparation:** Print the cards, mat, cut apart, and laminate as desired.

**Procedure:** Students count the pictures on each card and mark the correct answer with a clothes pin.

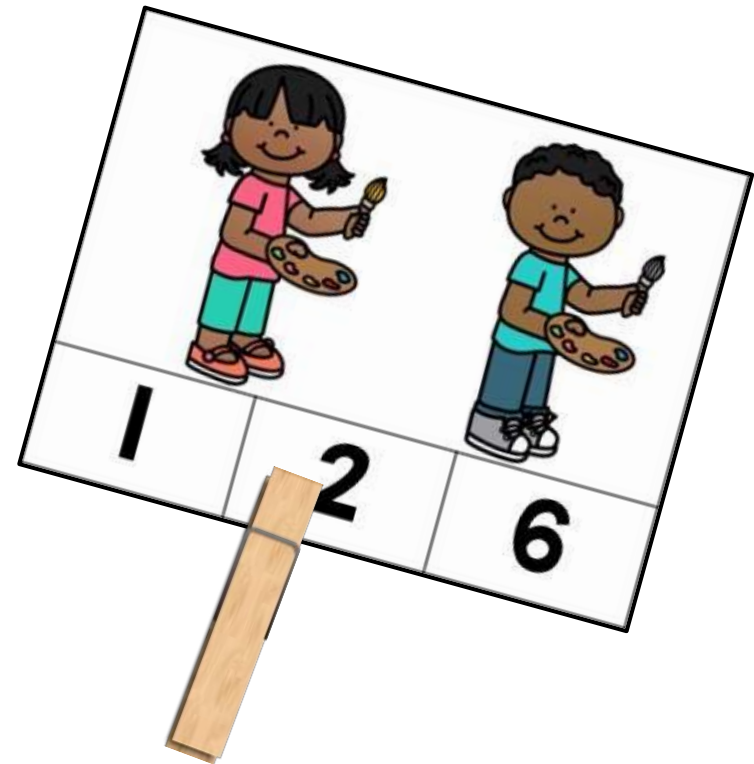
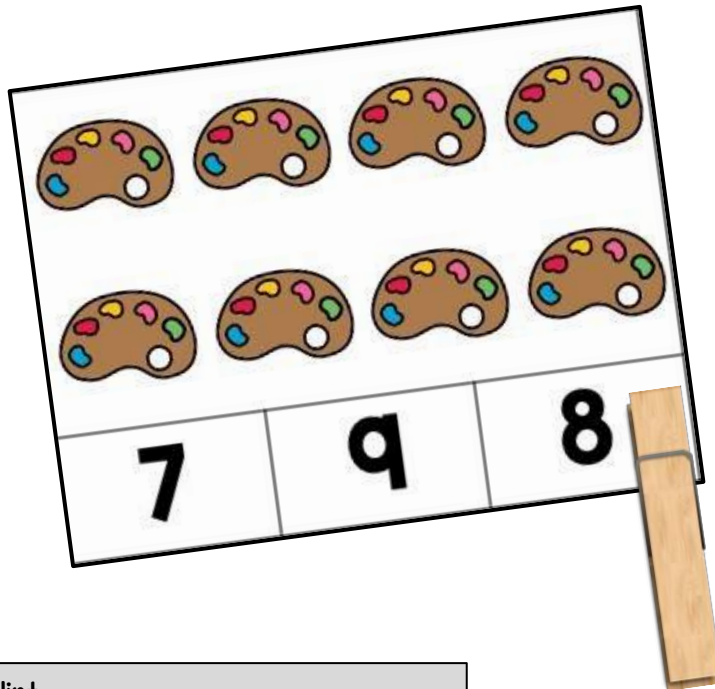

## Helpful Hint:

For easy self-checking, put a sticker on the back that will match the clothes pin if the answer is correct.

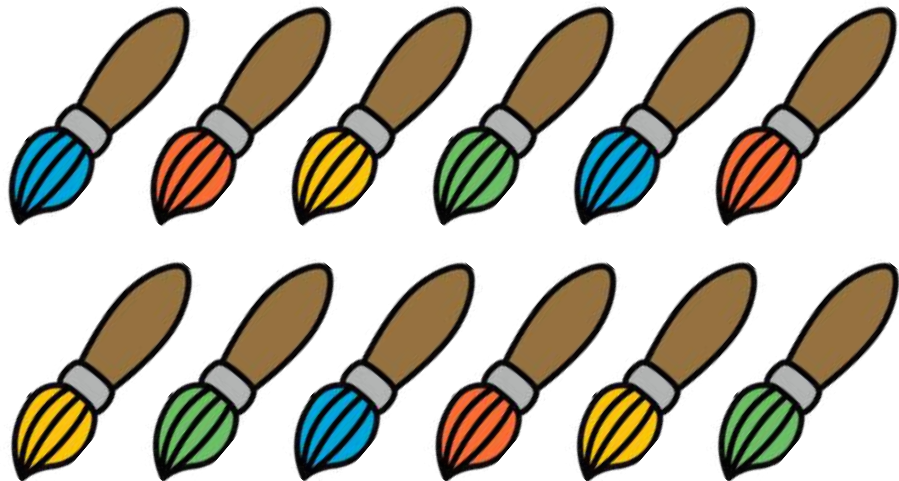

12

8

9



4

11

10

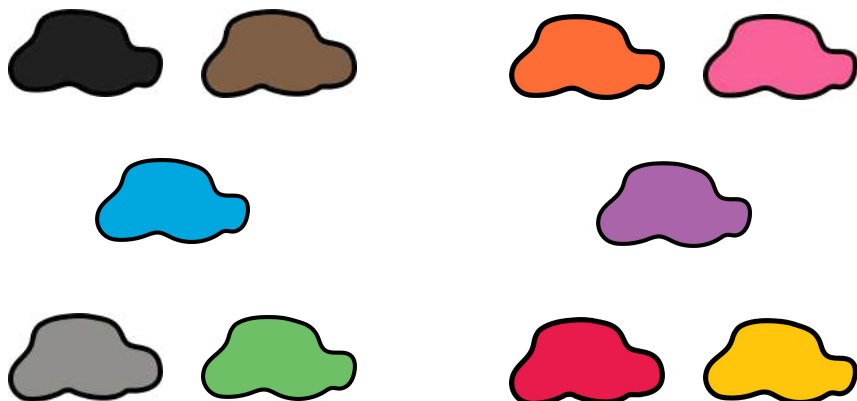

8

6

10

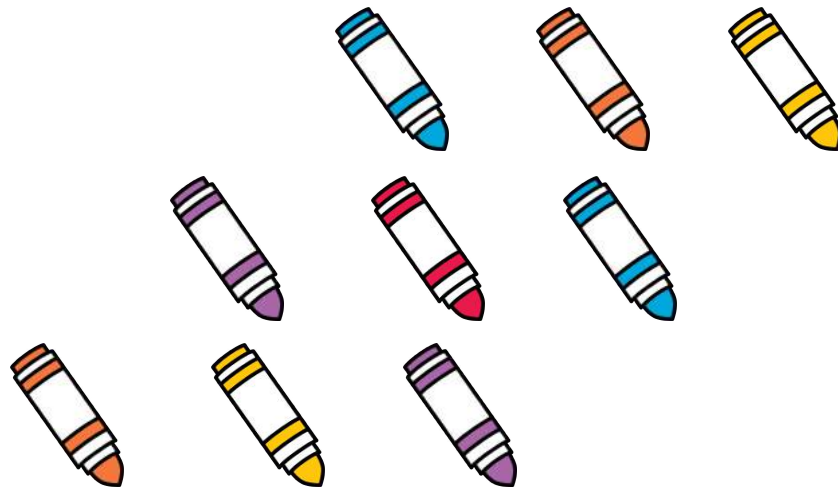

9

6

5

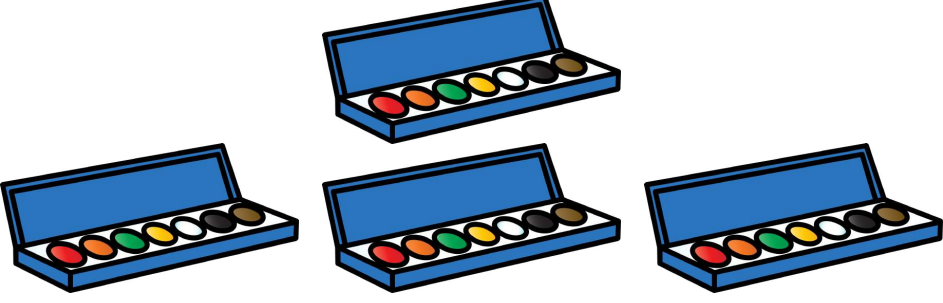
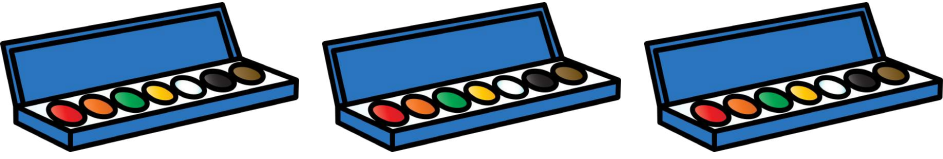

7

9

8

5

7

4

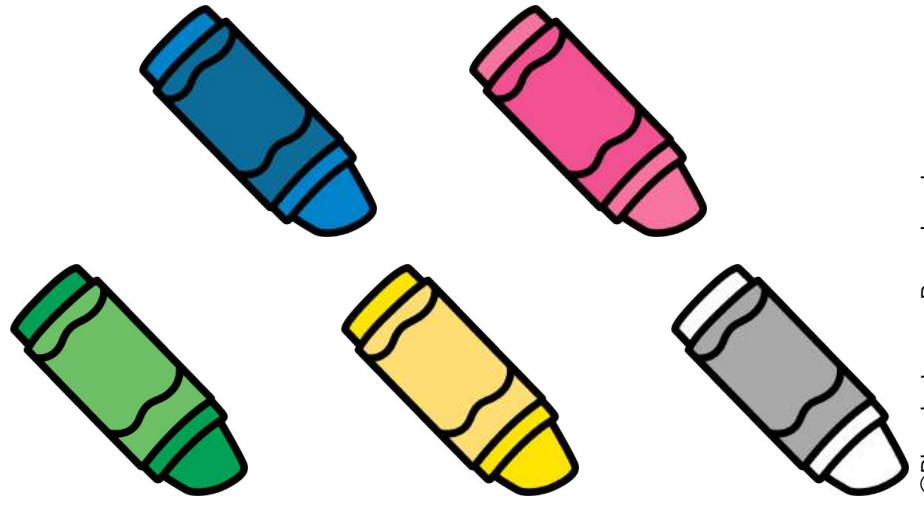

6

3

1

10

5

2

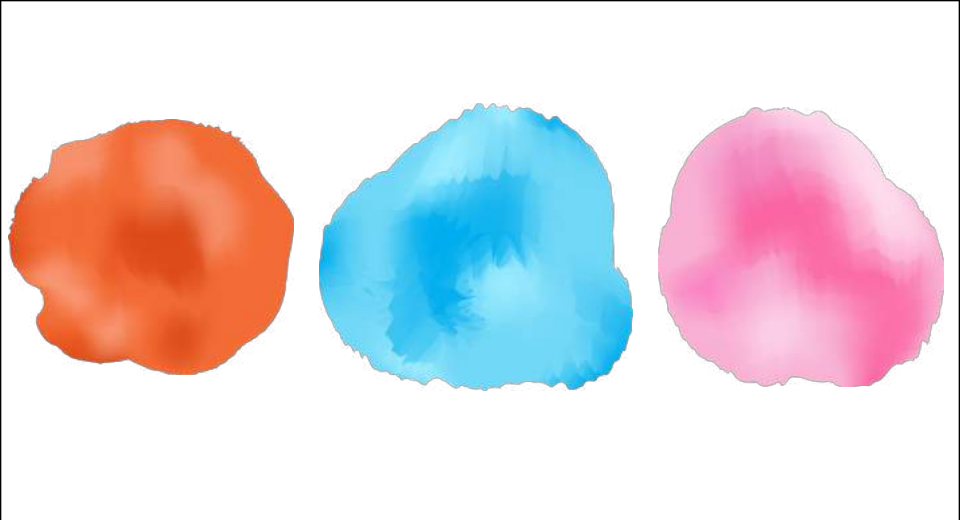
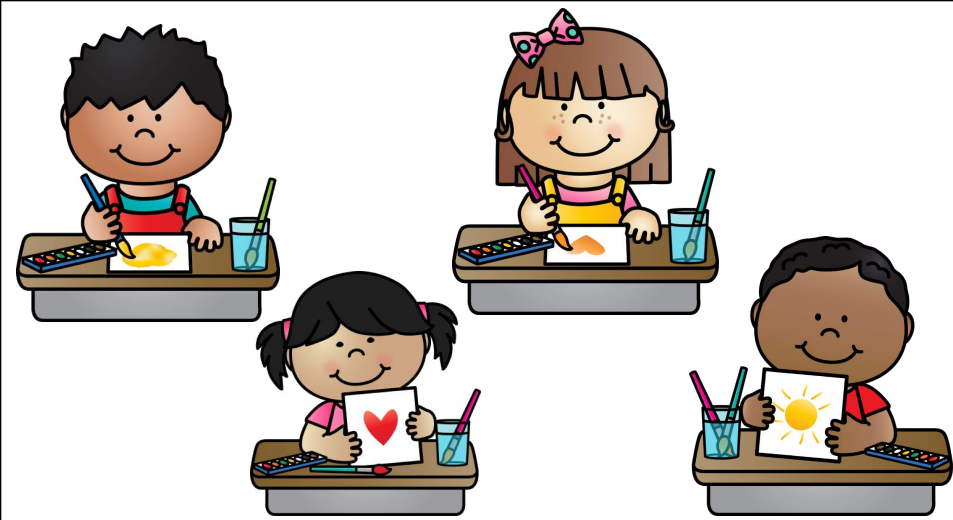

5

2

4

3

7

8

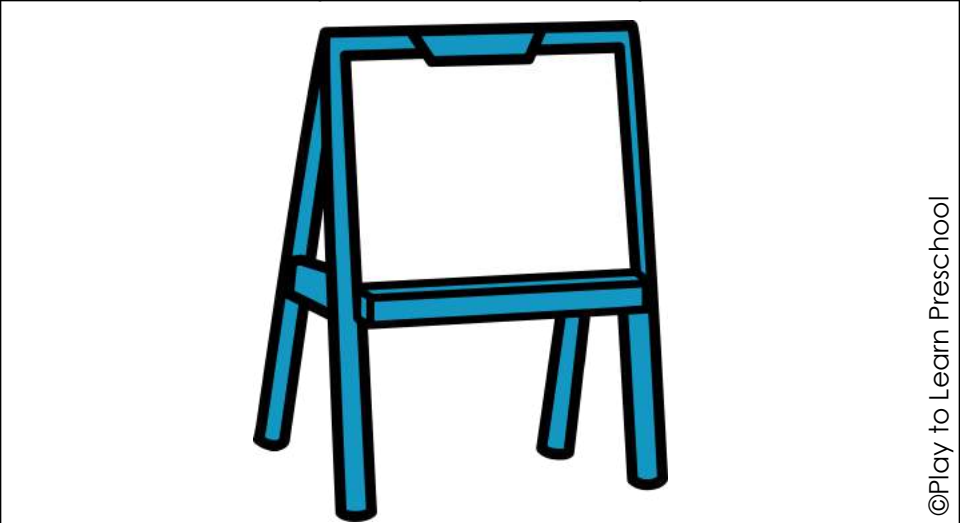

1

2

6

9

5

1

# Color Matching

**Objective:** The students will match items by color.

**Preparation:** Print, mat, cut out, and laminate the pictures. Place large pictures face up on the table and small pictures in an envelope or bag. (Alternatively, create an interactive bulletin board using hook and loop tape or magnets.)



**Procedure:** Students will select a small picture and match it with the corresponding paint tube.

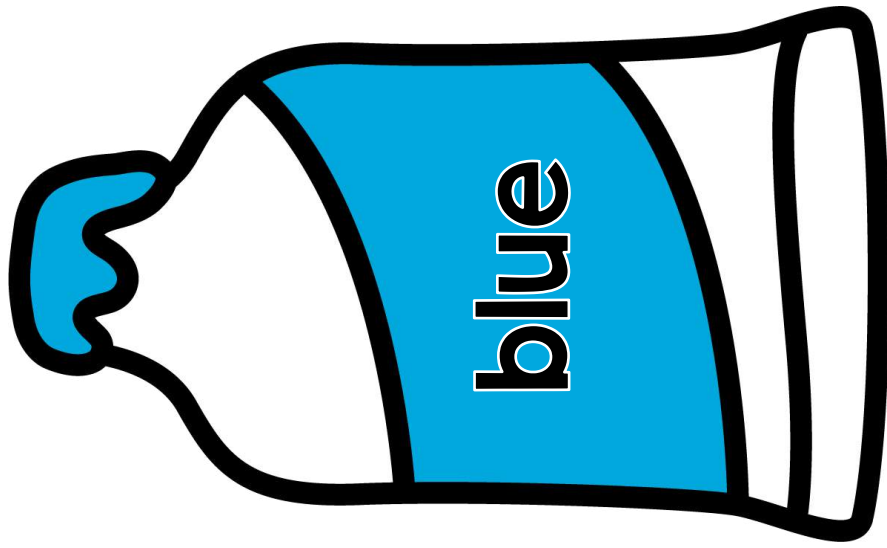

Artist Color Matching

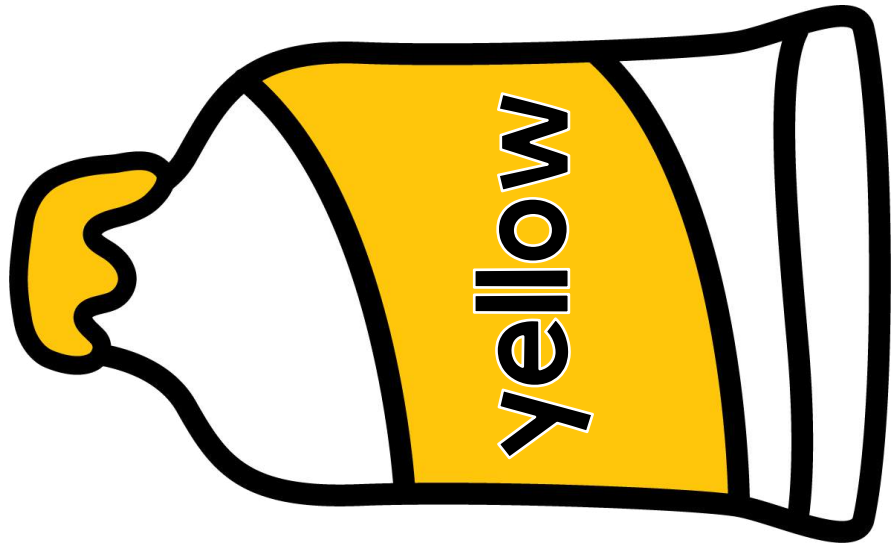

Artist Color Matching

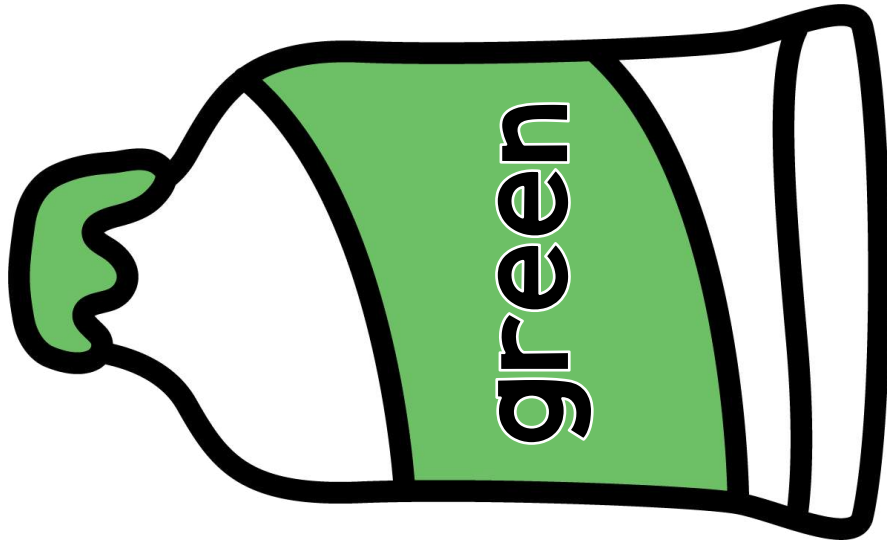

Artist Color Matching

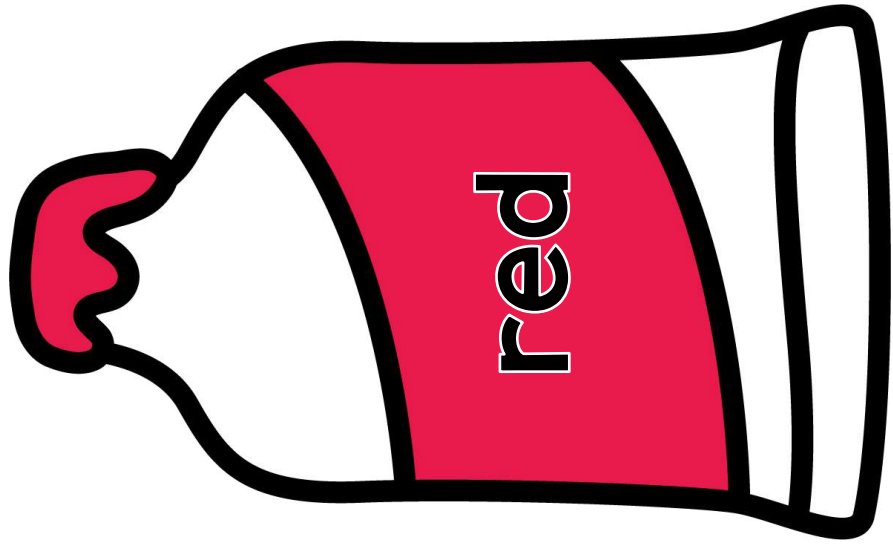

Artist Color Matching

Color Matching



wagon

Color Matching

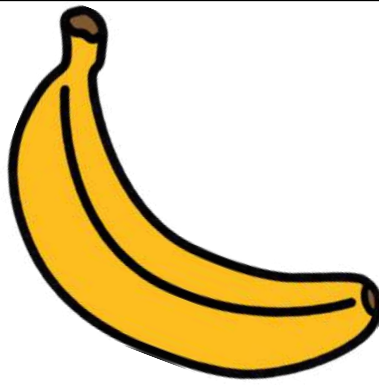

banana

Color Matching

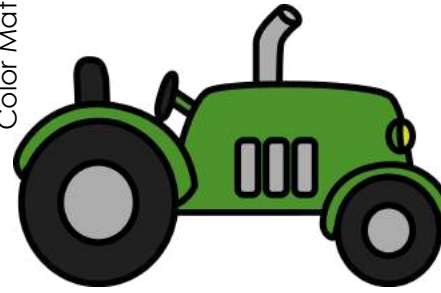

tractor

Color Matching

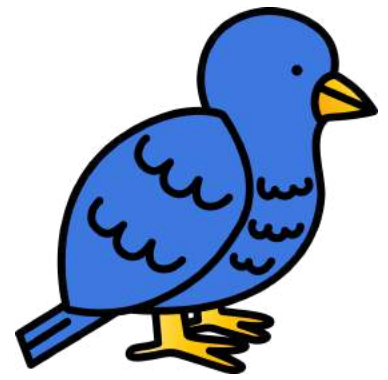

bird

Color Matching

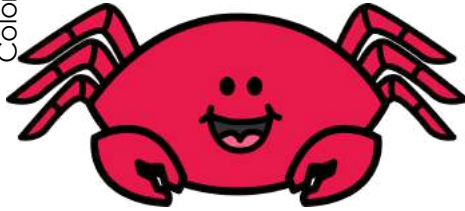

crab

Color Matching



bus

Color Matching

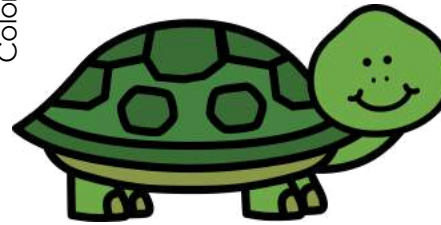

turtle

Color Matching

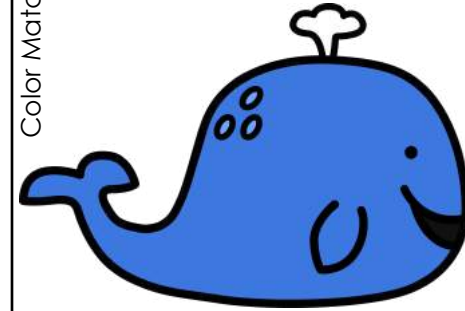

whale

Color Matching



heart

Color Matching

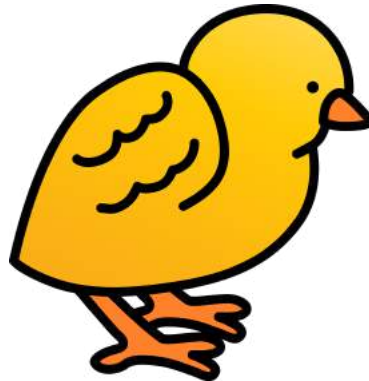

chick

Color Matching



leaf

Color Matching



butterfly

# Shape Sorting

**Objective:** The students will sort objects by property.

**Preparation:** Print, cut out, and laminate all pieces.

**Procedure:** Students choose a picture and match it to the corresponding shape.

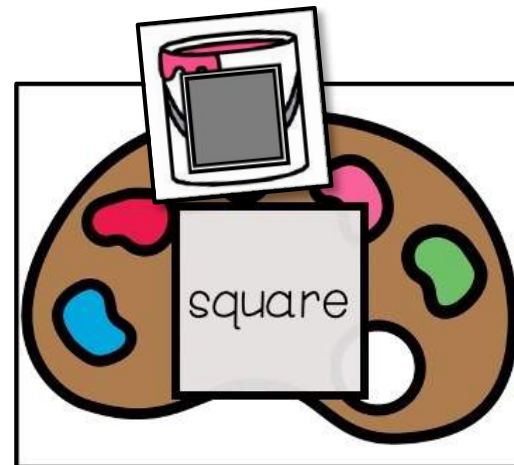

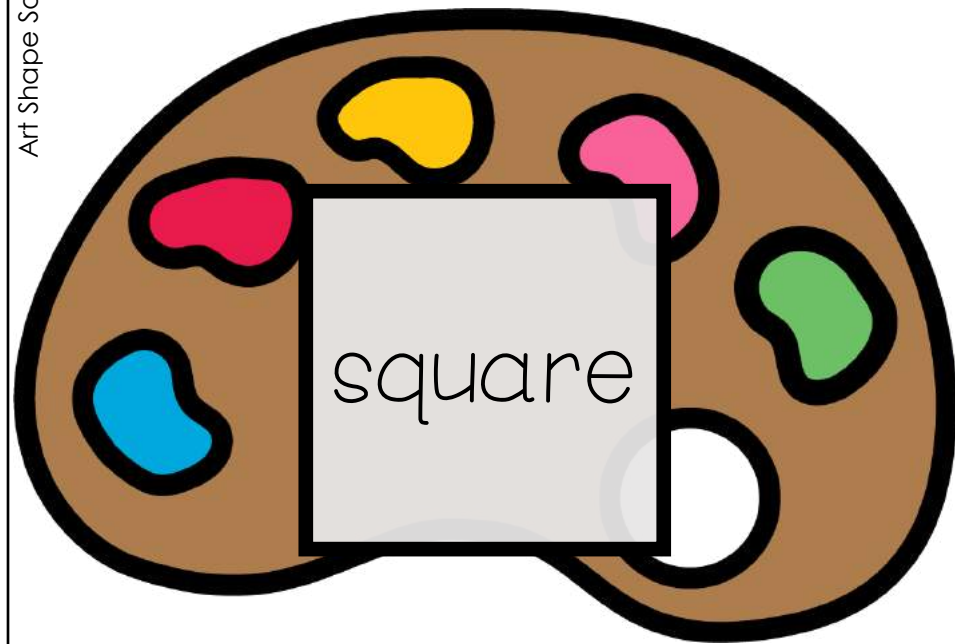
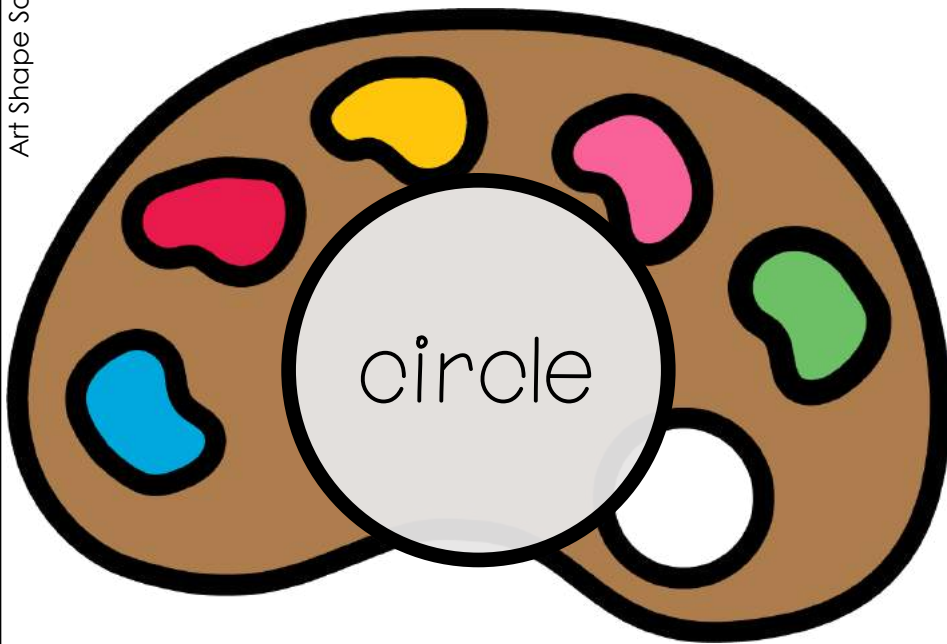

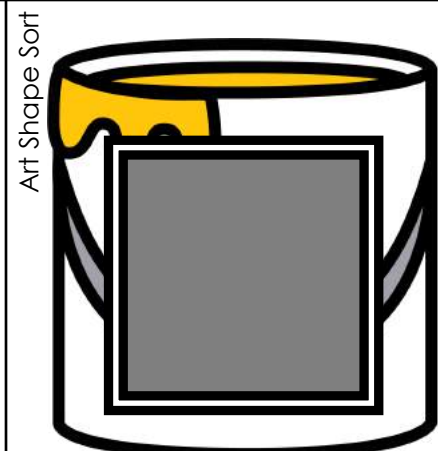
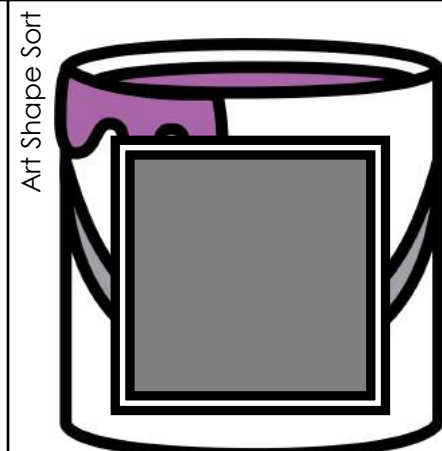
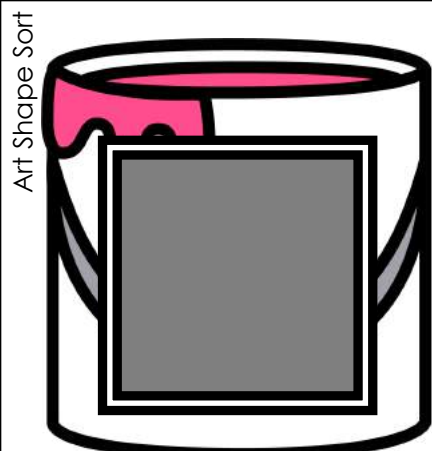
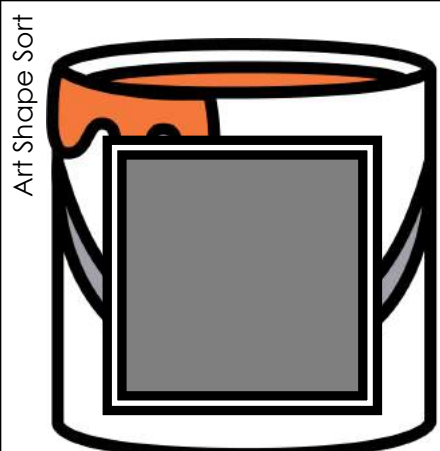
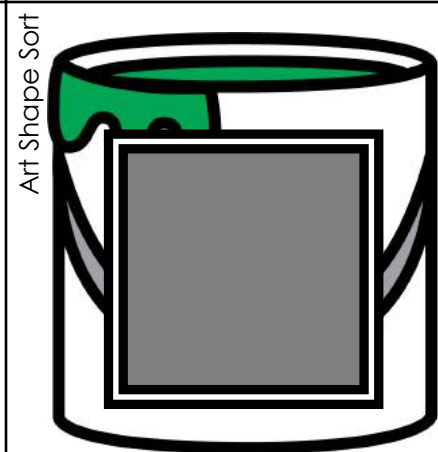
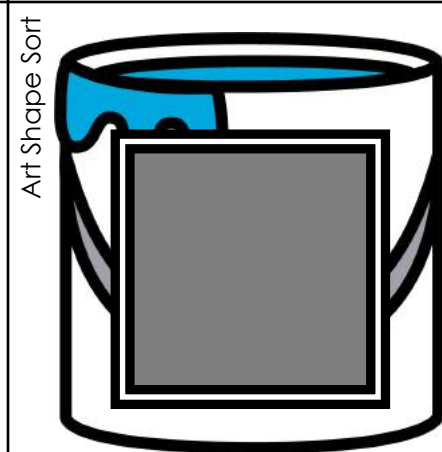
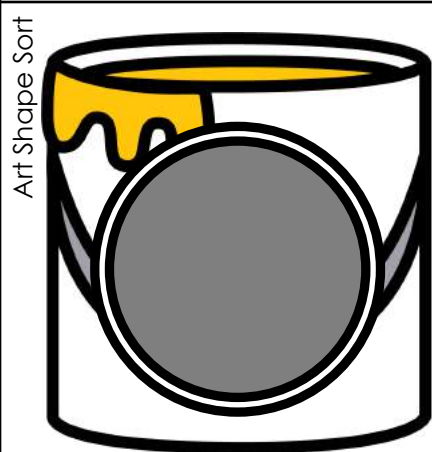
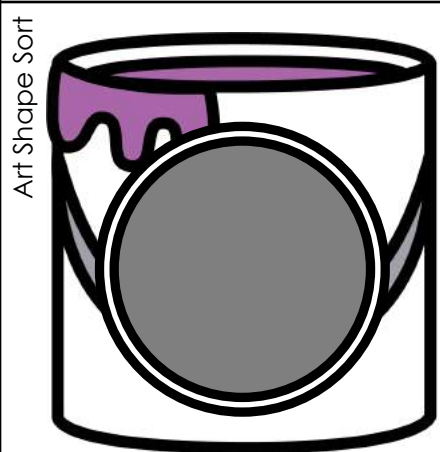
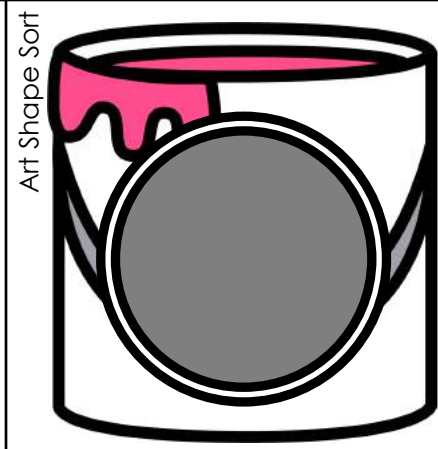
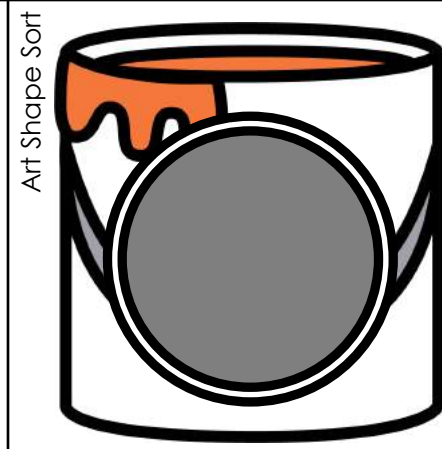
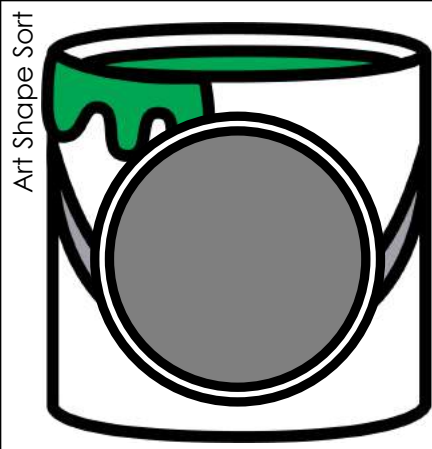
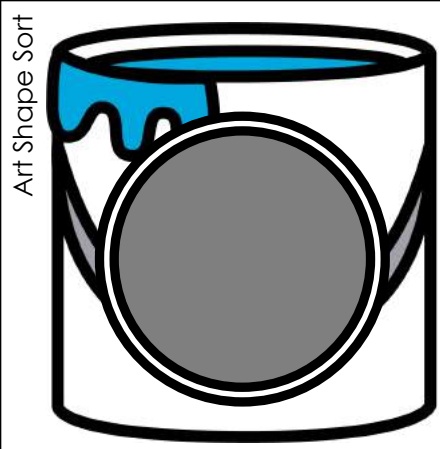

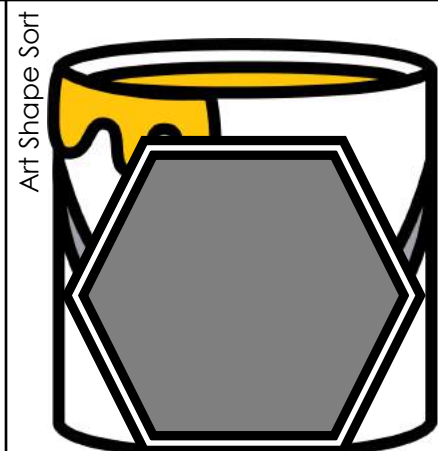
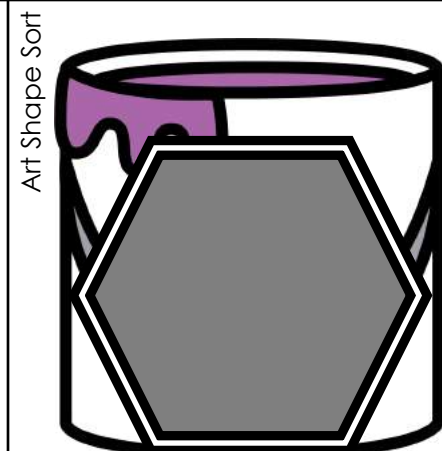
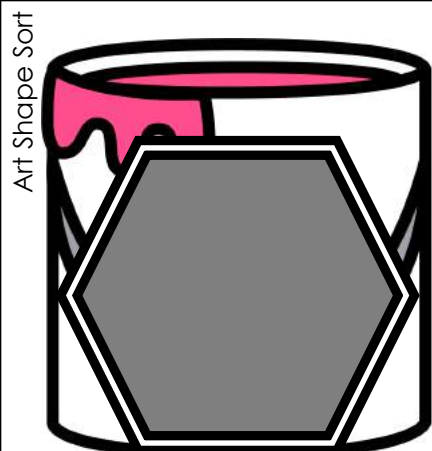
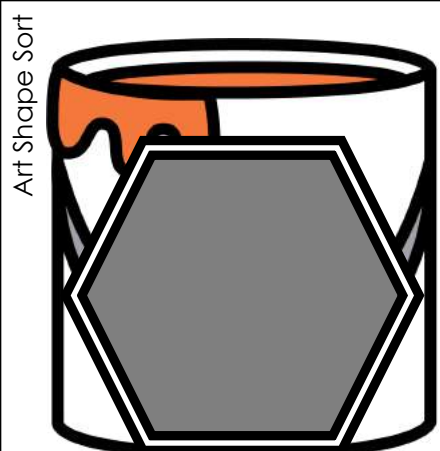
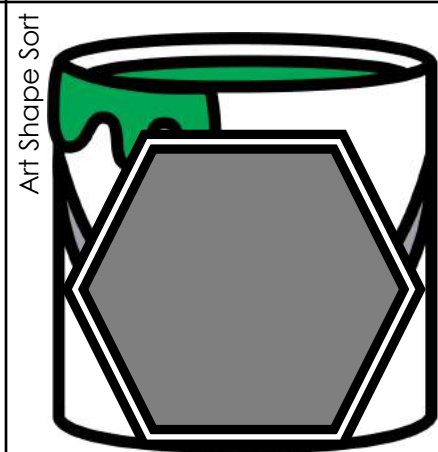
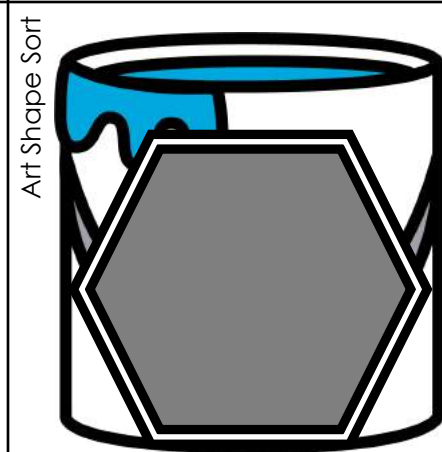
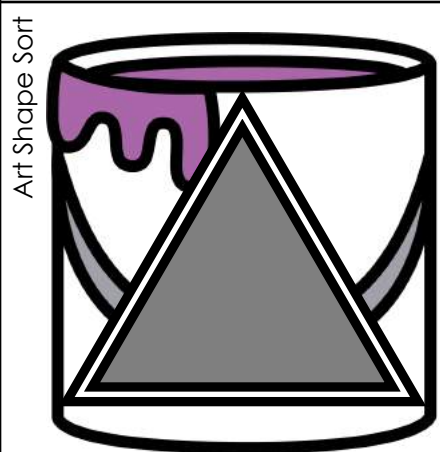
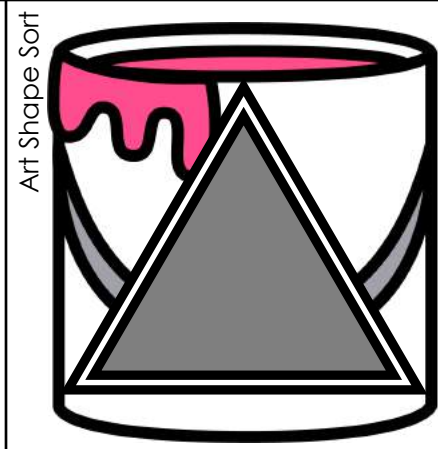
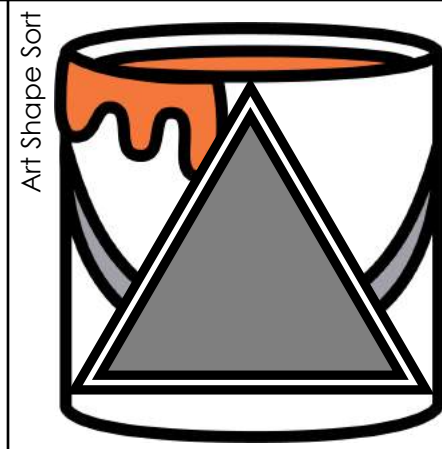
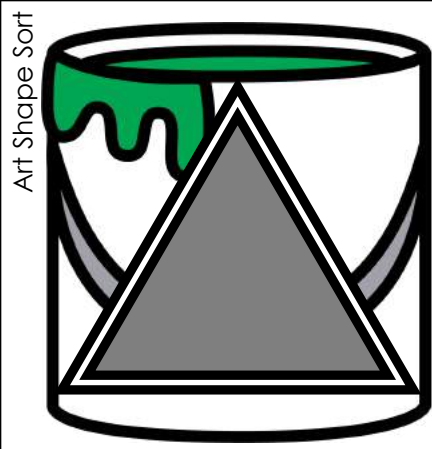
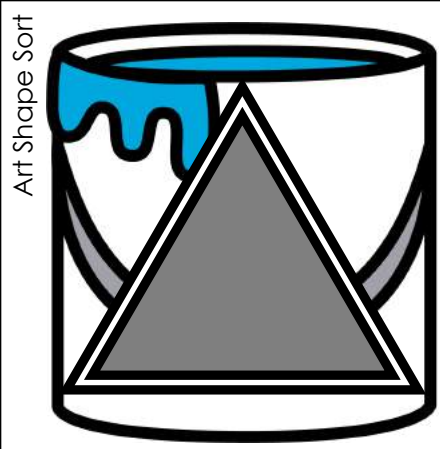

Name \_\_\_\_\_



I can draw the shapes.

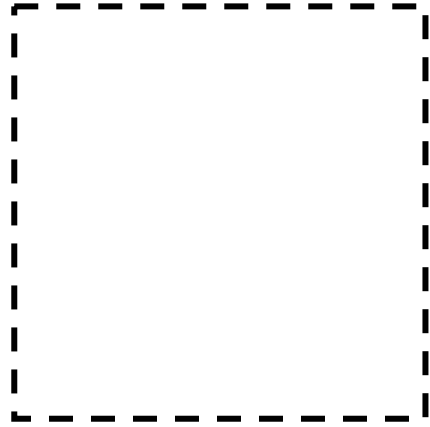

square

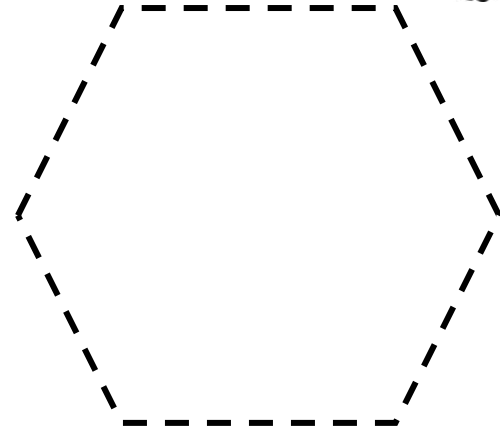

hexagon



triangle

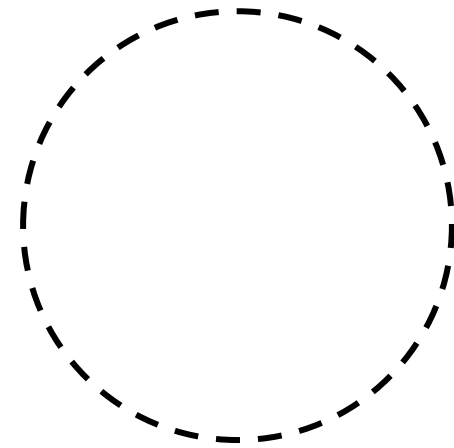

circle

# Concentration

**Objective:** The students will use visual discrimination (matching) skills to identify two identical objects.

**Preparation:** Print the picture cards and mat onto cardstock. Cut apart and laminate as desired.

**Procedure:** Place the cards facing down. Students take turns flipping over 2 cards at a time. If the cards match, the student gets to keep the pair. If they don't match, they return them to the face-down position and try again.

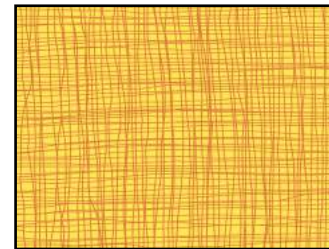
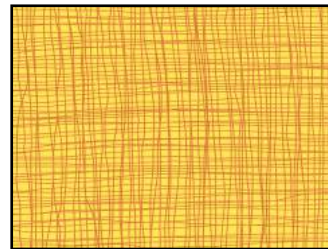
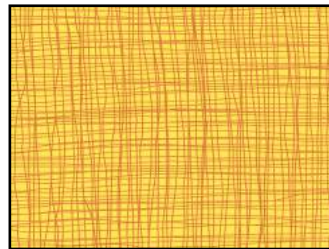
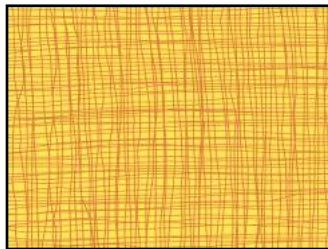
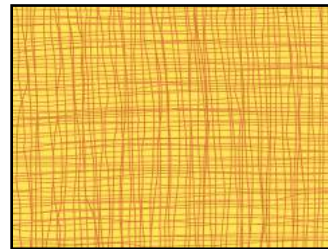
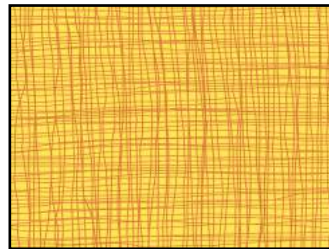
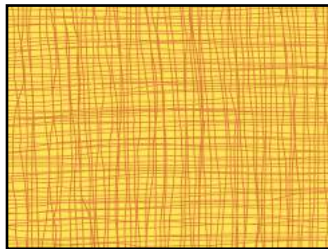
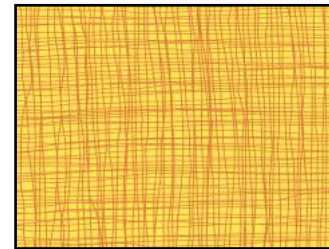
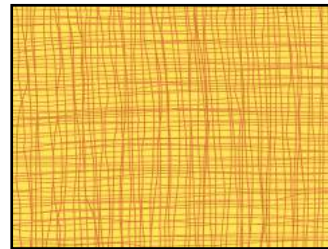
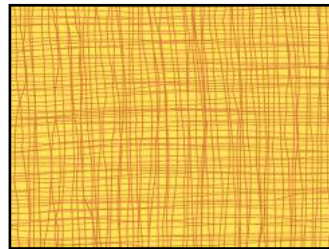

Concentration

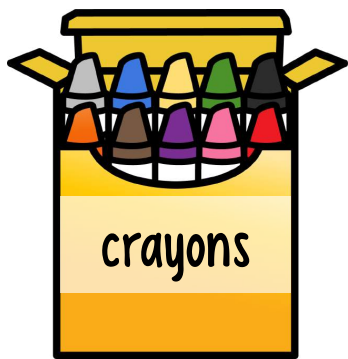

crayons

Concentration



play dough

Concentration

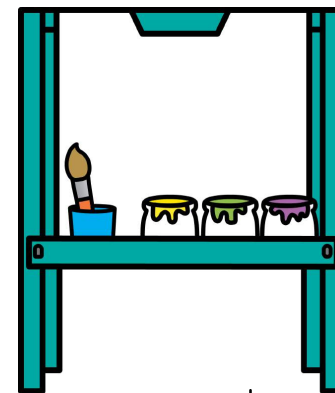

easel

Concentration



palette

Concentration

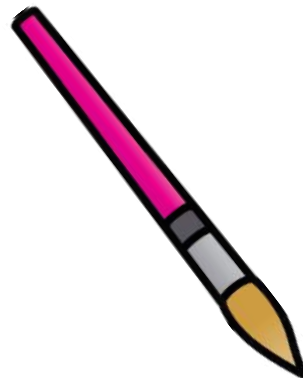

paint brush

Concentration

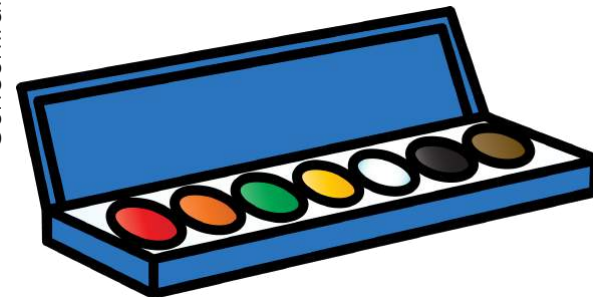

watercolors

Concentration



smock

Concentration

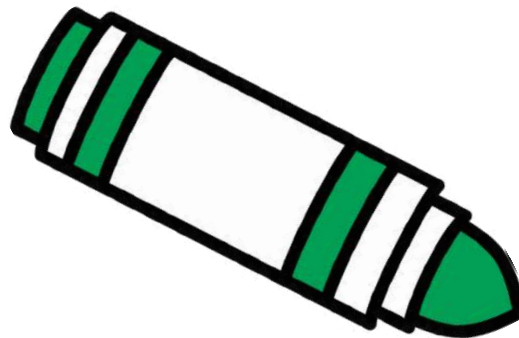

marker

Concentration

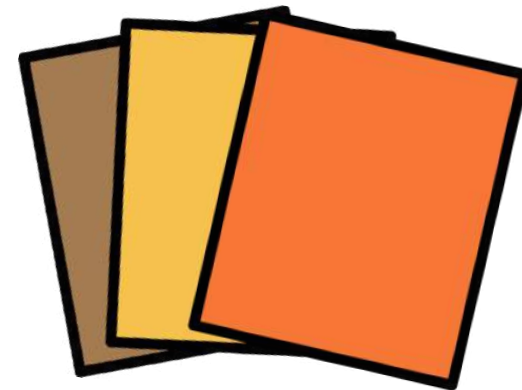

paper

Concentration

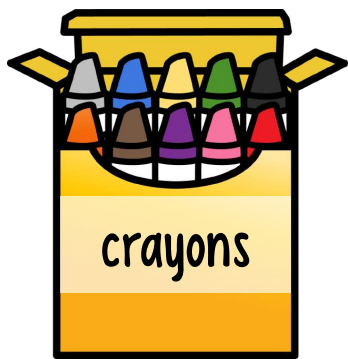

crayons

Concentration



play dough

Concentration

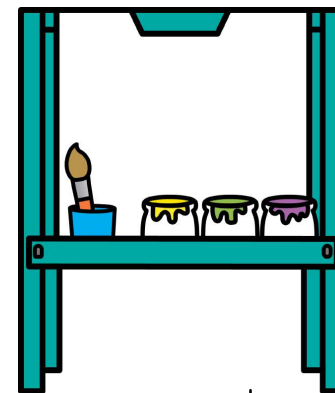

easel

Concentration

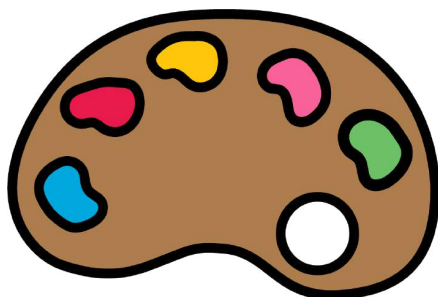

palette

Concentration

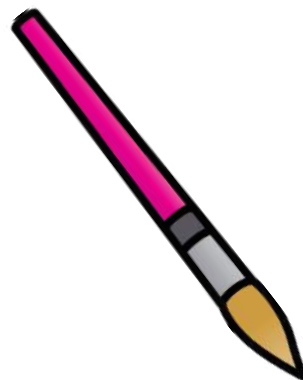

paint brush

Concentration

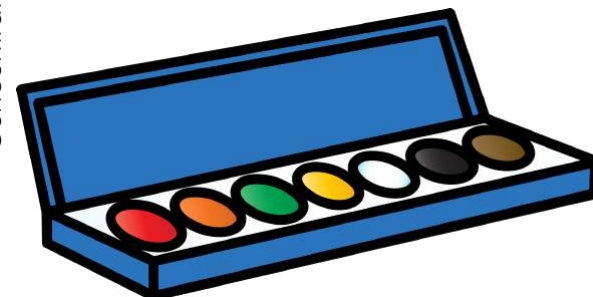

watercolors

Concentration



smock

Concentration

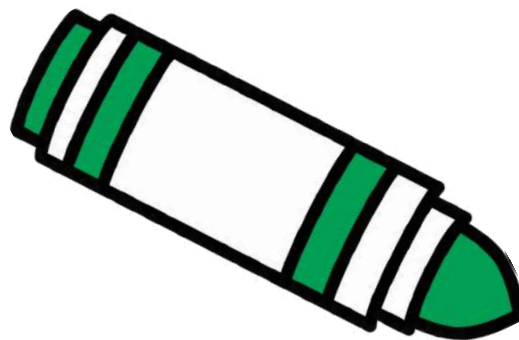

marker

Concentration

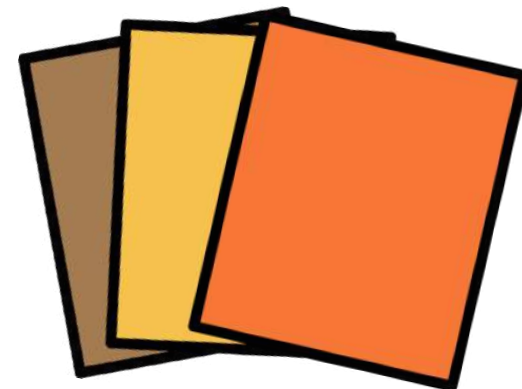

paper

# Cutting Practice

**Objective:** The students will coordinate eye-hand movement and control the small muscles in their hands.

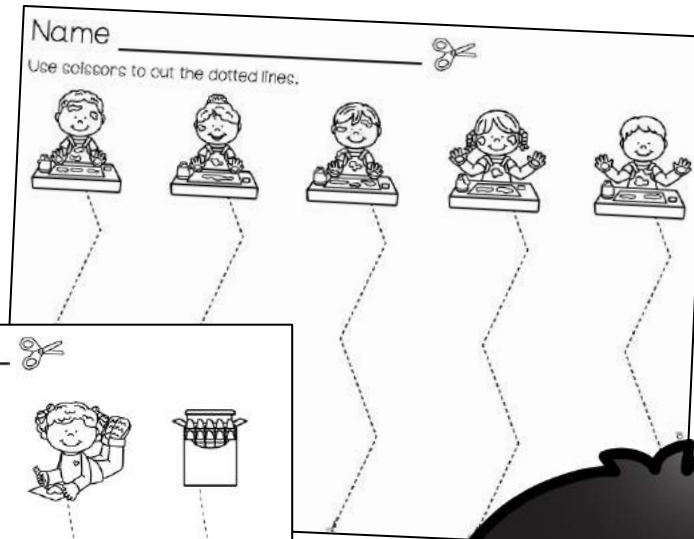
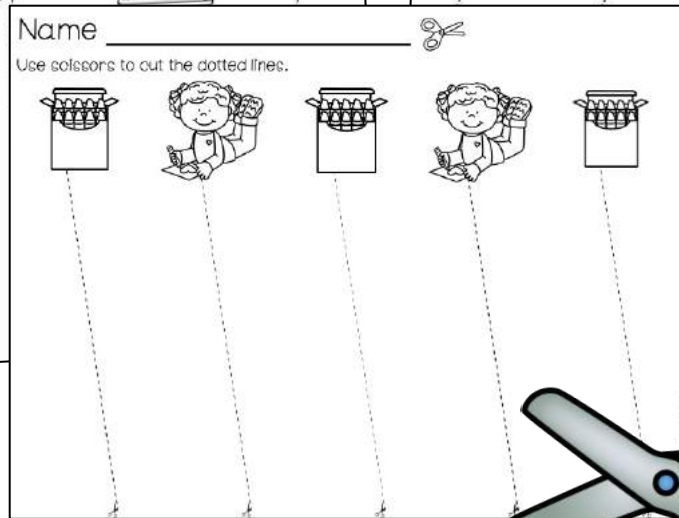
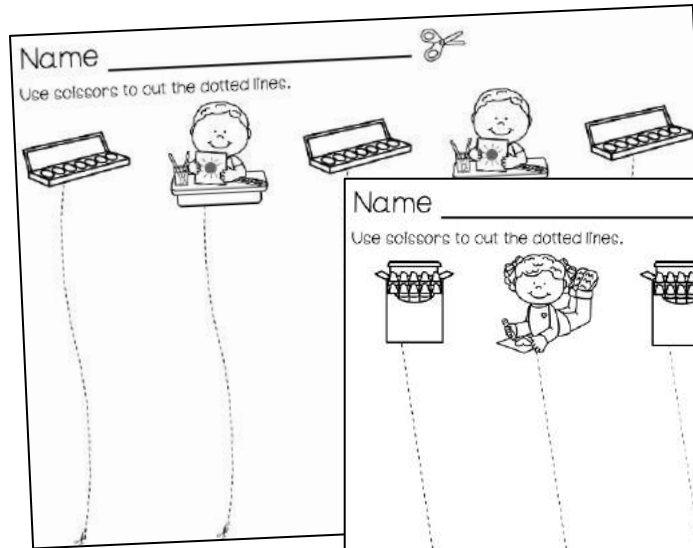

**Preparation:** Print a cutting page for each student. Demonstrate proper scissors usage and guide students to cut along the lines from the bottom to the top.

**Procedure:** The students will cut along the dotted lines from the bottom of the page to the top.

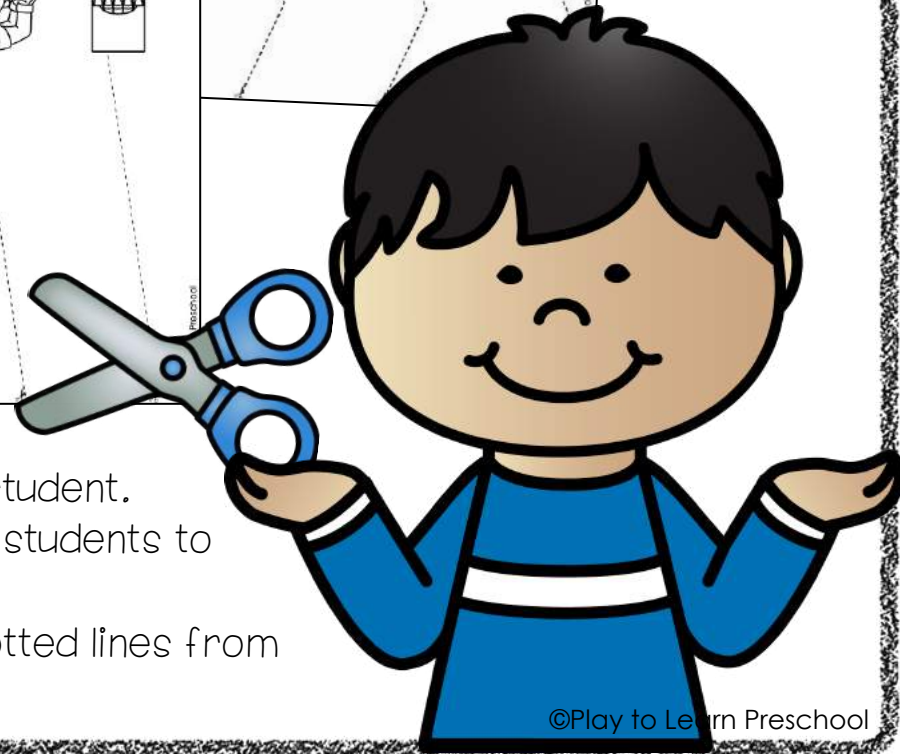

Name \_\_\_\_\_

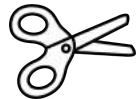

Use scissors to cut the dotted lines.

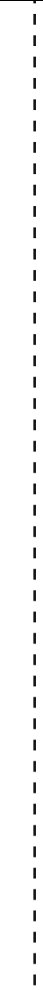
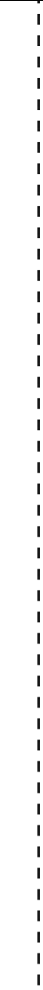
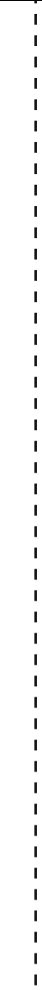

Name \_\_\_\_\_



Use scissors to cut the dotted lines.

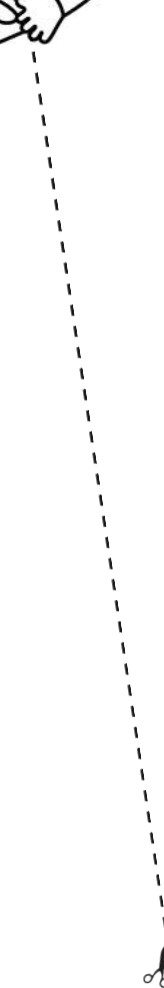
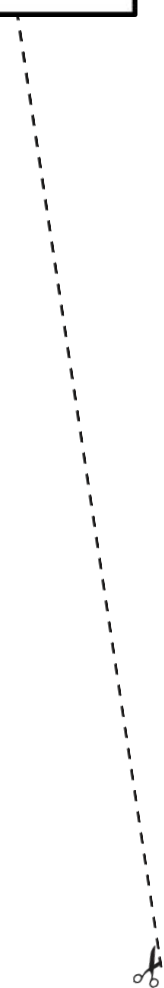
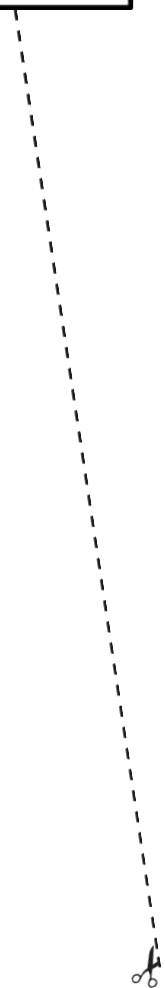
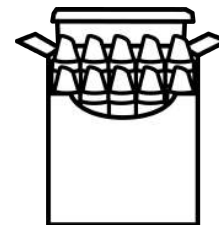
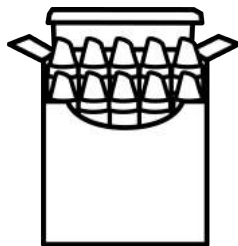
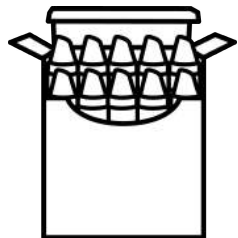

Name \_\_\_\_\_



Use scissors to cut the dotted lines.

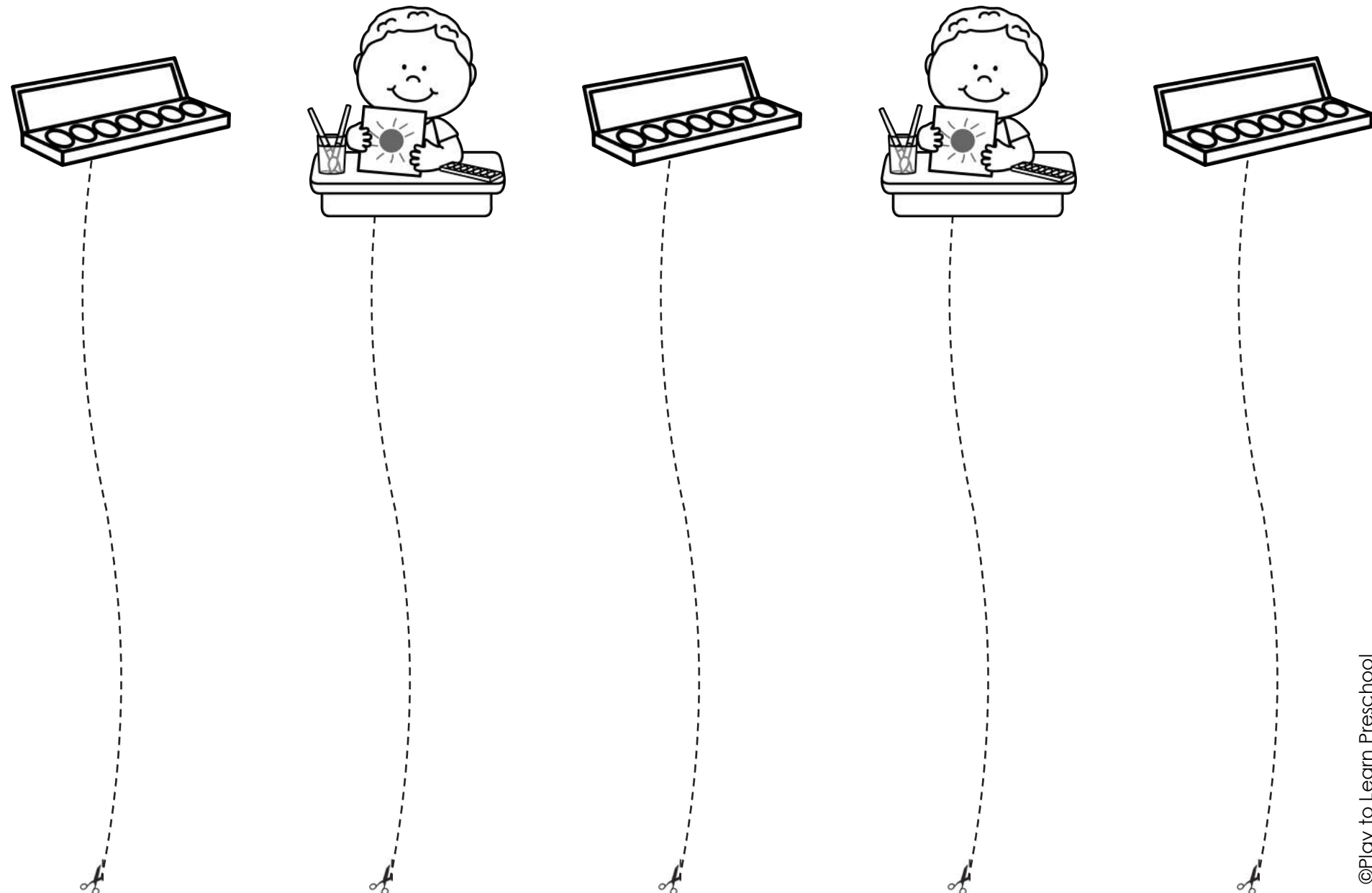

Name \_\_\_\_\_

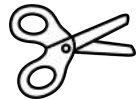

Use scissors to cut the dotted lines.

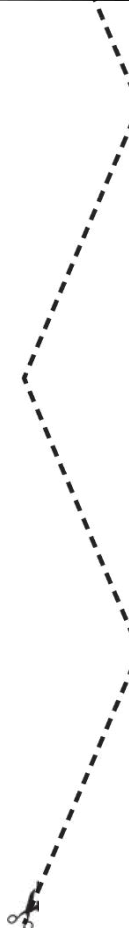
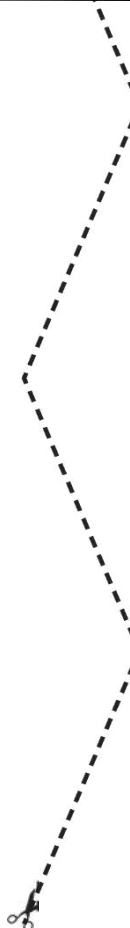
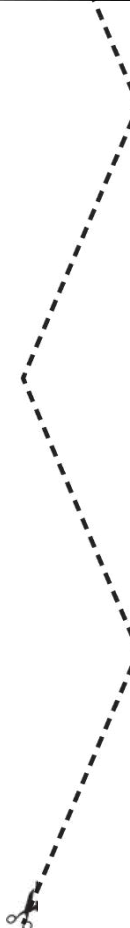
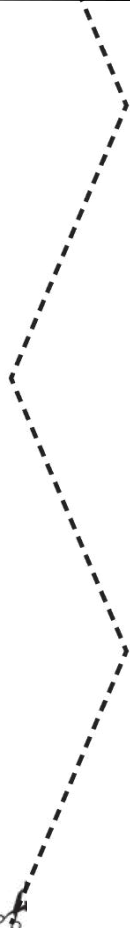
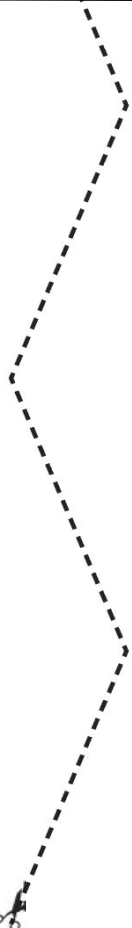

# Picture Puzzles

**Objective:** The students use hand-eye coordination and fine motor skills to assemble a puzzle.

**Preparation:** Copy each page, mat, cut, and laminate as desired.

**Procedure:** Students match the puzzle pieces together.



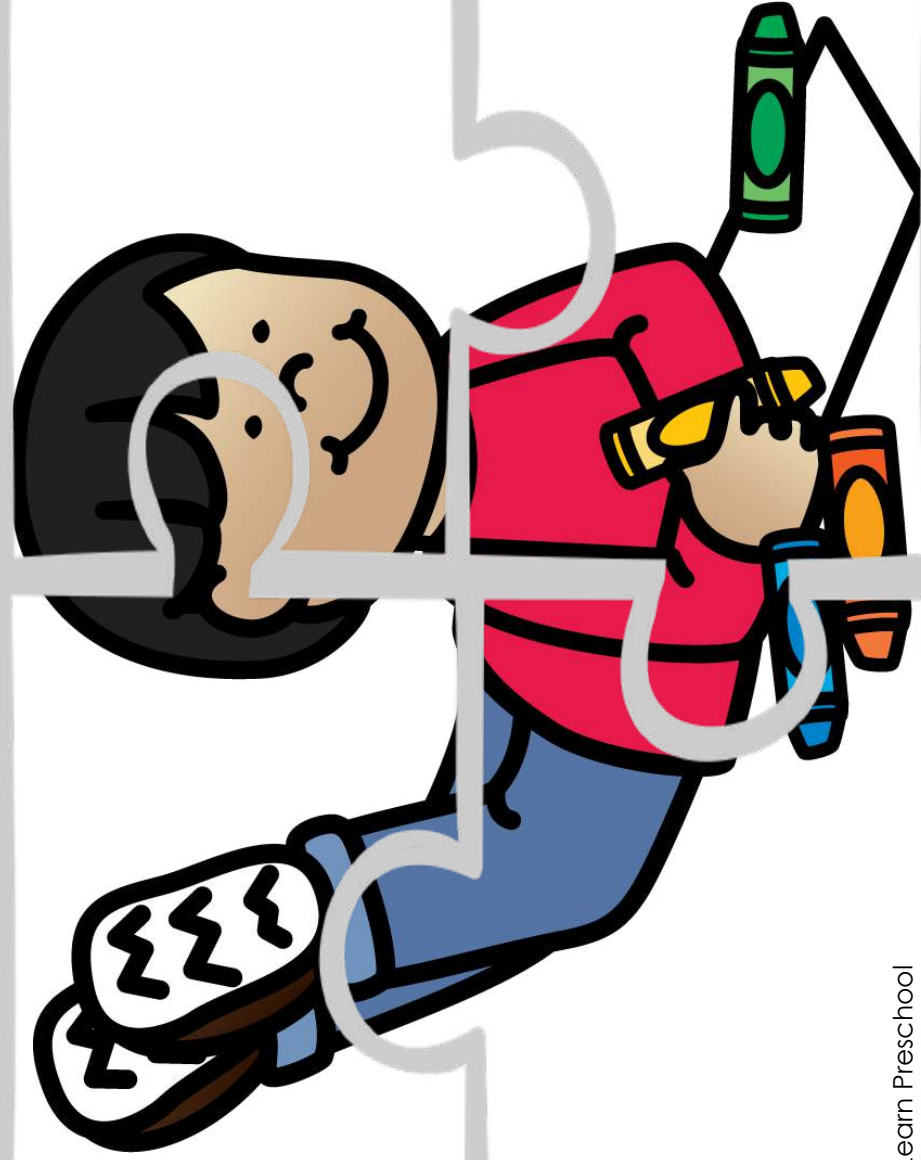
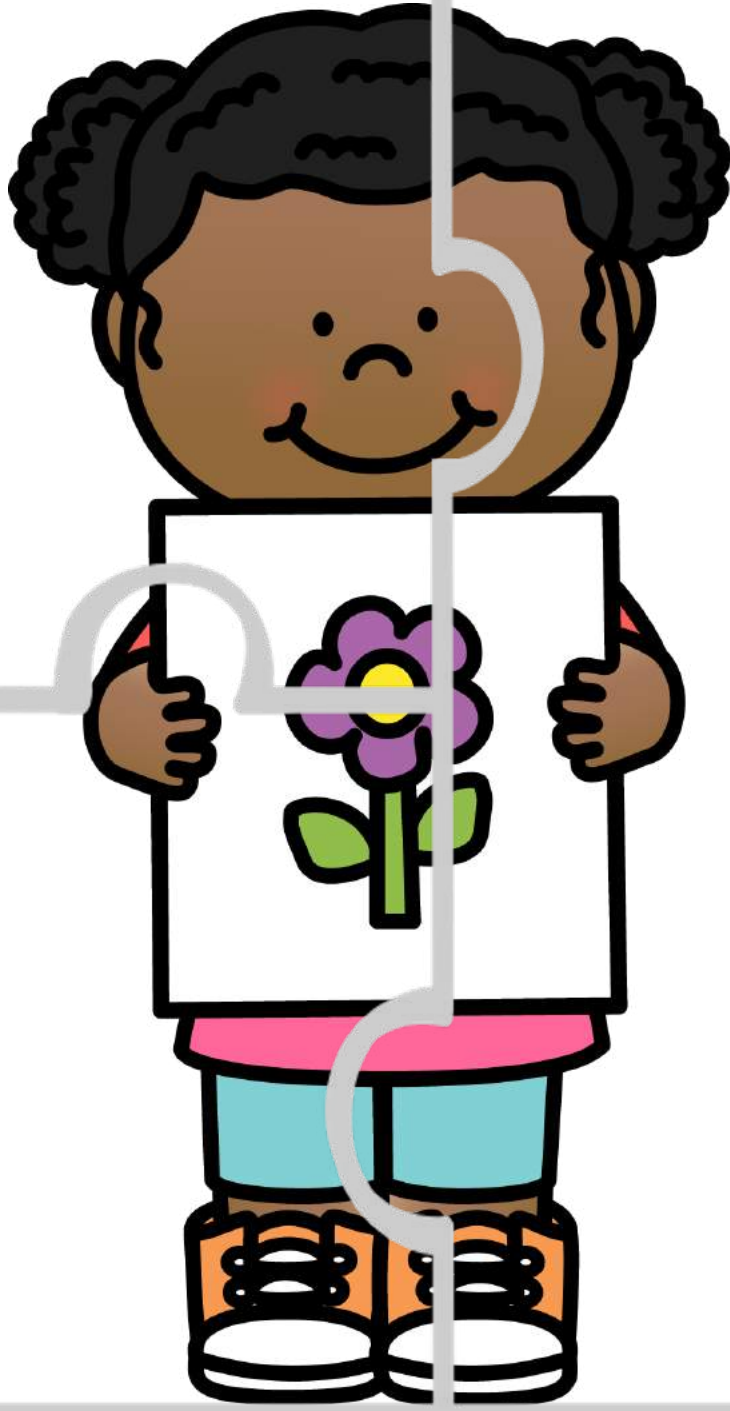

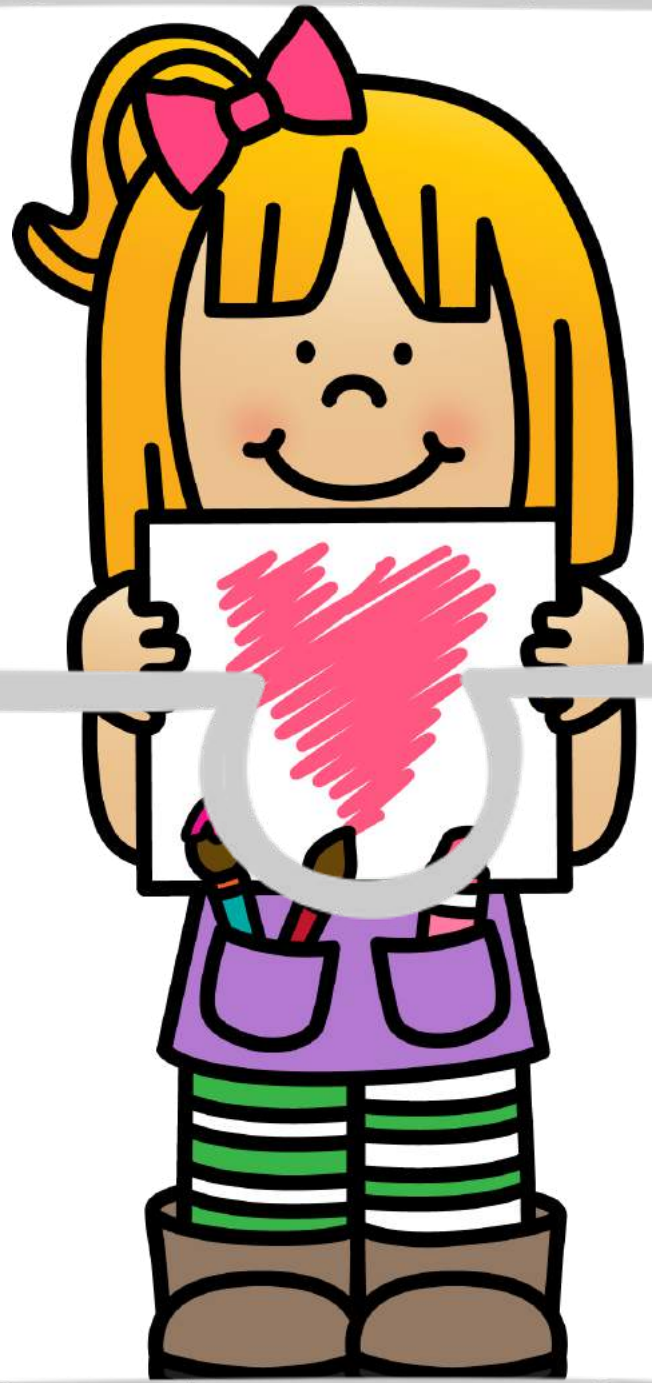
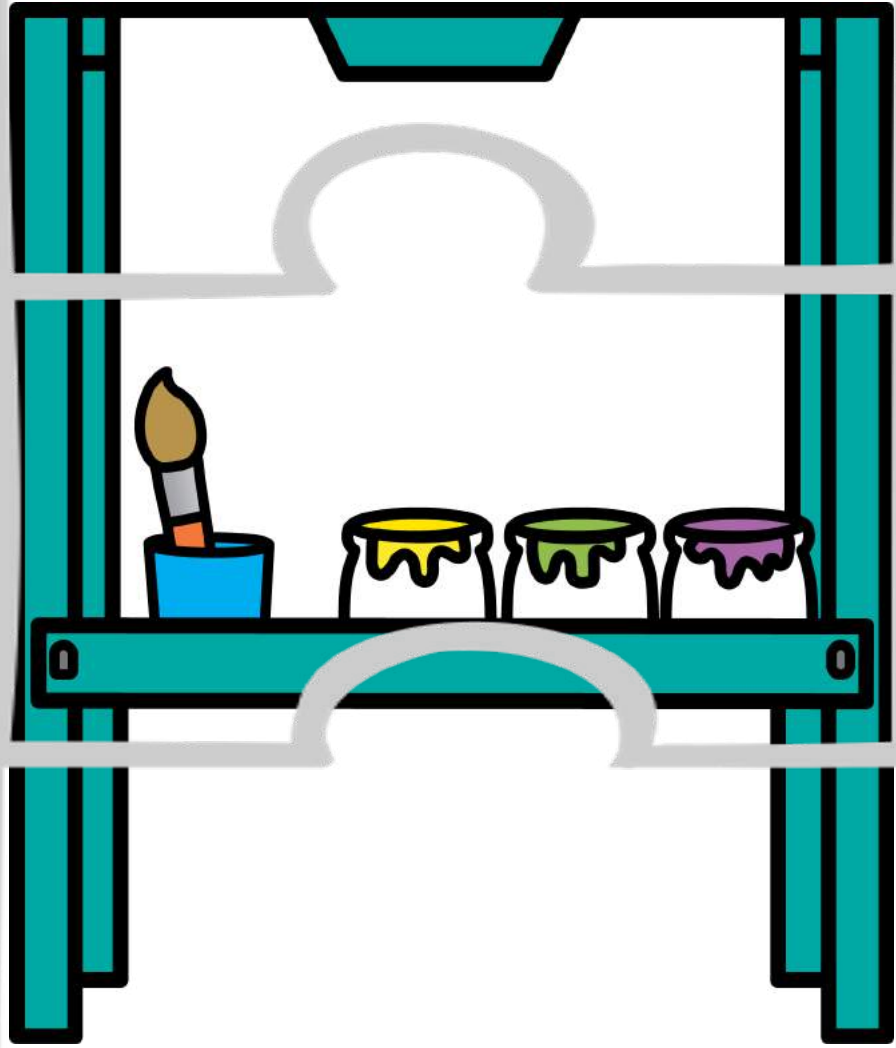



# Journaling

**Objective:** The students will understand the purpose of writing.

**Procedure:** Print the journal sheets. Students can use the journal prompts to write and draw a picture. The words can also be written for the student if necessary.

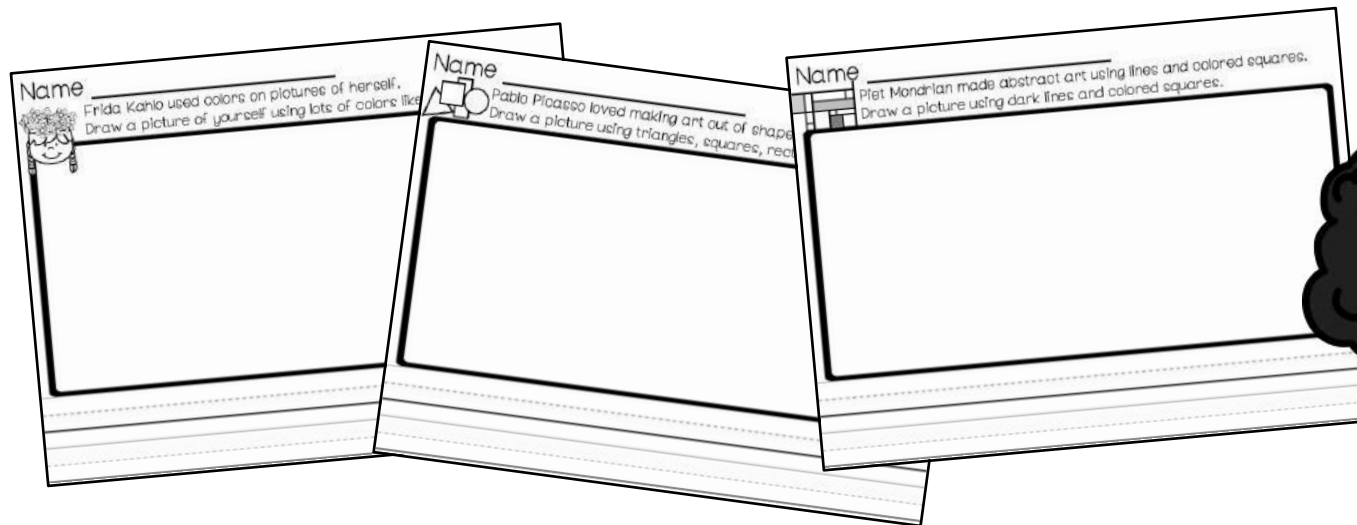

Learning to draw and write is a developmental process. Young children need lots of time and opportunities to scribble, draw, and write. This is called “emergent literacy.” The following is a very *general* guide to how children progress:

## Early (ages 3-4)

- Read the prompt to the child and talk about it together.
- Encourage the child to draw a picture. It’s okay if it is not yet a recognizable shape or image.
- Ask the child to tell about the picture. “Can you tell me about your picture?”
- Repeat what they say and write down your child’s dictation on the lines. Be sure to date it!

## Intermediate (ages 4-5)

- Read the prompt to the child and talk about it together.
- Encourage the child to draw a picture.
- Ask the child to tell about the picture. “Can you tell me about your picture?”
- Encourage the child to write about it on the lines. (The child will likely make scribbles or letter-like formations.)
- Ask your child if they want you to write their dictation on the lines as well.

## Advanced (ages 5-6)

- Read the prompt to the child and talk about it together.
- Encourage the child to draw a picture and label it.
- Model for your child how to say a word, stretch it out and listen for the sounds that they hear.
- For example, if they draw a bear, say “bear.” Listen for the B sound and write the letter B to match. Can they hear any other sounds? Maybe they can also hear and write the letter R.
- Children may ask for you to write words for them to copy on the lines. This is fine as long as you also encourage them to write the letters and sounds that they hear.

Name \_\_\_\_\_

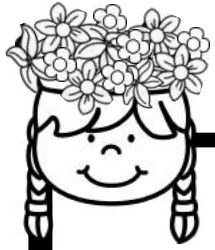

Frida Kahlo used colors on pictures of herself.

Draw a picture of yourself using lots of colors like Frida Kahlo.

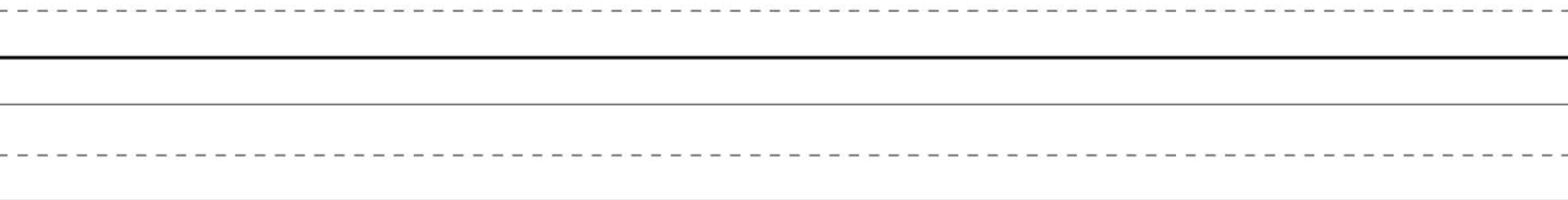

Name \_\_\_\_\_

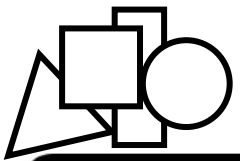

Pablo Picasso loved making art out of shapes.

Draw a picture using triangles, squares, rectangles, and circles.



Name \_\_\_\_\_

Yoyoi Kusama created pictures using dots.  
Draw a picture using dots below..



Name \_\_\_\_\_

Piet Mondrian made abstract art using lines and colored squares.  
Draw a picture using dark lines and colored squares.





# Artist Books

## for Preschoolers



### Fiction

- *The Museum* by Susan Verde
- *Anna at the Art Museum* by Hazel Hutchins and Gail Herbert
- *Parker Looks Up* by Parker Curry and Jessica Curry
- *My Museum* by Joanne Liu
- *Luna Loves Art* by Joseph Coelho
- *Mayhem at the Museum* by Luciano Lozano
- *I Ain't Gonna Paint No More!* by Karen Beaumont
- *Ellie* by Mike Wu
- *Elmer* by David McKee
- *Beautiful Oops!* By Barney Saltzberg
- *Maybe Something Beautiful* by F. Isabel Campoy
- *Perfect Square* by Michael Hall
- *The Artist Who Painted a Blue Horse* by Eric Carle
- *I am an Artist* by Marta Altés
- *Time to Make Art* by Jeff Mack
- *ABCs of Art* by Sabrina Hahn
- *Colors in Art* by Sabrina Hahn
- *Animals in Art* by Sabrina Hahn

### Alma Thomas

- *Alma's Art* by Roda Ahmed
- *Ablaze with Color* by Jeanne Walker Harvey

### Pablo Picasso

- *Picasso Loves Shapes* by Judiee Lee
- *Pablo Picasso (Little People Big Dreams)* by Ma Isabel Sánchez Vegara

### Yoyoi Kusama

- *Yayoi Kusama* by Fausto Gilberti
- *The Nuts: Sing and Dance in Your Polka Dot Pants* by Eric Litwin

### Vincent Van Gough

- *Vincent Paints His House* by Tedd Arnold
- *Vincent's Colors* by Vincent Van Gough
- *Camille and the Sunflowers* by Laurence Anholt
- *Katie and the Starry Night* by James Mayhe

### Non-Fiction

- *This Little Artist: An Art History Primer* by Joan Holub
- *Women Artists A to Z* by Melanie LaBarge
- *ABCs of Art* by Sabrina Hahn
- *123s of Art* by Sabrina Hahn
- *Henri's Scissors* by Jeanette Winter
- *My First Artists (Little People Big Dreams)* by Ma Isabel Sánchez Vegara
- *The Art of Eric Carle* by Eric Carle

### Wassily Kandinsky

- *The Dot* by Peter H. Reynolds
- *Wassily Kandinsky* by Marisa Boon
- *Meet Wassily Kandinsky (Meet the Artist)* by Read with you center for excellence in STEAM education

### Piet Mondrian

- *Mondrian* by Susanne Deicher
- *Meet Piet Mondrian (Meet the Artist)* by Read with you center for excellence in STEAM education
- *Perfect Square* by Michael Hall

### Andy Warhol

- *Andy Warhol What Colors Do You See?* by The Andy Warhol Foundation
- *Uncle Andy's Cats* by James Warhola
- *Andy Warhol (Little People Big Dreams)* by Ma Isabel Sánchez Vegara

### Frida Kahlo

- *Frida* by Jonah Winter
- *Frida Kahlo (Little People Big Dreams)* by Ma Isabel Sánchez Vegara
- *Frida Kahlo and her Animalitos* by Monica Brown
- *My Little Golden Book About Frida Kahlo* by Silvia López
- *I am Frida Kahlo* by Brad Meltzer
- *Little Frida* by Anthony Browne

# More resources

for preschool and Pre-K learners:

Connect:



[Newsletter](#)

[Facebook](#)

[Instagram](#)

[Blog](#)

[Pinterest](#)

## Resource Bundle

save  
\$\$

Credit:

These talented artists made this possible.



kimberly  
geswein  
fonts



# Alphabet Activities

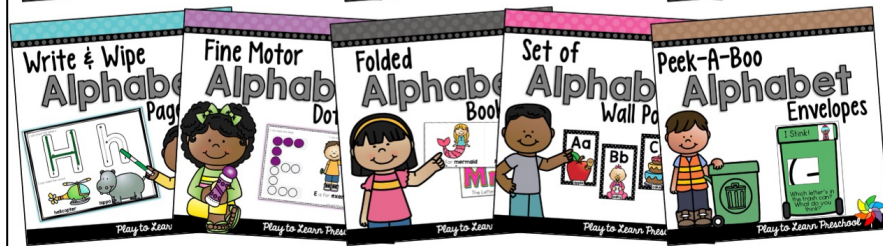
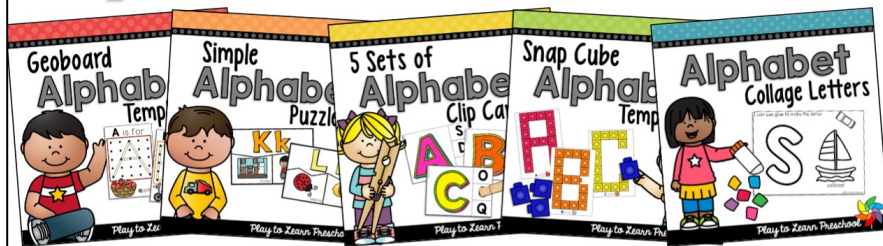

## for Preschoolers

Play to Learn Preschool



These alphabet activities will help your young learner learn the letters of the alphabet!

## Terms of Use:

Play to Learn resources are for personal classroom and home use only. They may not be used commercially.

### YES:

- You may use this resource at home with your own children or in your classroom with your own students.
- You may print copies for your own children or students.
- You may send printed copies home with your students.
- You may use these lessons yourself to provide virtual teaching videos for your own students who might be learning at home.

### NO:

- You may NOT post this file to any file sharing website. (DropBox, Google Drive, Facebook, Amazon, SeeSaw, etc.)
- You may NOT resell these resources.
- You may NOT send these PDFs via email for students to print at home.
- You may NOT share these PDFs with colleagues via email or otherwise.
- You may not claim these resources or ideas as your own.
- You may NOT use these resources to teach lessons that you **sell** online. (Teaching your own students – great. Selling these lessons, even if you do them yourself, online – not permitted.) This includes OutSchool and similar platforms.