

Circle Time

Colors

Unit for Preschoolers

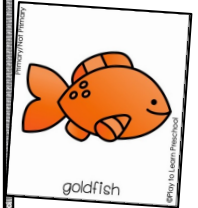
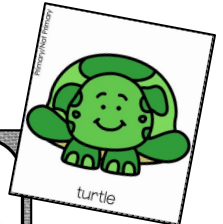
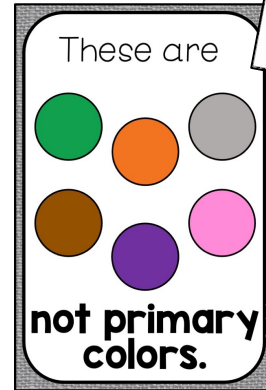
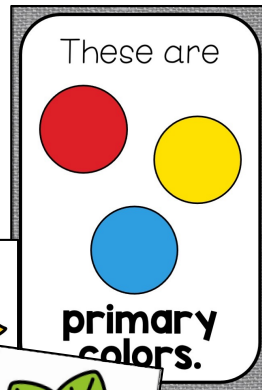
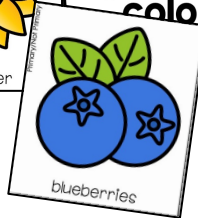
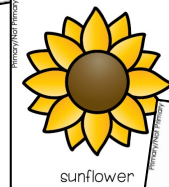

Circle Time Lessons

Unit overview

Bonus Resource: Color Posters

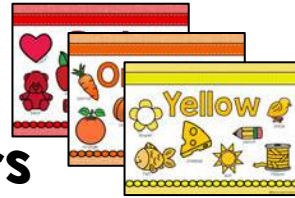

Day 1 Introduction - Colors

Talk about why colors are important. Take a poll on favorite colors and sing the "Color" song.

Introduction
Captivating Colors

Color is what our eyes see when light bounces off an object. Nature and the world around us are FULL of color.

Objectives:

- The students will notice similarities and differences and ask questions.
- The students will express themselves using words and sentences.
- The students will play with words, sounds, and rhymes.

Activities:

- Look at the real pictures with the students and notice the different colors. Ask questions like: "Can you see the green house? What are the red shapes on the balloon?"
- Take a poll: "What color do you like best?" Students use name cards or post-it notes to show their answer on a bar graph. Alternatively, they can make a physical graph by lining up behind the different headings.
- Sing the C-O-L-O-R song to the tune of "Stacy." Display the letters C-O-L-O-R and sing the song. After singing the first verse, cover up the letter O with a picture of the coloring circle. Sing the second verse as "C-O-L-O-R."

Extension Idea: Teach the ABC sign for "color" by moving your hand flat with your thumb tucked in. Then hold your hand left and right by the side of your body.

Day 1 lesson plans

Day 2 Primary Colors

Look at the real pictures. Search around the room for colors from the journal. Sort pictures into two groups.

Primary Colors
Red, Yellow, and Blue

Primary colors are red, blue, and yellow. These are the colors that create all other colors.

Objectives:

- The students will notice similarities and differences and ask questions.
- The students will observe objects with curiosity.
- The students will sort objects by color.

Activities:

- Show the pictures of the three primary colors and discuss where you see colors in the classroom and nature.
- Print out a journal for each student. Look around the classroom for different colors. Students check off the colors when they see them. Alternatively, print off the cards provided and hold them up for students to check off when they see them.

Extension Idea: Teach the ABC sign for "color" by moving your hand flat with your thumb tucked in. Then hold your hand left and right by the side of your body.

Day 2 lesson plans

Day 3 Secondary Colors

Examine the real pictures and sing a song. Play "Find the Missing Crayons!"

Secondary Colors
Orange, green, purple

Secondary colors are created when you mix red, blue, and yellow.

Objectives:

- The students will notice similarities and differences and ask questions.
- The students will follow oral directions.
- The students will identify shapes.

Activities:

- Examine the real pictures of the secondary colors. Engage in discussion questions by asking the students what else in nature could be these colors.
- Sing the song "What color are you wearing?" with students. Print the attached action cards and read them up when that color is called.
- Play the shape identification card game called, "Missing Crayons!"

Extension Idea: Teach the ABC sign for "color" by moving your hand flat with your thumb tucked in. Then hold your hand left and right by the side of your body.

Day 3 lesson plans

Day 4 Monochromatic

Explore the real pictures of black and white animals. Play "Animal Action" carpet game. Play black and white bingo.

Monochromatic
Black and White

Monochromatic describes something that has one color. Black and white animals are a great way to show monochromatic color.

Objectives:

- The students will notice similarities and differences and ask questions.
- The students will demonstrate basic locomotor skills.
- The students will follow oral directions.

Activities:

- Show the students the real pictures of black and white animals. Talk about the similarities and differences of the animals.
- Print out the Black and White Animal Action die. Out and in. Students take turns rolling the die and doing like the animals.

Extension Idea: Teach the ABC sign for "color" by moving your hand flat with your thumb tucked in. Then hold your hand left and right by the side of your body.

Day 4 lesson plans

Day 5 Rainbow

Check out the real picture of the rainbow. Sing the "Rainbow Song" then label the rainbow's colors.

Rainbow
Red, Orange, Yellow, Green, Blue, Purple

A rainbow happens when sun shines through tiny droplets of water in the sky and the light is bent (refracted) to create the different colors.

Objectives:

- The students will notice similarities and differences and ask questions.
- The children will play with words, sounds, and rhymes.
- The children will demonstrate an understanding of print concepts.

Activities:

- Show the real picture of the rainbow and ask if anyone has ever seen one. What colors do you see in the rainbow?
- Sing the Rainbow Song to the tune of "Twinkle, Twinkle."
- Label the different parts of the rainbow. Copy off the black and white template and have students color it and trace the words.

Extension Idea: Teach how to sign rainbow in ASL by moving one hand up to an arm, then down towards the other side of your body. 23 rocks like your fingers are the ends of the rainbow.

Day 5 lesson plans

Circle Time Lessons

Unit overview

Day 6 Mixing

Inspect the real pictures of paint. Sing “Mix it Together”. Play the carpet game “Mouse in the House”.

Day 7 Shade

Look at the real pictures of color shades. Chant the “Shade” poem. Play the grid game.

Day 8 Changing Colors

Survey the real pictures of the chameleons. Recite the “Chameleon on a Log” chip clip poem. Read “I See a Chameleon!”

Day 9 Festival of Colors

Investigate the real pictures of Holi festivities. Sing and dance to “Holi, Holi Dance” then guess what colors are in the box.

Day 10 Conclusion

Practice active listening skills by solving these riddles about colors. Take a class poll.

Mixing

Creating new colors

Mixing colors together can create new colors. It all starts with the primary colors: red, yellow, and blue.

Objectives:

- The students will notice similarities and differences and ask questions.
- The students will share and take turns with others.
- The students will follow oral directions.

Activities:

- Examine the real pictures with the students. Point out the red paint under the artist's hand and then the blue paint on the palette. Talk about what color was made and what colors will be made.
- Play the carpet game – Mouse in the House. Copy the colored houses or use the back and white template to copy on to your own colored construction paper. Write the students cover their eyes, hide the mouse under a house. Then chant the poem and choose someone to guess what color house the mouse is under. Sing “Mix It Together”. Fold the card pages in half. Show the two color side first, then the mixed color side as you sing.

Extension Idea: Check out the bread recipe for representing primary. Use the colored color construction paper to make a basket for the children to take home ingredients.

Day 6 lesson plans



Shade

Lighter and Darker

Different shades of a color can be made by adding white or black. Gray can be made by adding a little black to white. Tan can be made by adding a little brown to white.

Objectives:

- The students will notice similarities and differences and ask questions.
- The students will play with words, sounds, and rhythms.
- The students will notice and extend simple patterns.

Activities:

- Examine the photo posters with shade. Talk about how the colors get lighter when white is added.
- Start a fun shade chant with the students. Fold the print pages in half and have them guess what the opposite will be. Grid Game: Trace these as they are different colors.

Day 7 lesson plans

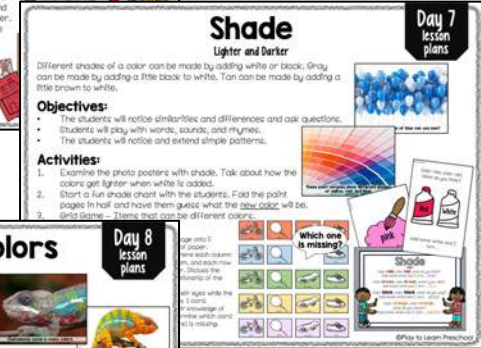

Changing Colors

Chameleon

The chameleon is a lizard that is able to change colors. They change colors so they can hide from predators.

Objectives:

- The students will notice similarities and differences and ask questions.
- The students will count down from five.
- The students will demonstrate an understanding of print concepts.

Activities:

- Examine the real photos of chameleons. Talk about the different colors that are seen.
- Chip clip “Chameleon on a Log”.
- Practice concept of word – “I See a Chameleon”.

Act each of the sentences to the pocket chart. Act the picture cards to help emergent readers remember each line.

Extension Idea: Teach the ABC sign for “chameleon” by having them stretch and holding them near your eyes. The sign reminds the shape of the chameleon's eyes.

Day 8 lesson plans



Festival of Colors

Holi Celebration

Some people celebrate Holi (holi) at the end of winter and beginning of spring. They sing, dance, eat gummy foods, and throw brightly colored powders in the air. The colors are beautiful!

Objectives:

- The students will use new vocabulary.
- The students will demonstrate basic locomotor skills.
- The students will share and take turns with others.

Activities:

- Examine the real photos of Holi. Ask if anyone has ever participated in the celebration. What color powder do they like best?
- Recite the Holi, Holi Dance. Use the cards to show what step is next.

Day 9 lesson plans



Conclusion

Unit Conclusion

To conclude the unit, ask the students to describe what they have learned about colors. Is their favorite color the same as when the unit started?

Objectives:

- The students will express themselves using words and sentences.
- The students will interact and participate in group time.

Activities:

- Invite students to fit the things they have learned about colors. Write the ideas on index cards or on the orange box tags provided.
- Create riddle tags. Place a small colored toy (or star card provided) in each bag and affix the coordinating riddle to the outside of the bag. Read the riddle while the students practice their active listening skills. They guess what color is in the bag, then check inside!

Extension Idea: Use eye droppers and colored water to explore color theory.

Day 10 lesson plans

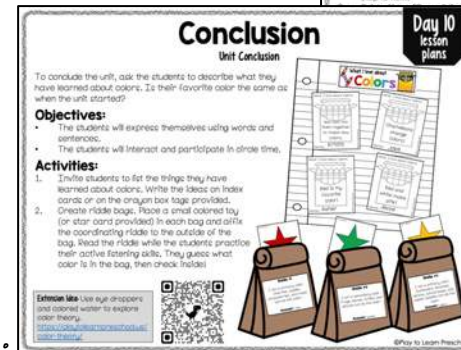



heart

Red

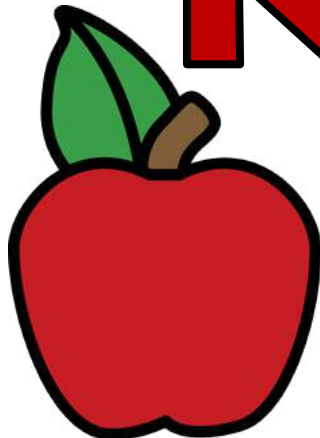

apple

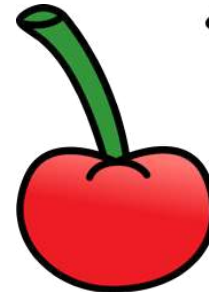

cherry



bow

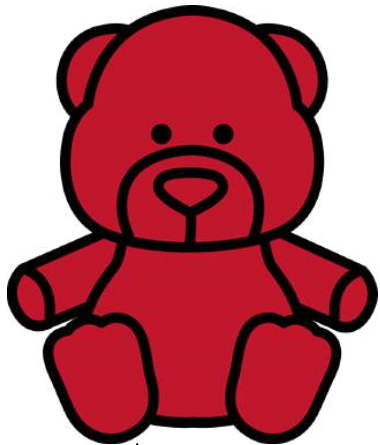

bear



umbrella



crayon

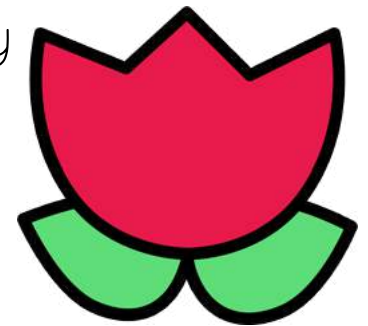

flower

Orange



carrot



pumpkin

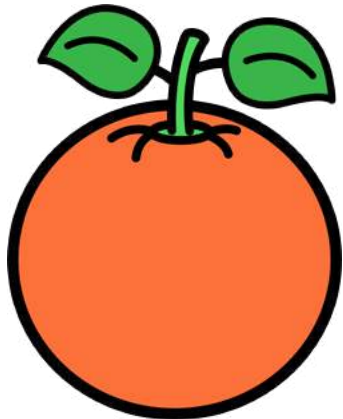

orange



tiger

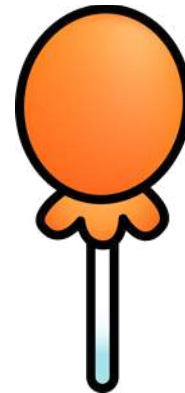

lollipop



colored pencil



orange juice

Yellow

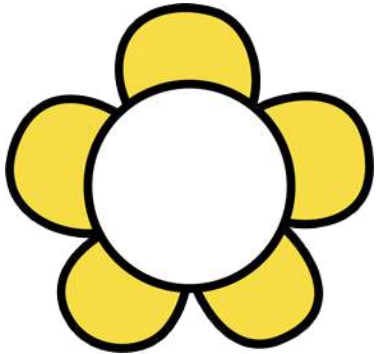

flower

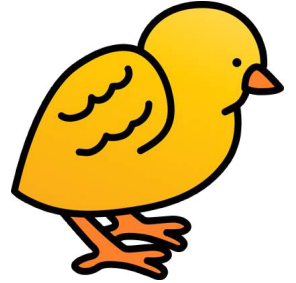

chick

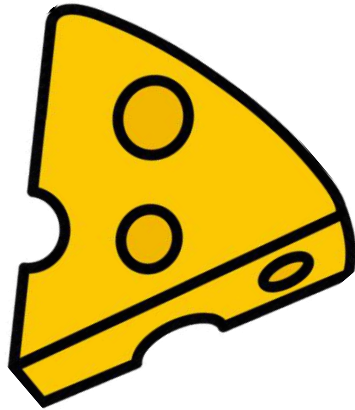

cheese

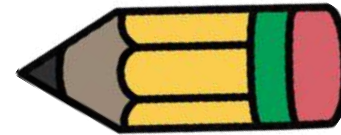

pencil

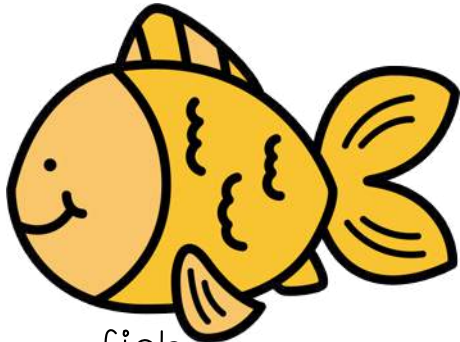

fish

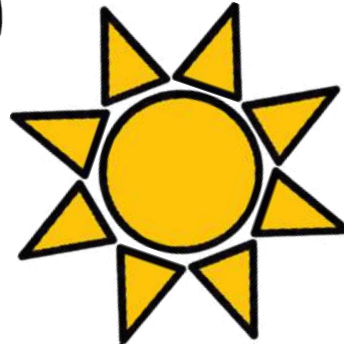

sun



ribbon

Green



tree

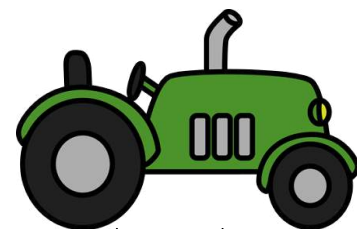

tractor



hat



shamrock

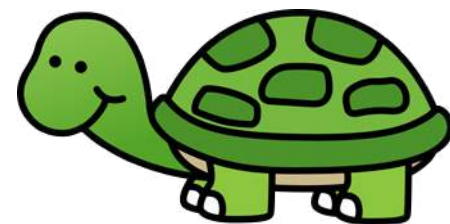

turtle



crayon



wheel barrow



car



shoe

Blue



rain



butterfly

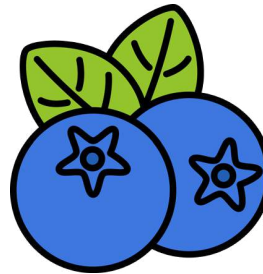

blueberries

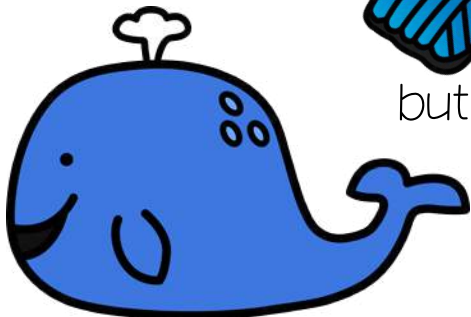

whale

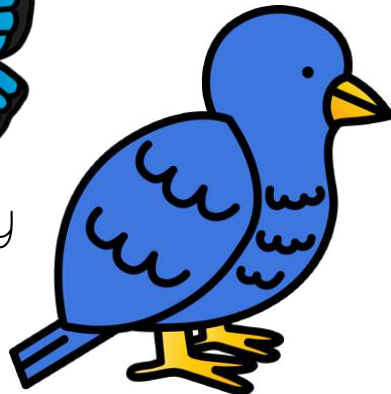

blue bird

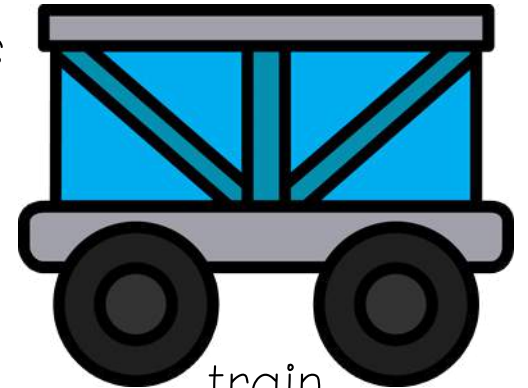

train

Purple



grapes



jelly

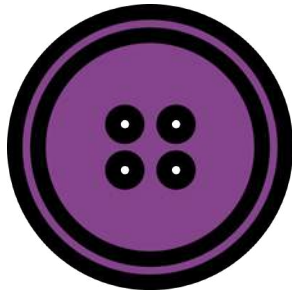

button

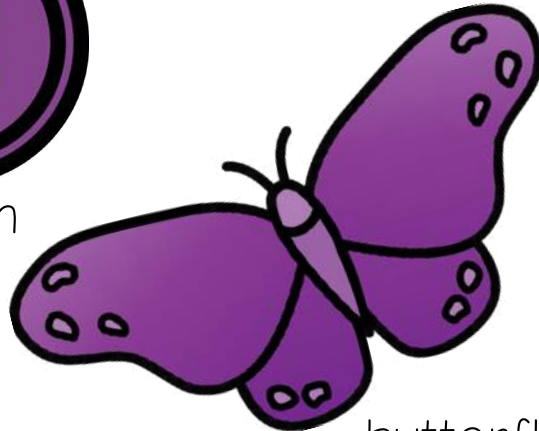

butterfly

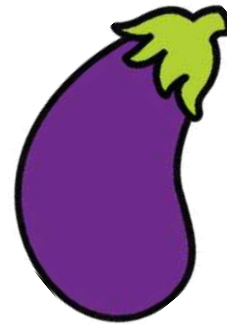

eggplant

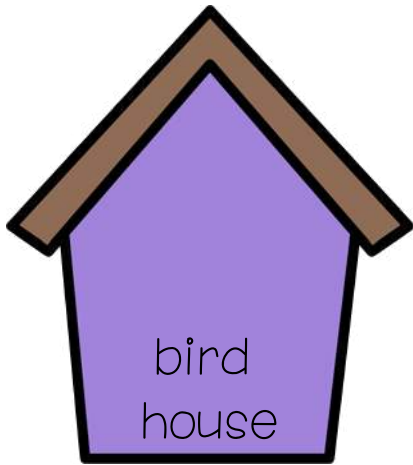

bird
house

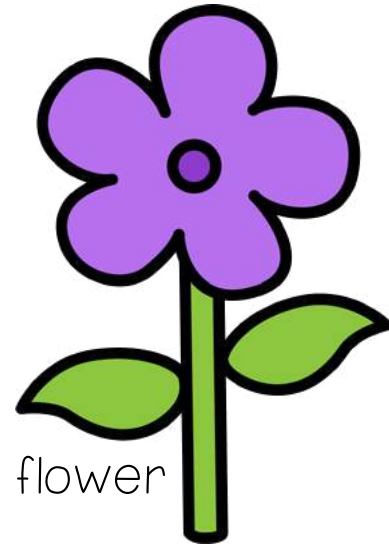

flower



butterfly

Pink



flamingo

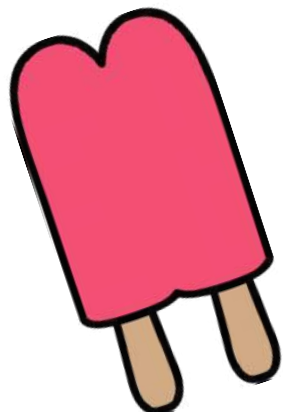

popsicle

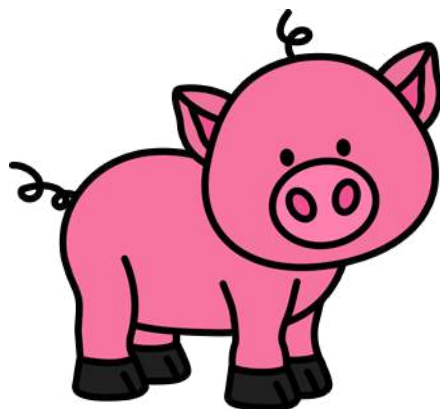

pig



flower



bubble gum



cotton
candy

Brown

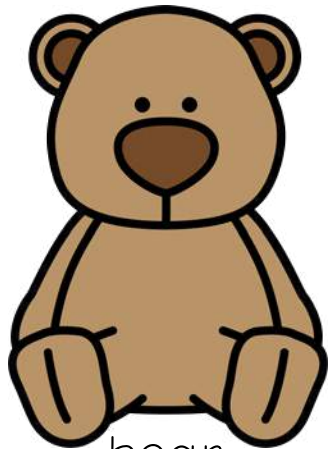

bear



boot

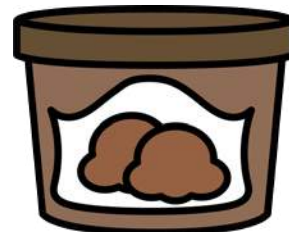

ice cream

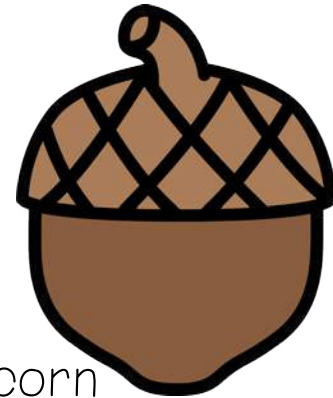

acorn

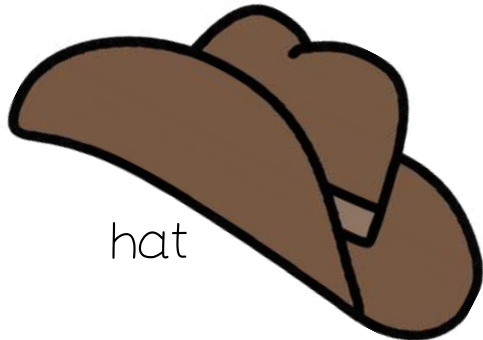

hat



leaf

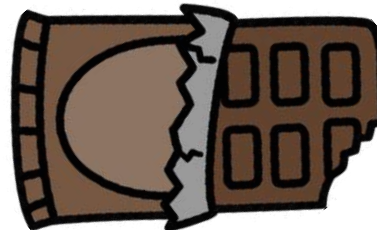

chocolate

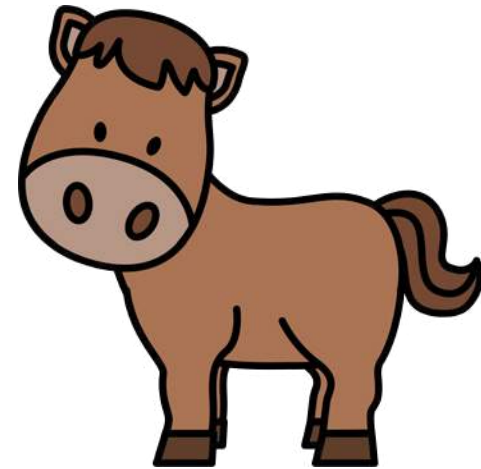

horse

Black

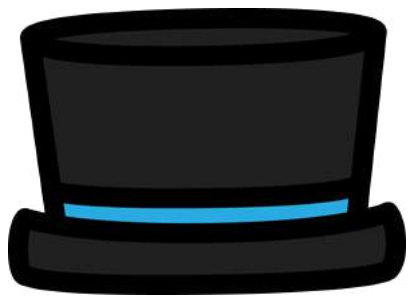

hat



bat



phone

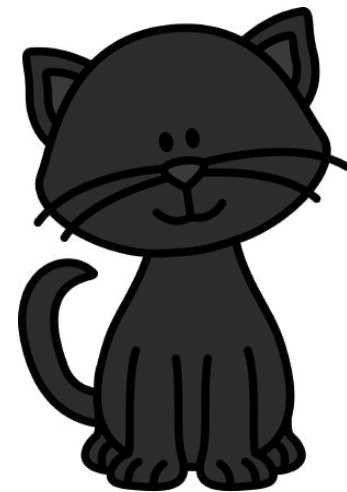

cat



sheep



skunk



crayon

Gray

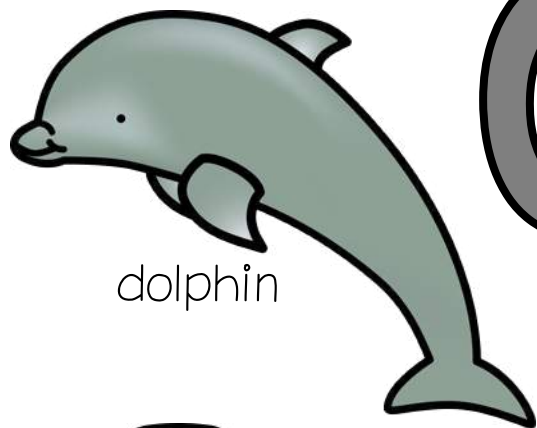

dolphin

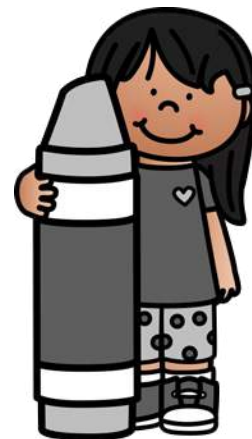

crayon



storm cloud

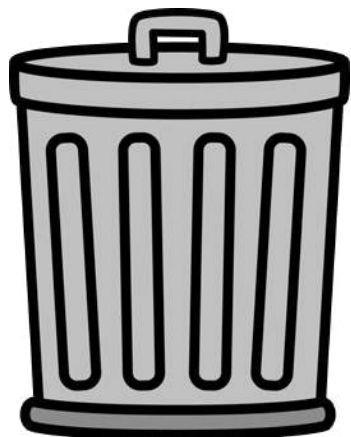

garbage can



mouse

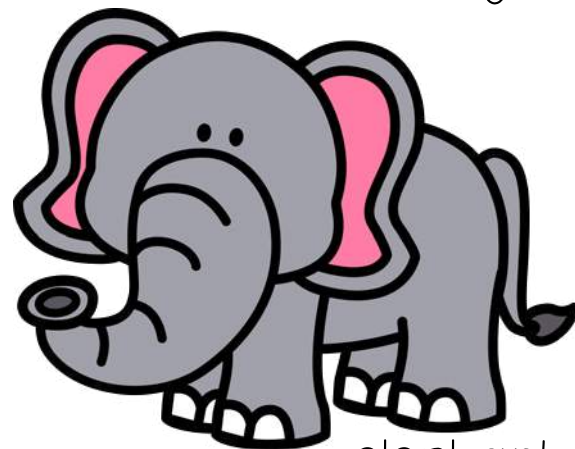

elephant





snowman

White



mitten

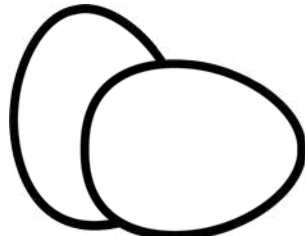

eggs



sheep

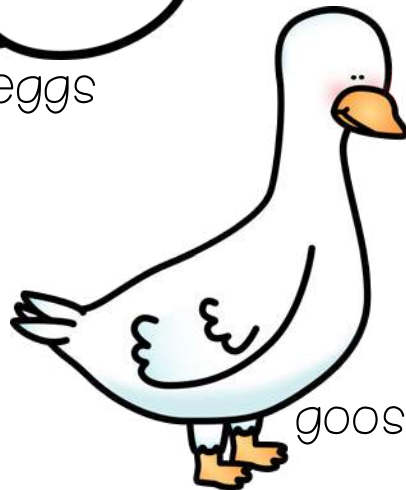

goose



milk

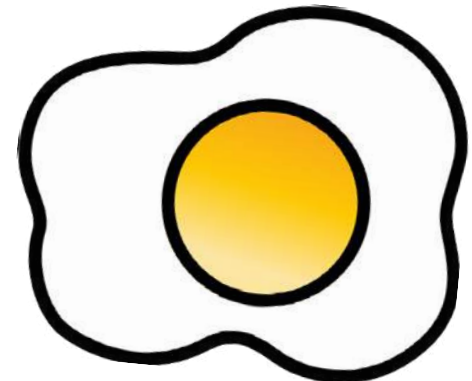

egg white

Introduction

Captivating Colors

Day 1
Lesson
Plans

Color is what our eyes see when light bounces off an object. Nature and the world around us are FULL of colors.

Objectives:

- The students will notice similarities and differences and ask questions.
- The students will express themselves using words and sentences.
- The students will play with words, sounds, and rhymes.

Activities:

1. Look at the real pictures with the students and notice the different colors. Ask questions like: "Can you see the green house? What are the red shapes on the balloon?"
2. Take a poll: "What color do you like best?"
Students use name cards or post-it notes to show their answer on a bar graph. Alternatively, they can make a physical graph by lining up behind the different headings.
3. Sing the C-O-L-O-R song to the tune of "Bingo." Display the letters C-O-L-O-R and sing the song. After singing the first verse, cover up the letter C with a picture of the clapping child. Sing the second verse as "clap, O-L-O-R."

Extension Idea: Teach the ASL sign for "blue" by making your hand flat with your thumb tucked in. Then twist your hand left and right by the side of your body. (x2)



Which color do you like best?

©Play to Learn Preschool

 I like red.	 I like yellow.	 I like blue.	 I like green.
Carol	Dave	Deven	Frank
		Jean	Mary



**Colors help us see the differences
in the space around us.**



These beautiful hot air balloons look different because of their color and designs.

Which color do you like best?

©Play to Learn Preschool

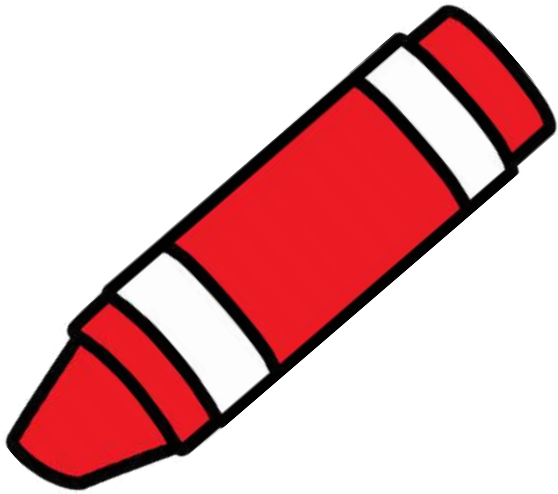

I like
red.

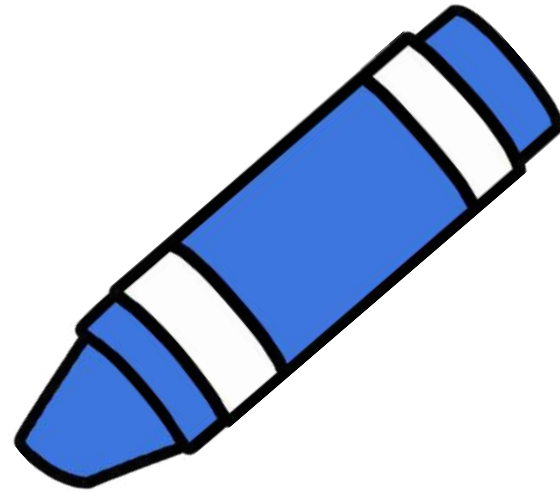

I like
blue.

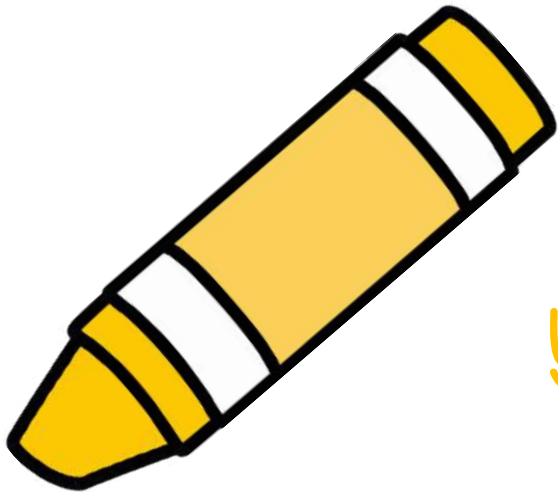

I like
yellow.

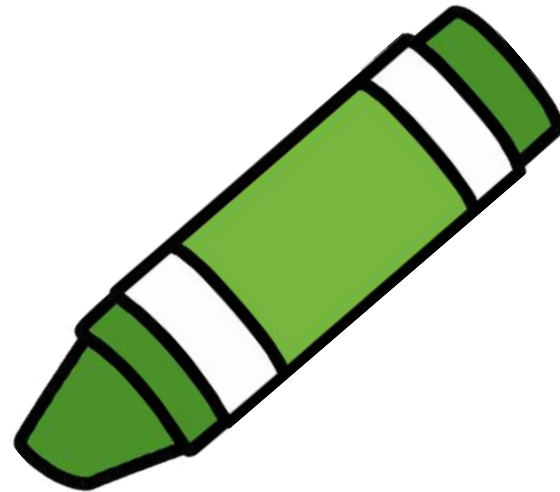

I like
green.

Which color do you like best?

©Play to Learn Preschool

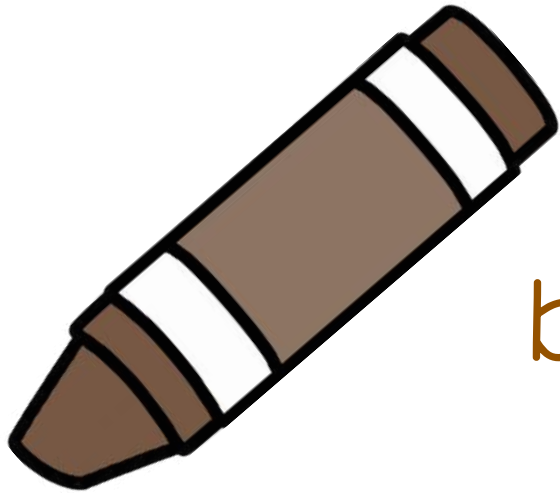

I like
brown.

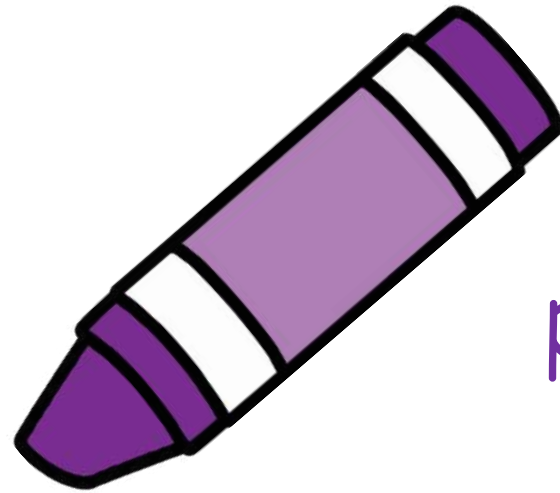

I like
purple.

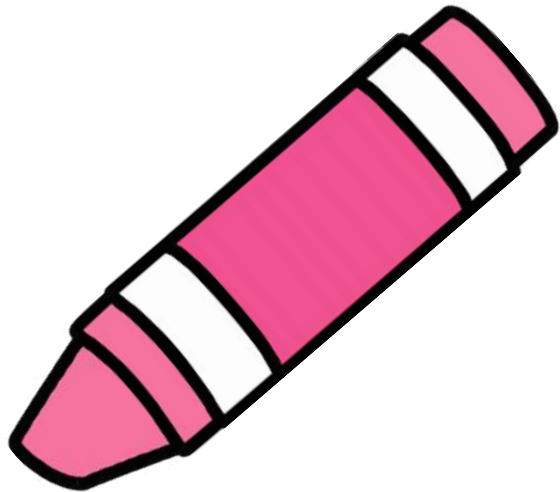

I like
pink.



I like
orange.

COLOR

To the tune of "Bingo"

I fill the world
with sights to see with
red and **blue** and **yellow**.

C-O-L-O-R

C-O-L-O-R

C-O-L-O-R

And color is my name-o.

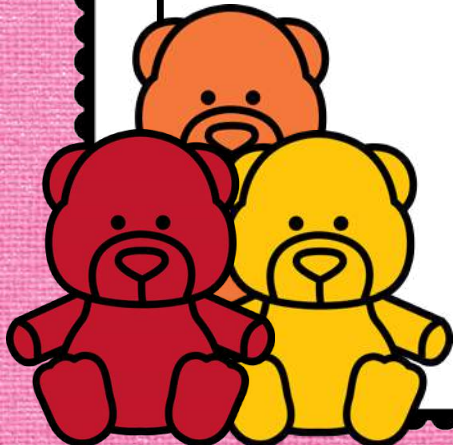





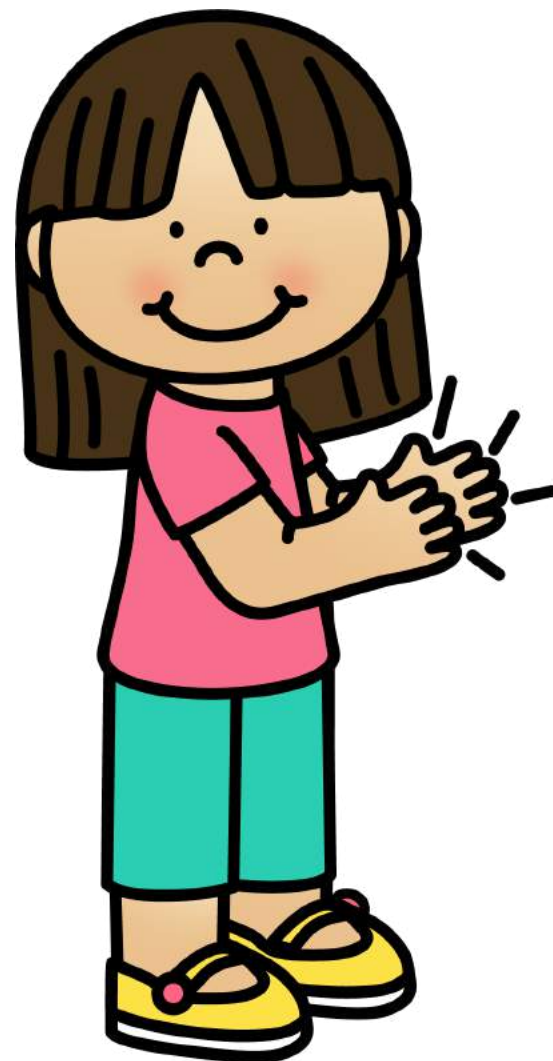

Clap!



Clap!

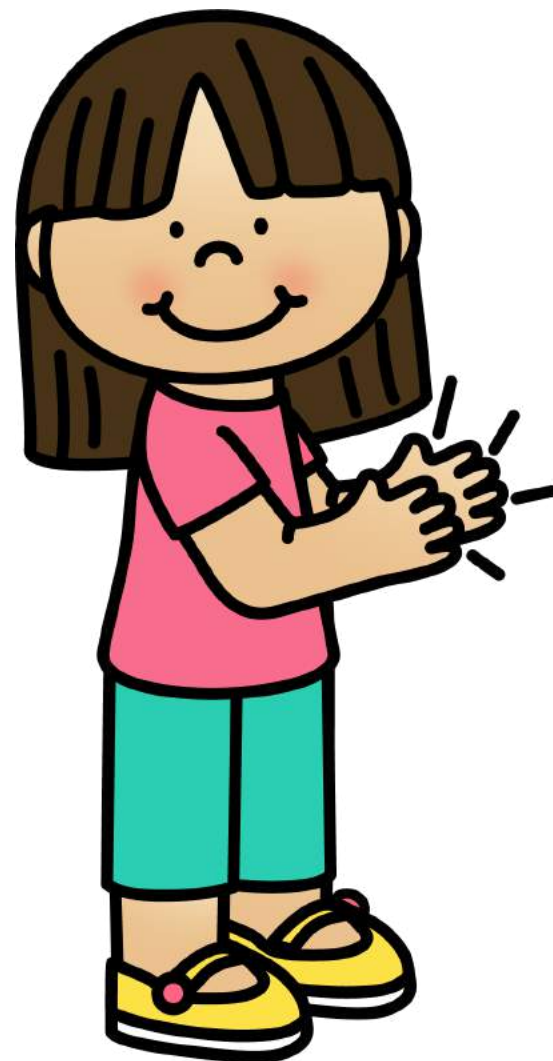

Clap!



Clap!

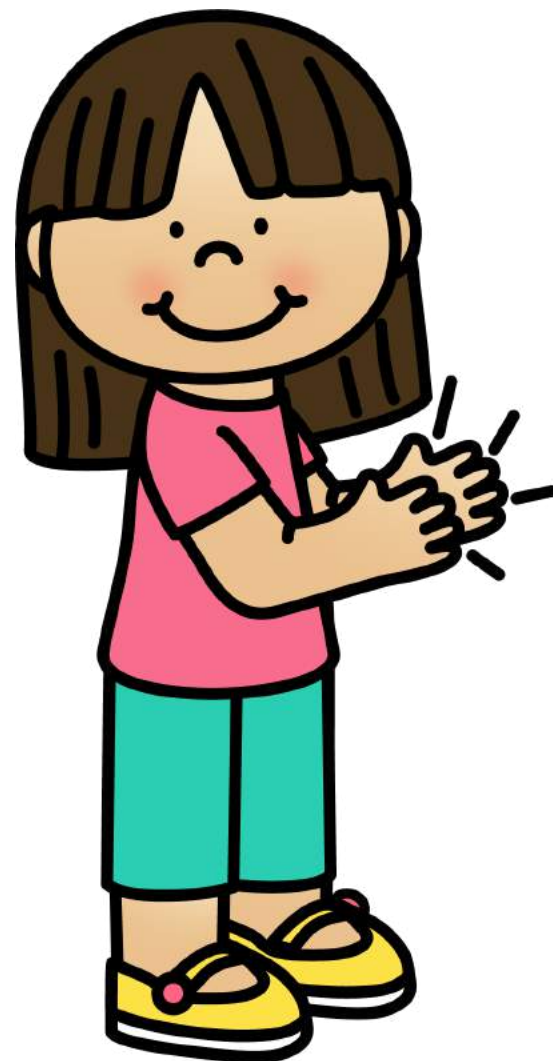

Clap!

Primary Colors

Red, Yellow, and Blue

Day 2
lesson
plans

Primary colors are red, blue, and yellow. These are the colors that create all other colors.

Objectives:

- The students will notice similarities and differences and ask questions.
- The students will observe objects with curiosity.
- The students will sort objects by color.

Activities:

1. Show the pictures of the three primary colors and discuss where you see colors in the classroom and nature.
2. Print out a journal for each student. Look around the classroom for different colors. Students check off the colors when they see them. Alternatively, print off the cards provided and hold them up for students to check off when they recognize the color.
3. Sort the pictures into 2 groups: Primary Colors vs. Not Primary Colors

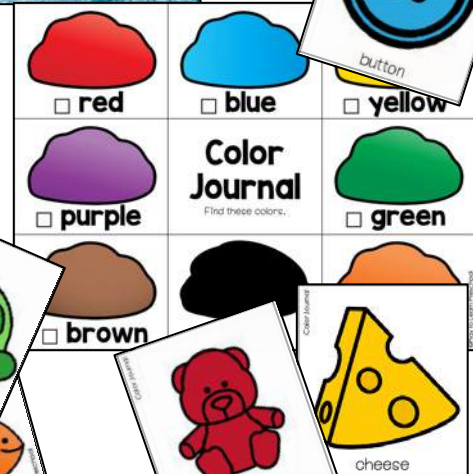
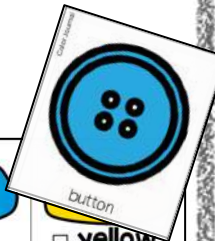

Extension Idea: Teach the ASL for "red". Take your pointer finger and place it just below your bottom lip. Draw your finger down to the tip of your chin.

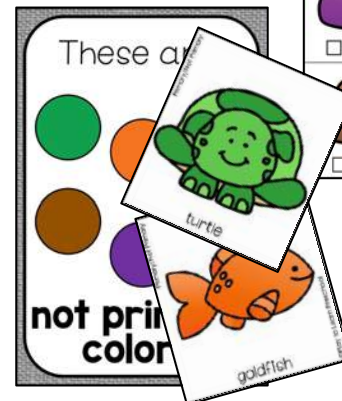
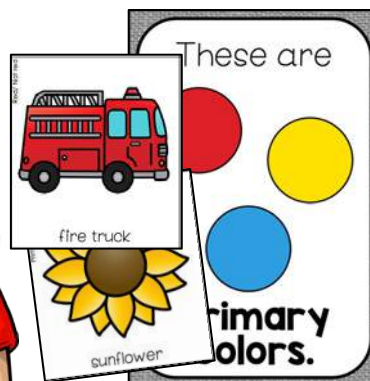



This rose is red .



The ocean has beautiful colors of **blue**.



**We know the corn is ready to eat because
of its beautiful yellow color.**

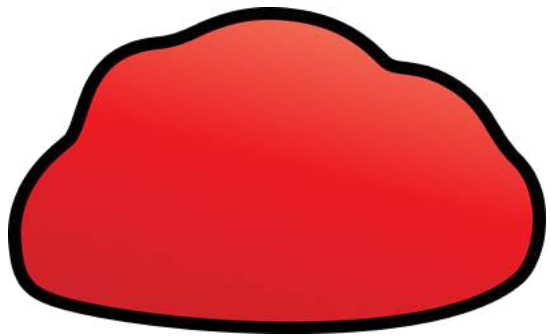

red

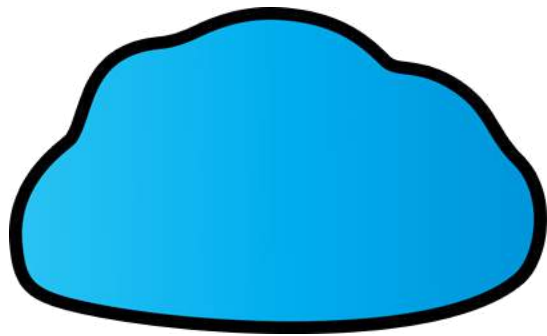

blue

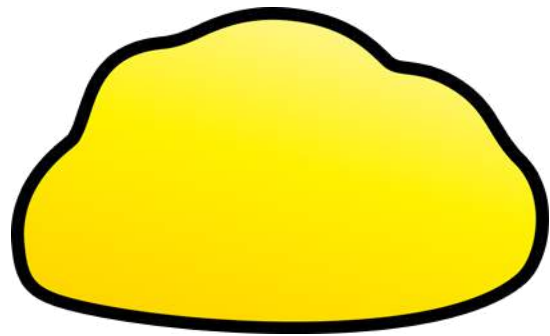

yellow

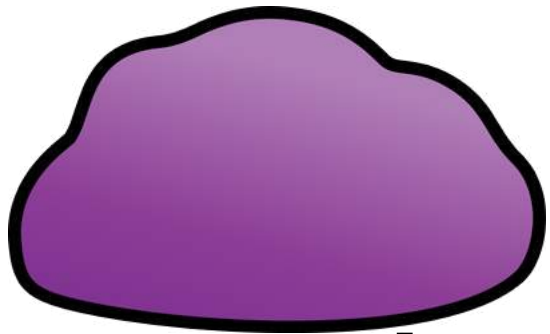

purple

Color Journal

Find these colors.

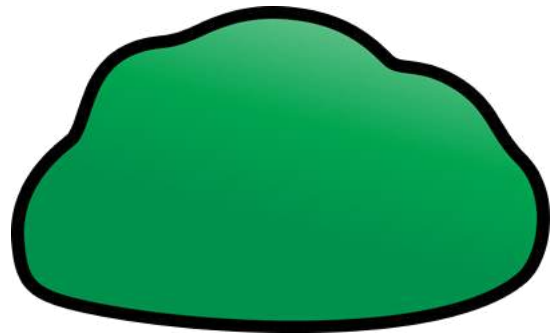

green

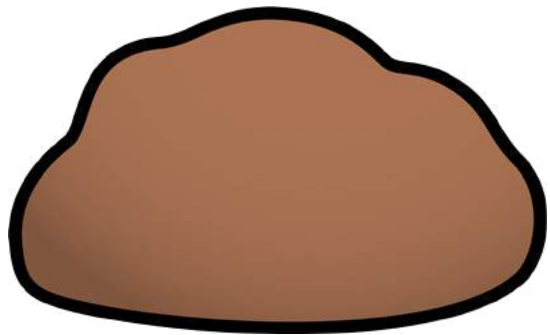

brown

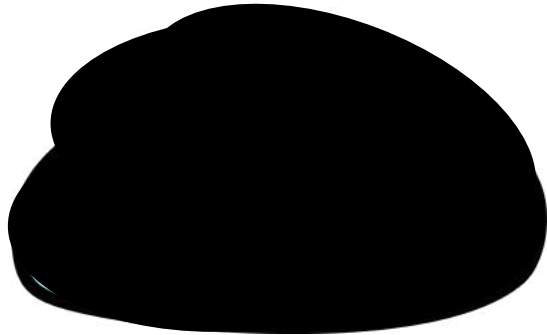

black

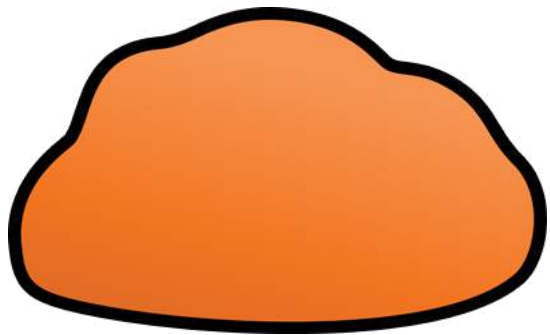

orange

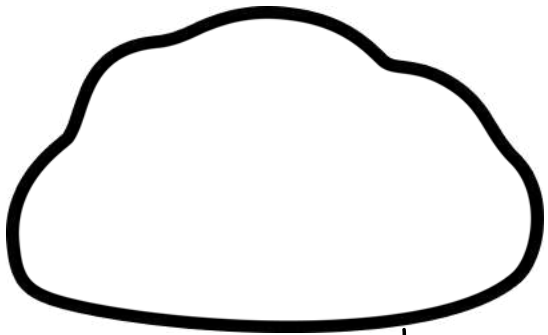

red

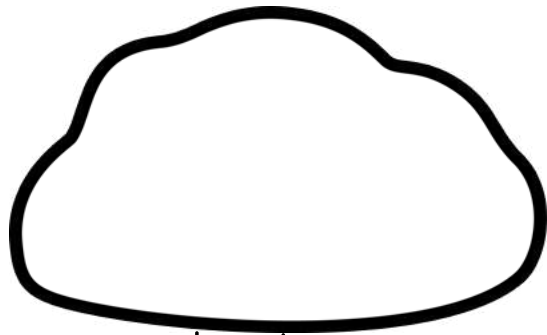

blue

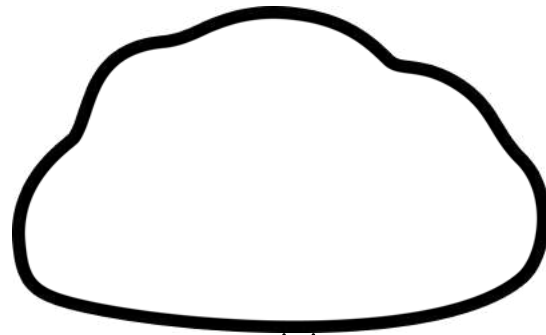

yellow

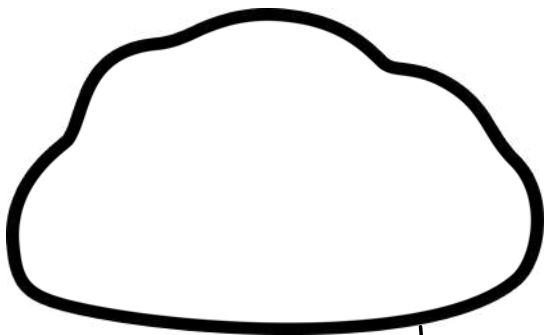

purple

Color Journal

Find these colors.

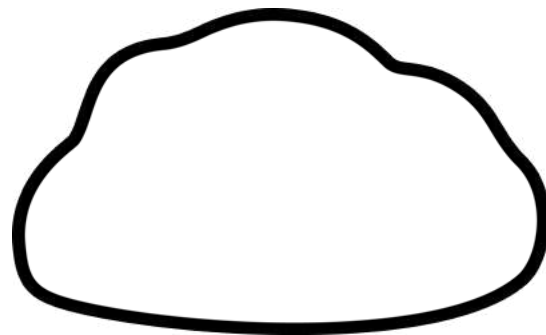

green

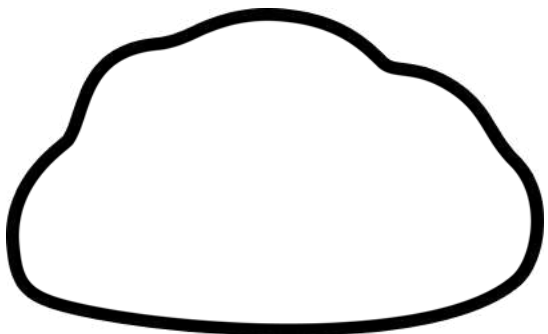

brown

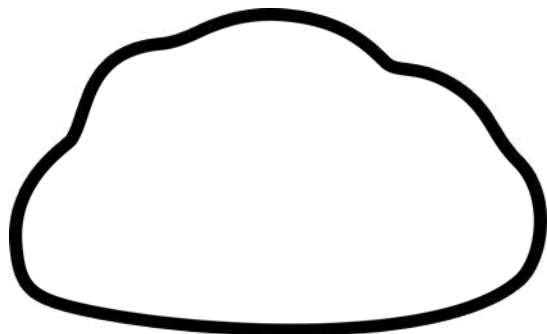

black

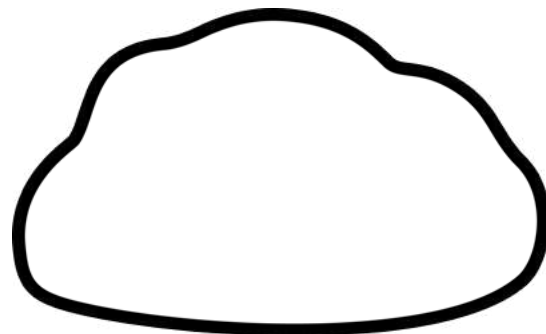

orange

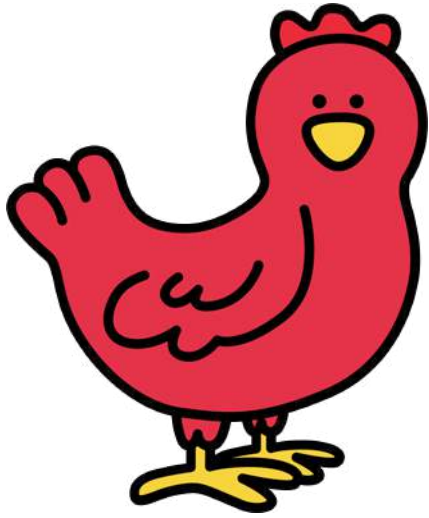

hen

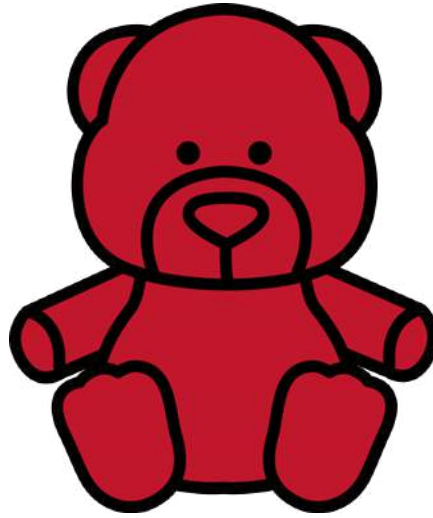

bear



wagon



pumpkin

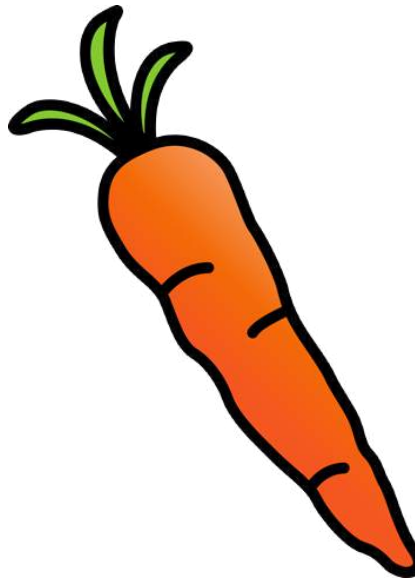

carrot

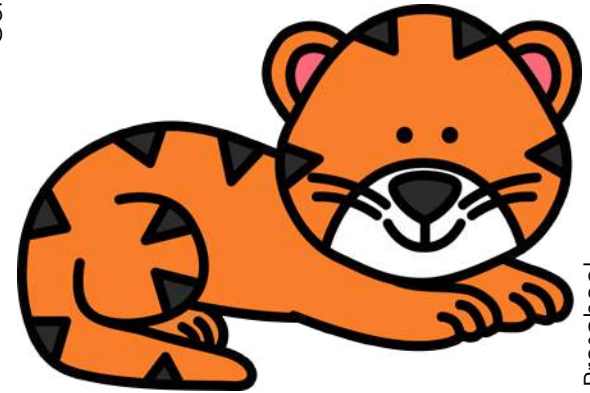

tiger

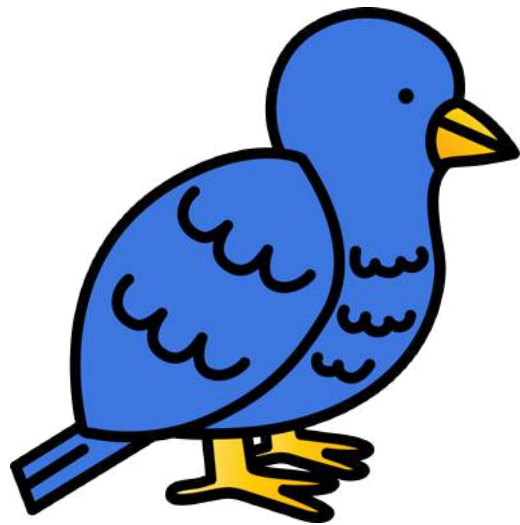

bird

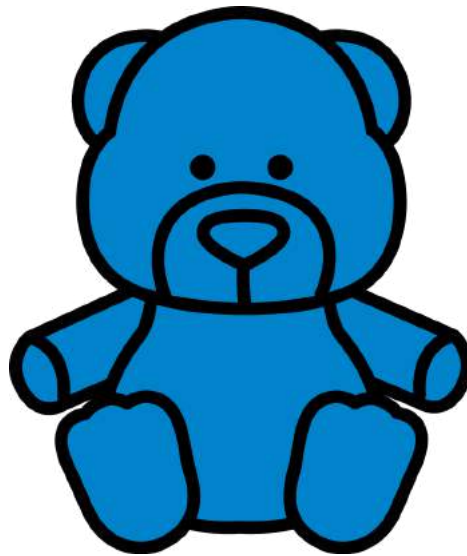

bear

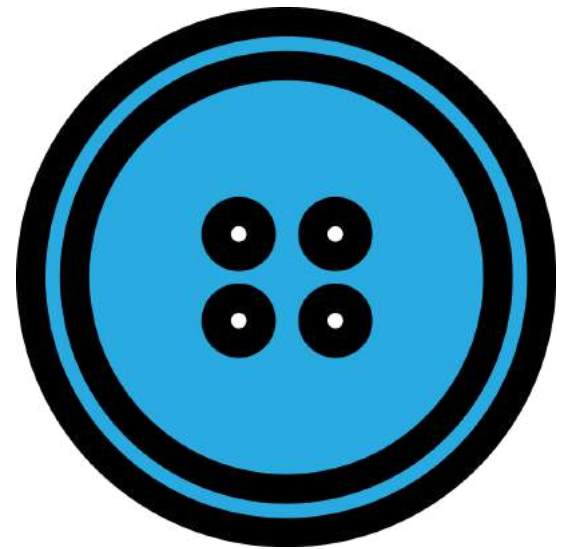

button

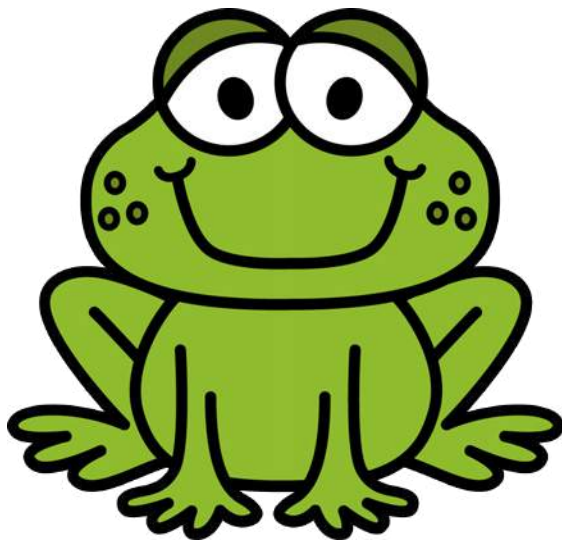

frog

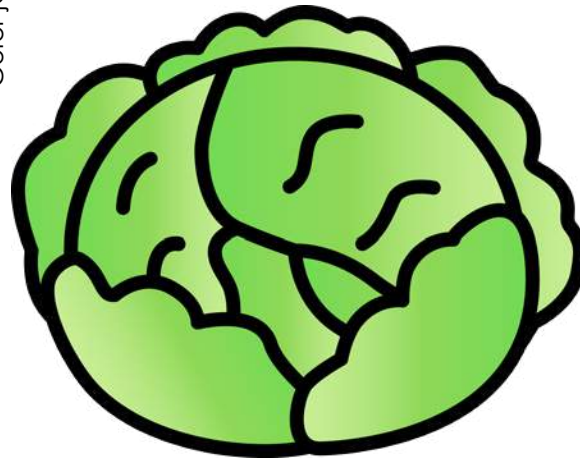

lettuce

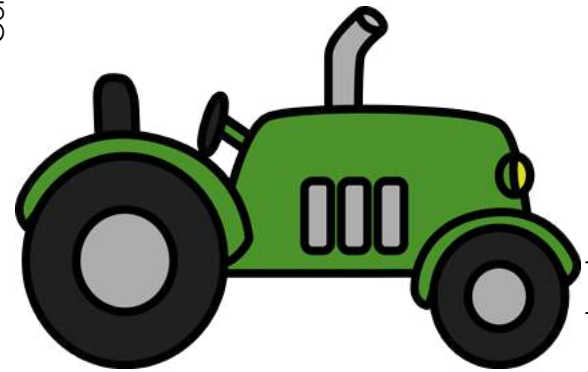

tractor

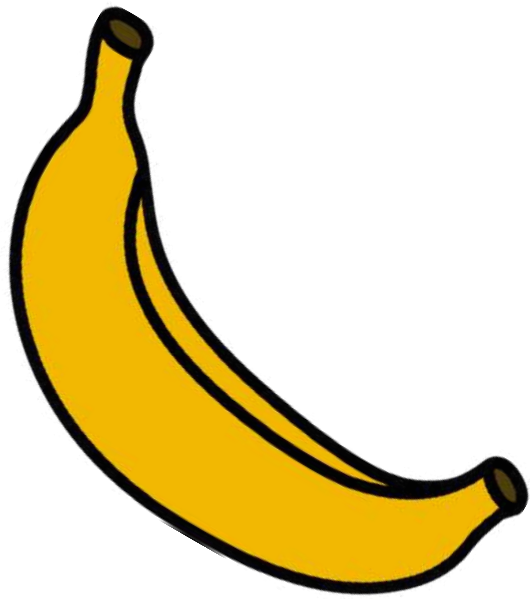

banana

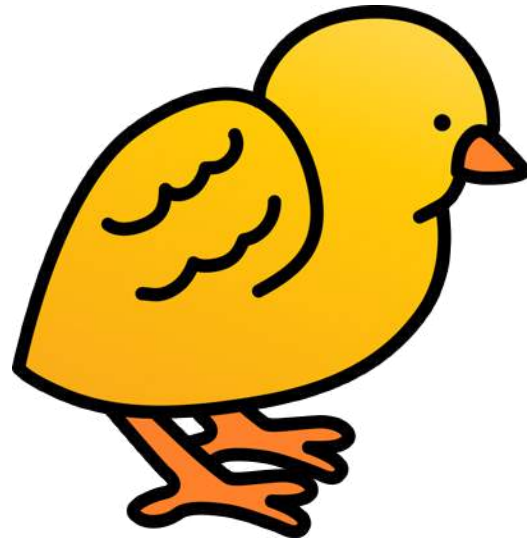

chick

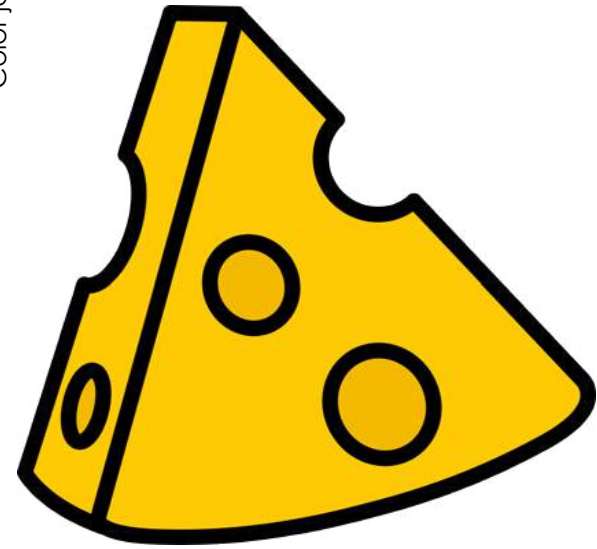

cheese

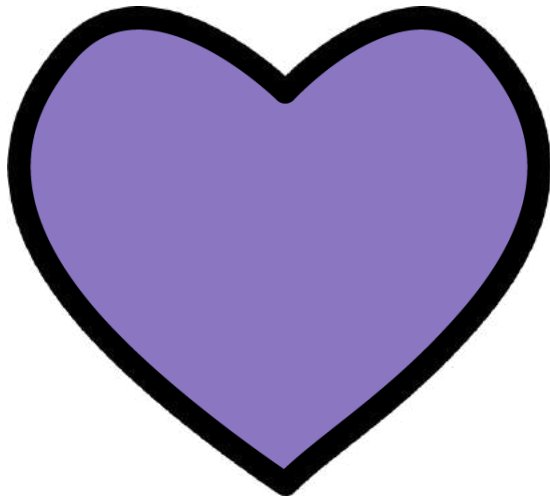

heart



flower

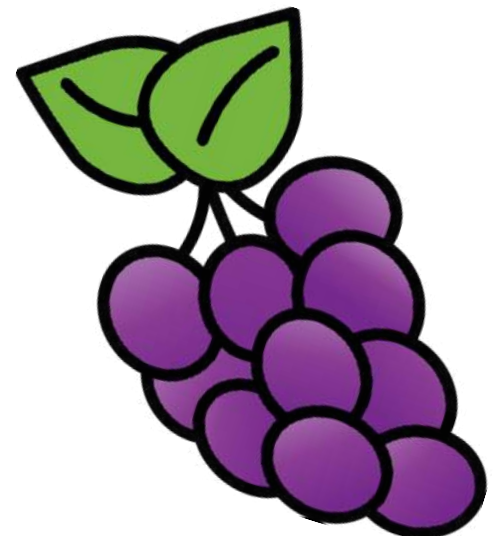

grapes

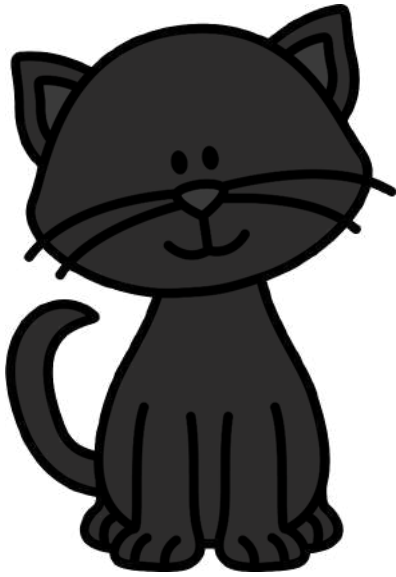

cat

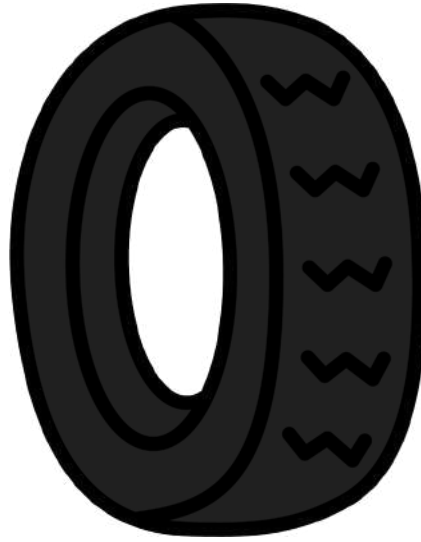

tire

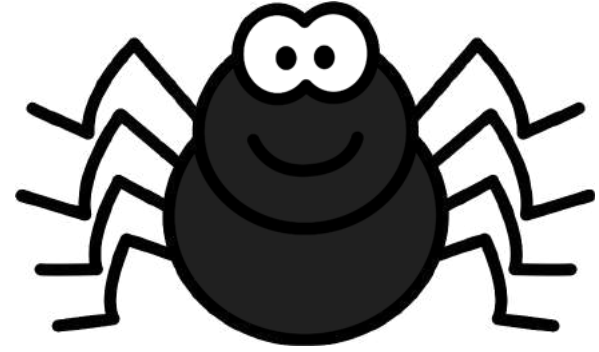

spider

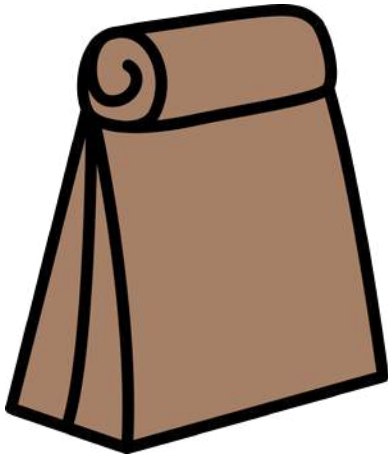

bag



chocolate

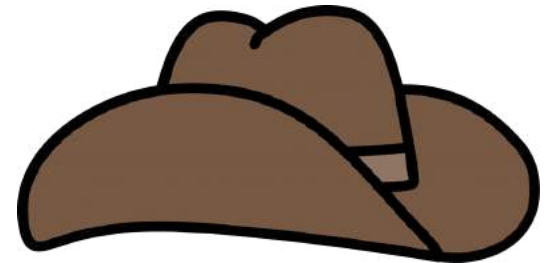

hat

These are

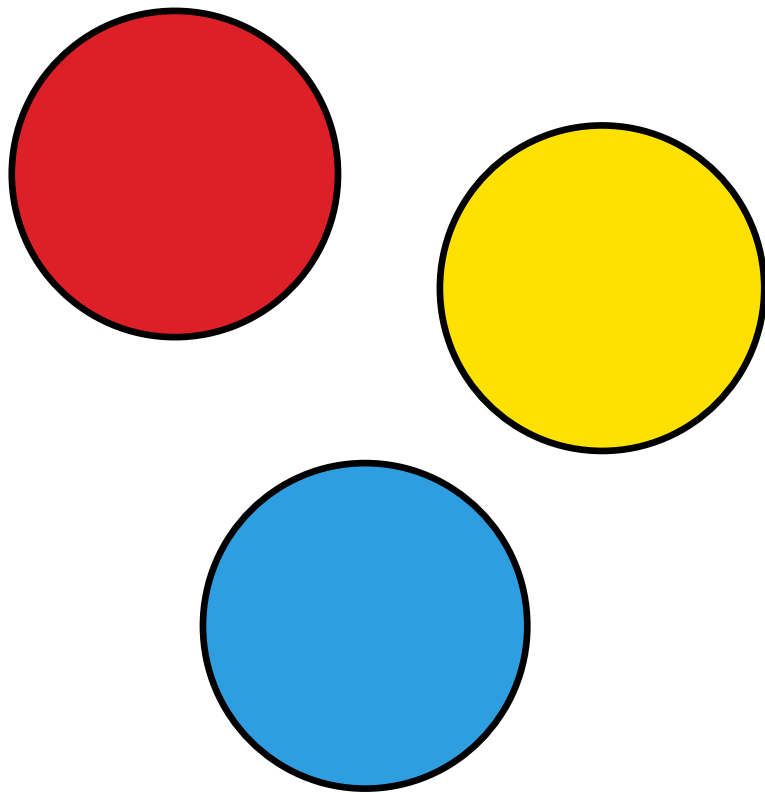

**primary
colors.**

These are

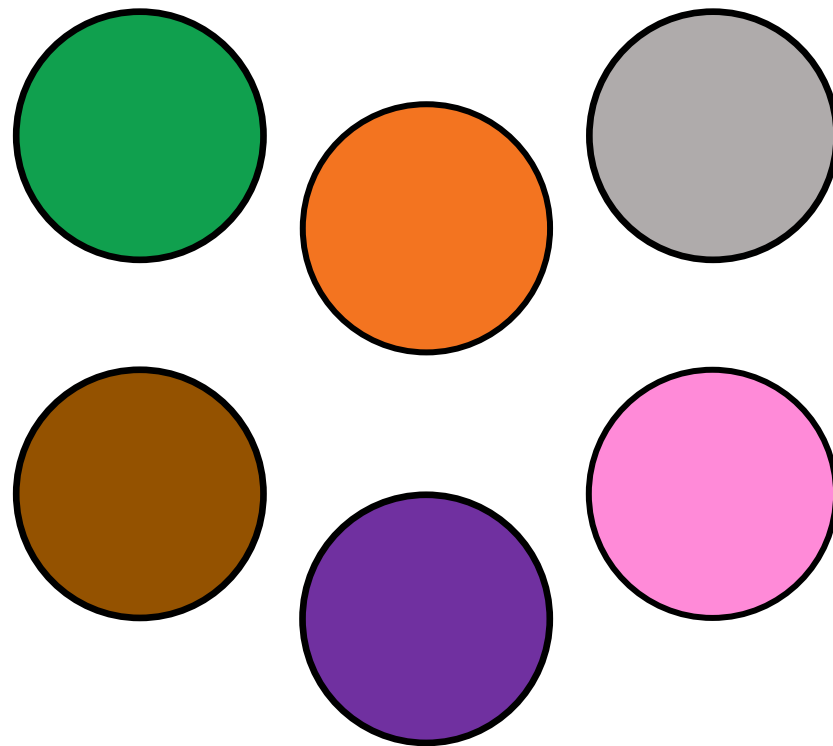

**not primary
colors.**

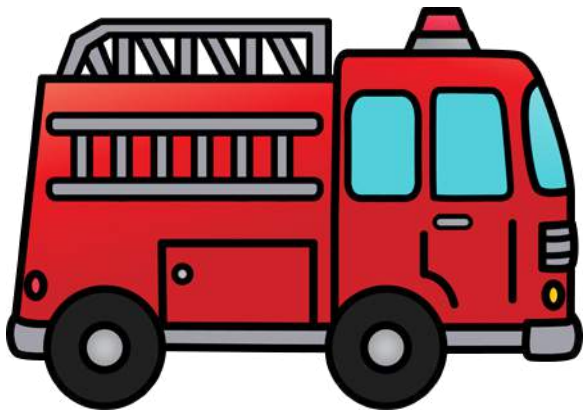

fire truck

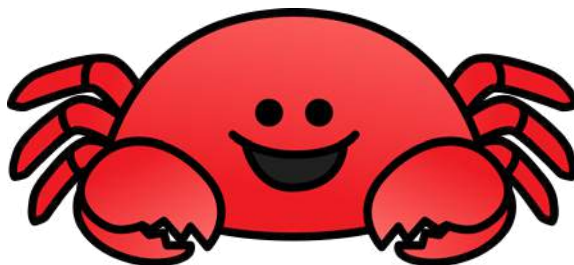

crab



fire hydrant

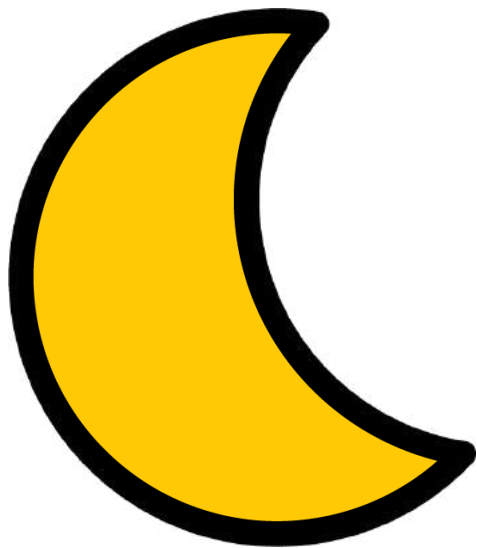

moon

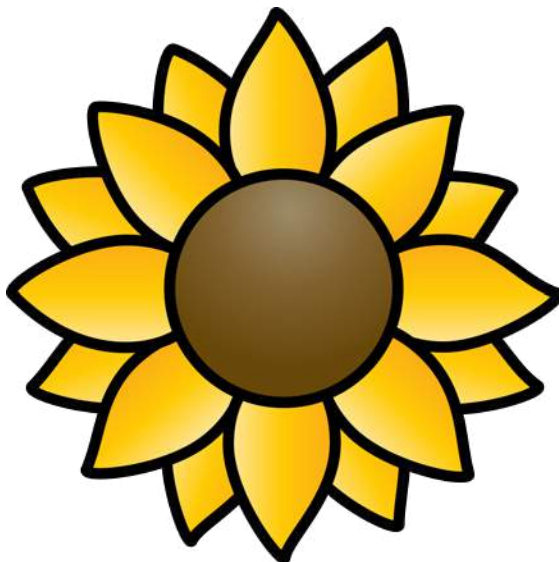

sunflower



bus

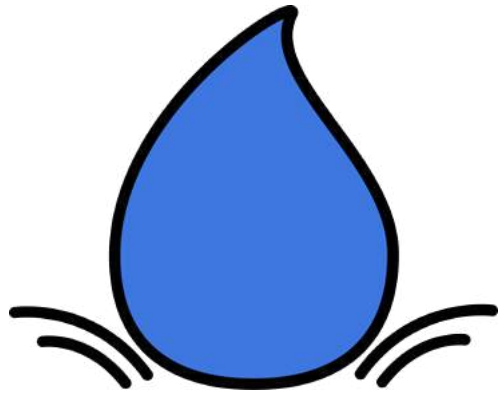

raindrop

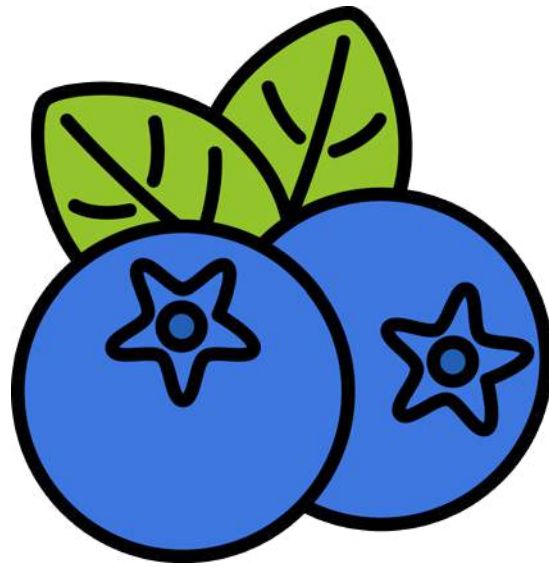

blueberries



butterfly

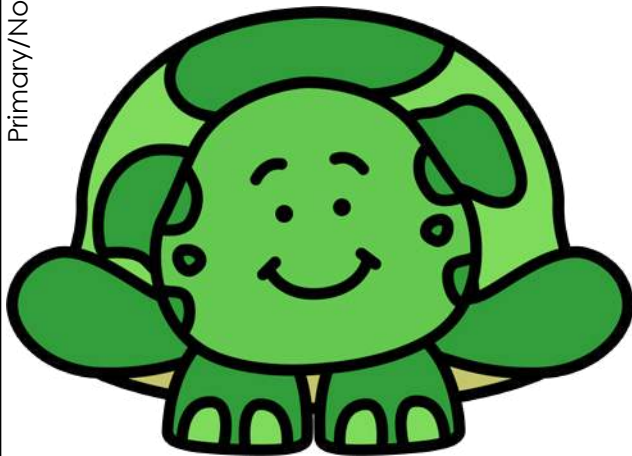

turtle



snowman



shoes

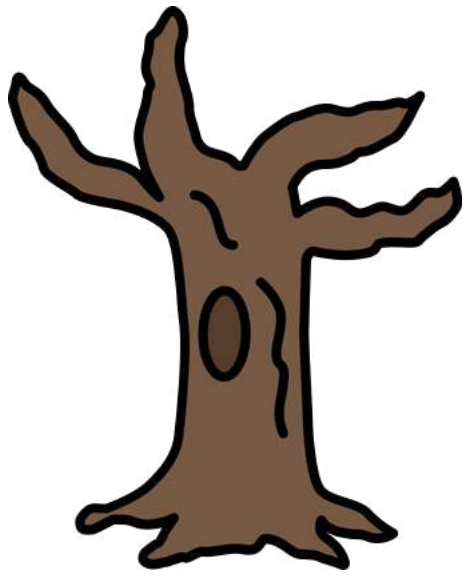

tree trunk

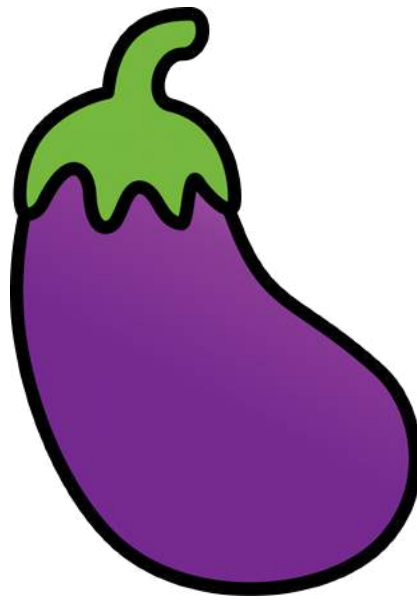

eggplant



tire

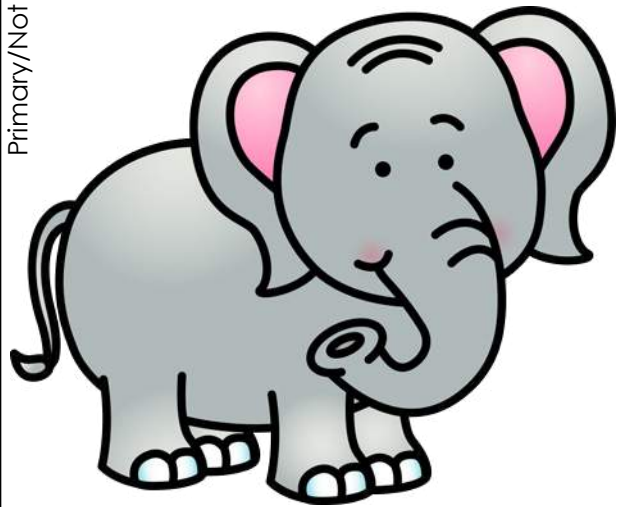

elephant

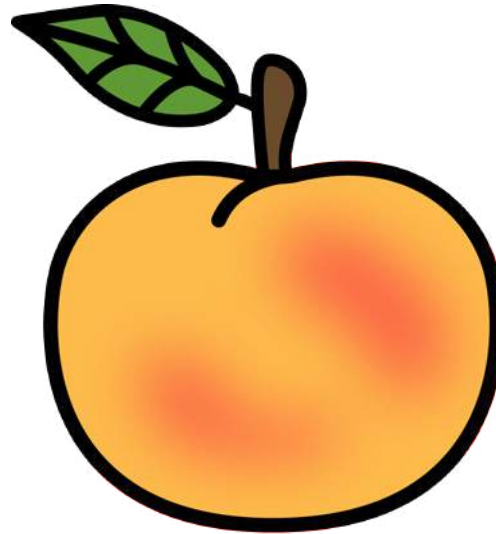

peach

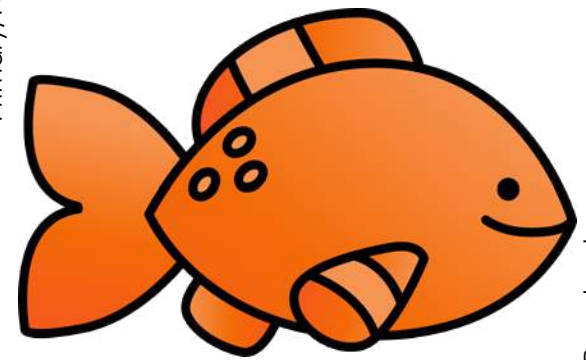

goldfish

Secondary Colors

Orange, green, purple

Day 3
lesson
plans

Secondary colors are created when you mix red, blue, and yellow.

Objectives:

- The students will notice similarities and differences and ask questions.
- The students will follow oral directions.
- The students will identify shapes.

Activities:

1. Examine the real pictures of the secondary colors. Engage in discussion questions by asking the students what else in nature could be these colors.
2. Sing the song "What color are you wearing?" with students. Print the attached action cards and hold them up when that color is called.
3. Play the shape identification carpet game called, "Missing Crayons!"



Extension Idea: Teach the ASL sign for "yellow" by making a fist with the thumb and pinkie finger extended (the ASL sign for 'U'), then twist the hand back and forth.





Green is all around us at the park.



Purple flowers fill this lavender field.



Orange pumpkins remind us of fall.

What Color are You Wearing?

To the Tune of "The Muffin Man"

If you have
a green shirt on,
a green shirt on,
a green shirt on.

If you have
a green shirt on,
stand up and
say hello!!

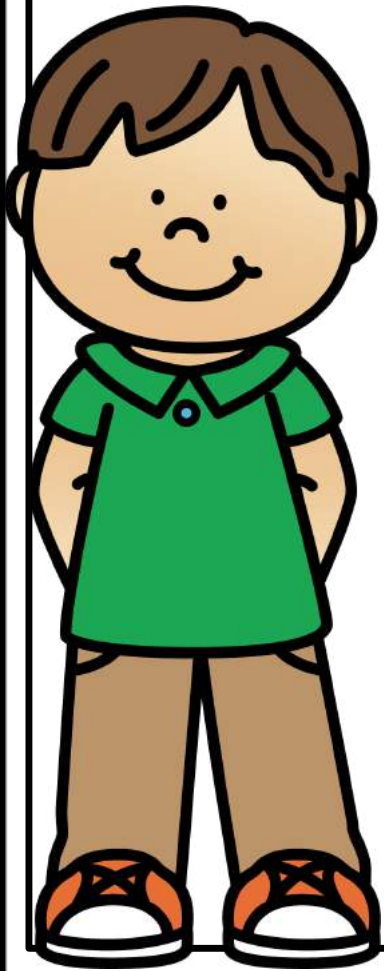

Pink – clap your hands
Blue – stomp your feet
Yellow – jump up and shout hooray
Red – stretch your shoulders
Purple – pat your belly
Orange – stand up and stretch your arms
Black – pat your hips and smile

What Color are you Wearing?

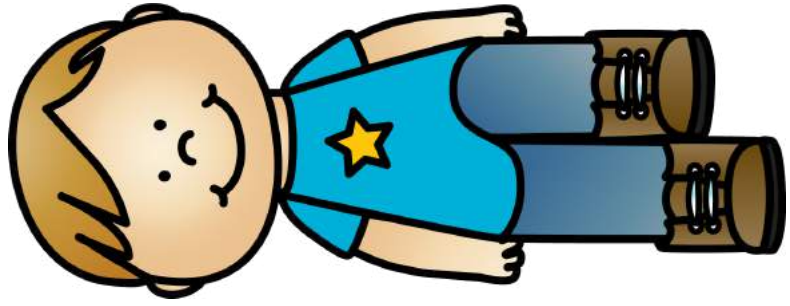

blue stomp feet

What Color are you Wearing?

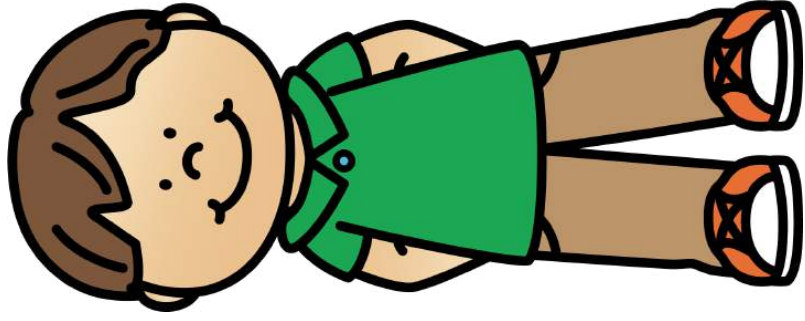

green say "hello"

What Color are you Wearing?

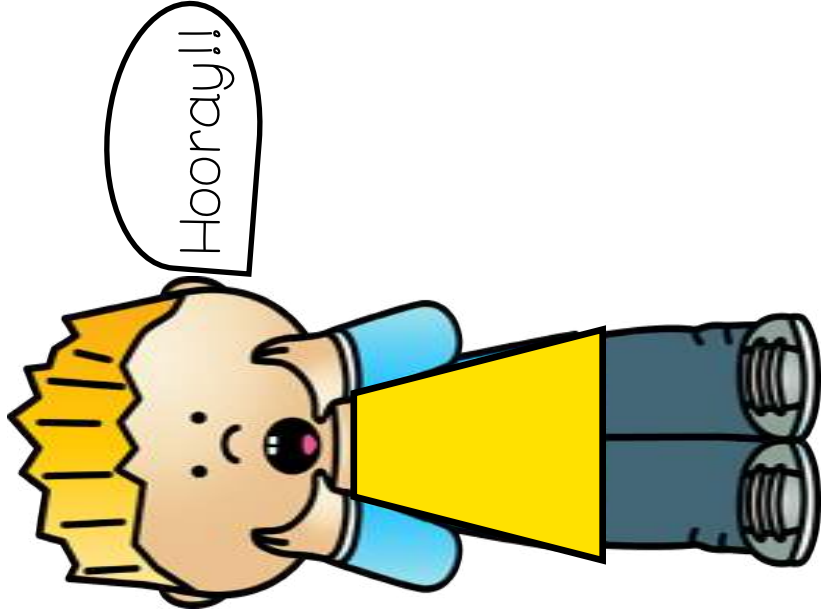

yellow shout hooray

What Color are you Wearing?

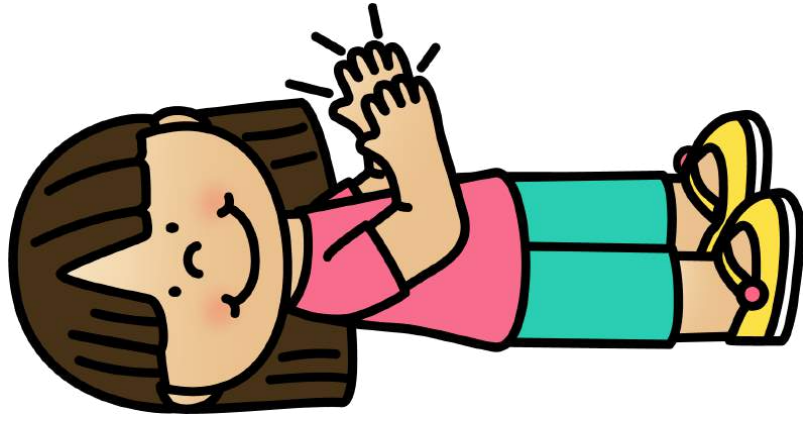

pink clap hands

What Color are you Wearing?

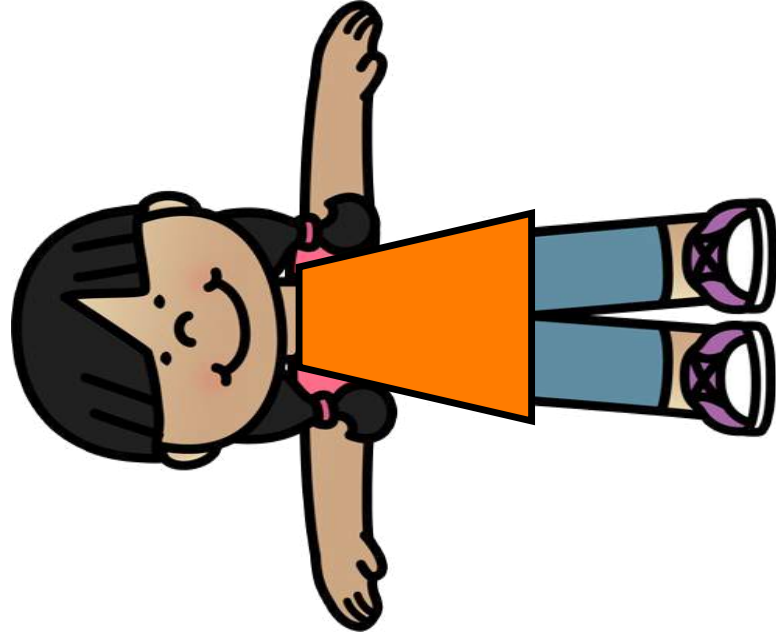

orange stretch arms

What Color are you Wearing?

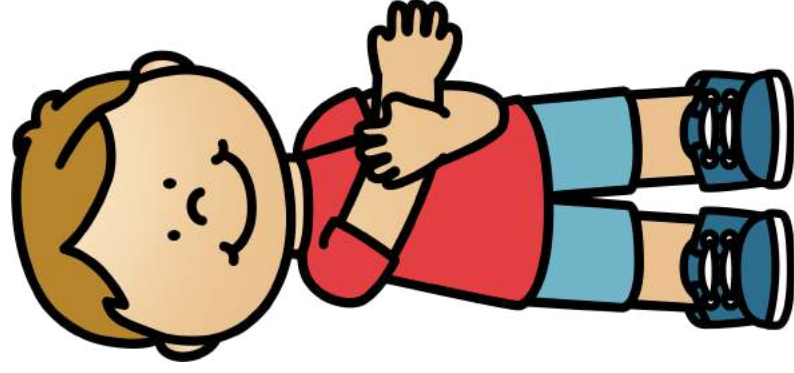

red stretch shoulders

What Color are you Wearing?

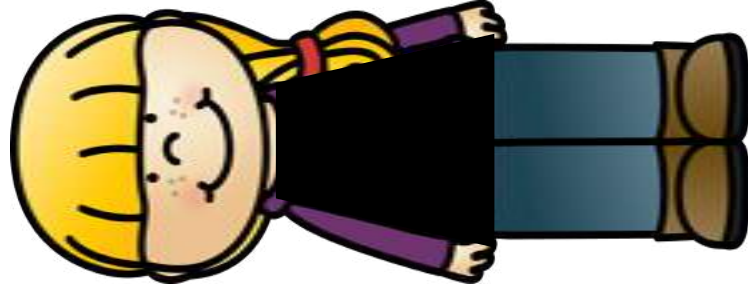

black pat hips

What Color are you Wearing?

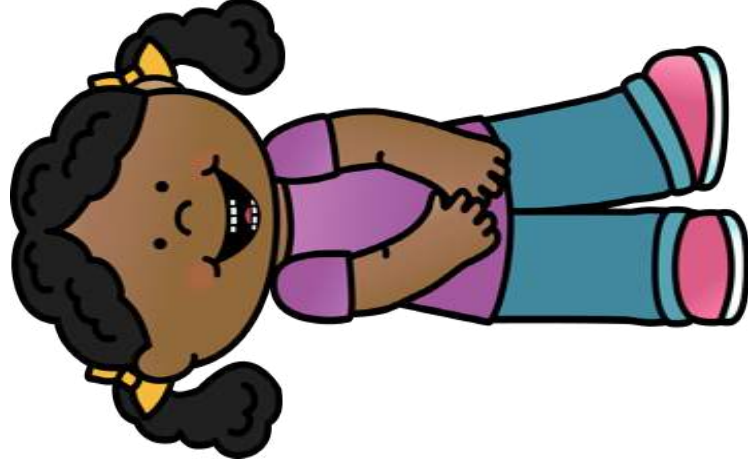

purple pat belly

Missing Crayons!

Missing crayons,
Where can they be?

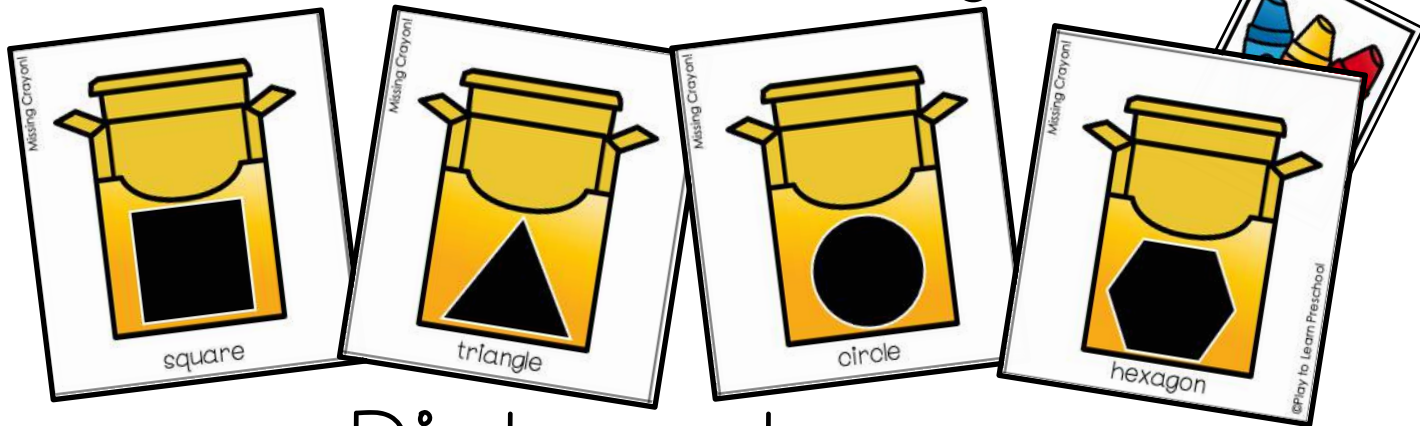

Pick a shape.
Let's look and see.

Missing Crayons!

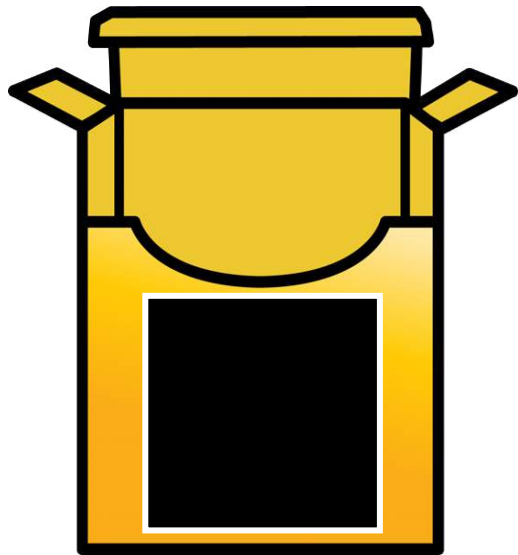

square

Missing Crayons!

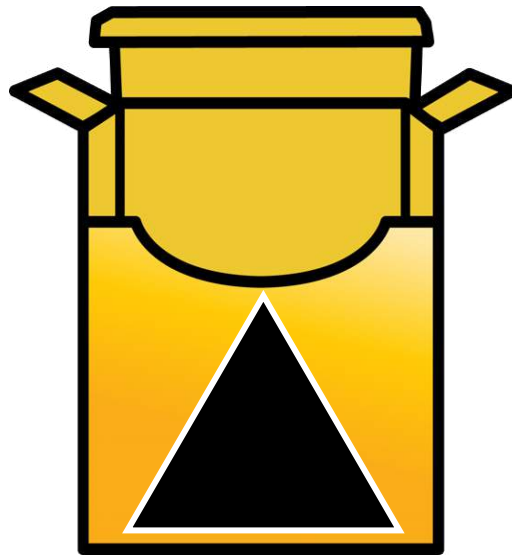

triangle

Missing Crayons!

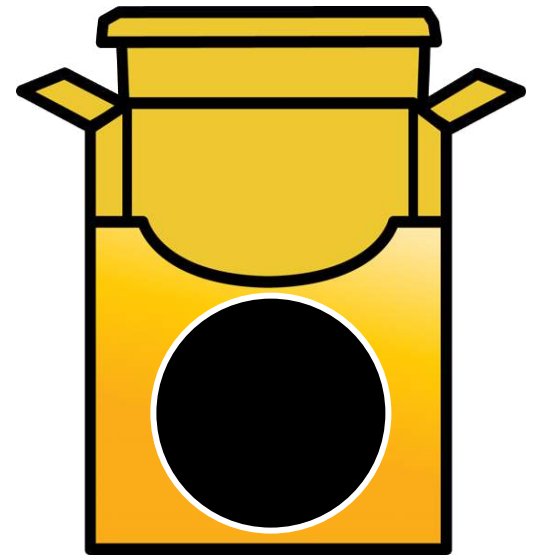

circle

Missing Crayons!

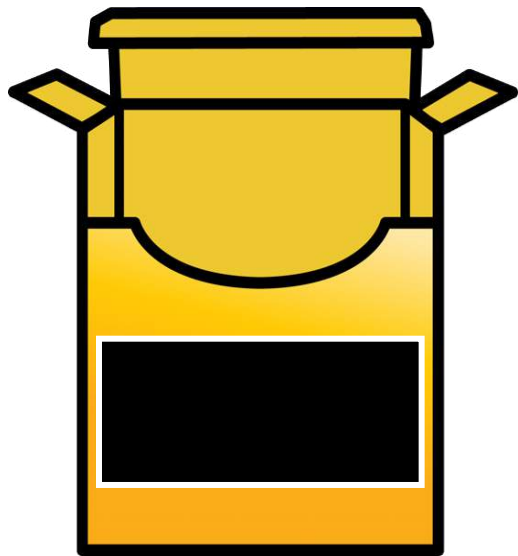

rectangle

Missing Crayons!

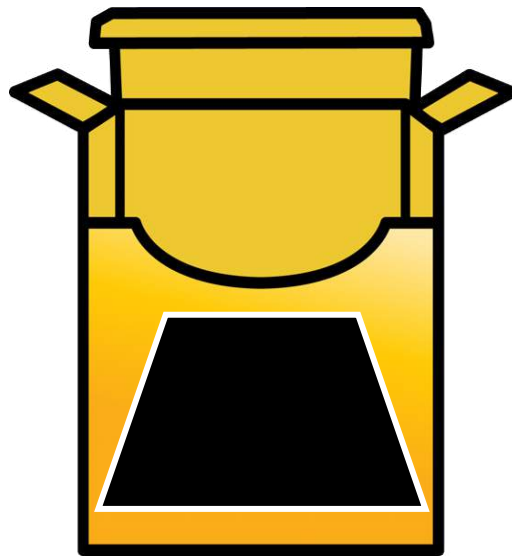

trapezoid

Missing Crayons!

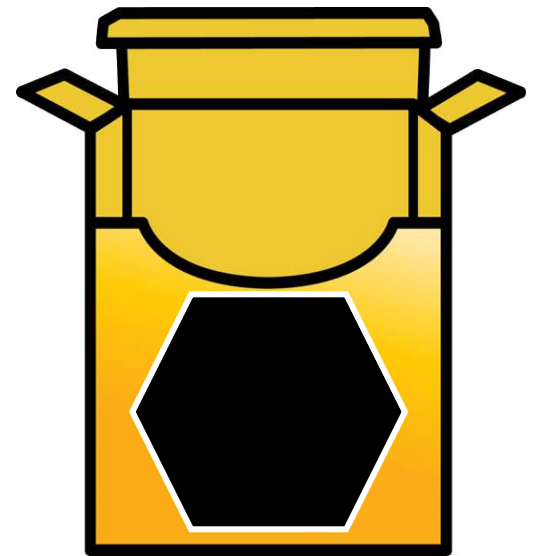

hexagon

Missing Crayons!

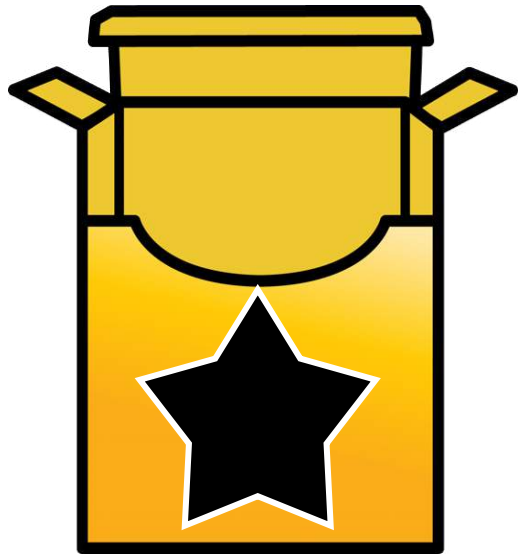

star

Missing Crayons!

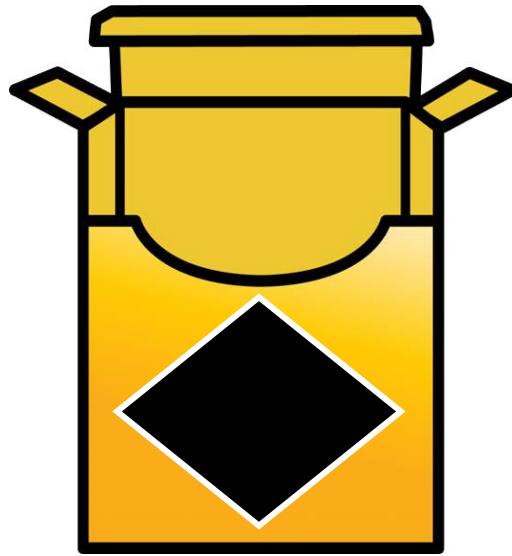

diamond

Missing Crayons!

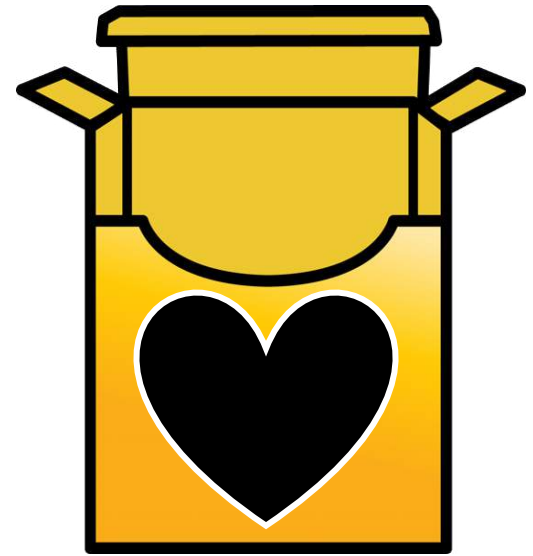

heart

Missing Crayons!

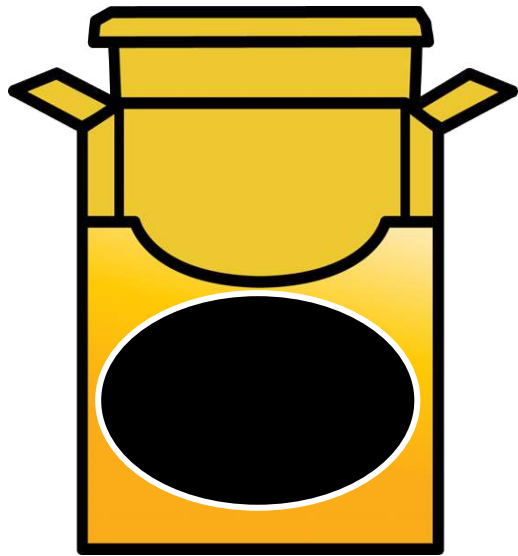

oval

Missing Crayons!

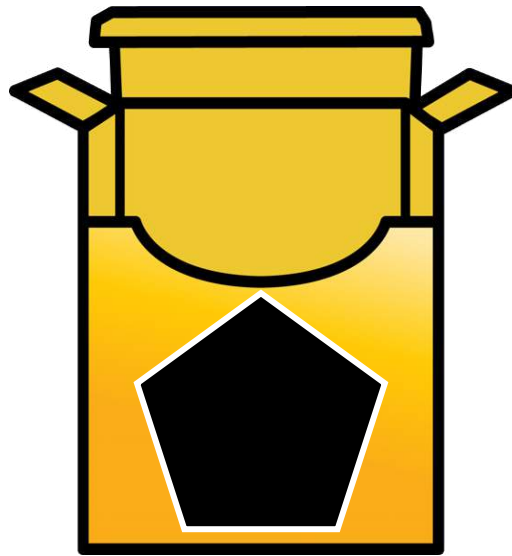

pentagon

Missing Crayons!

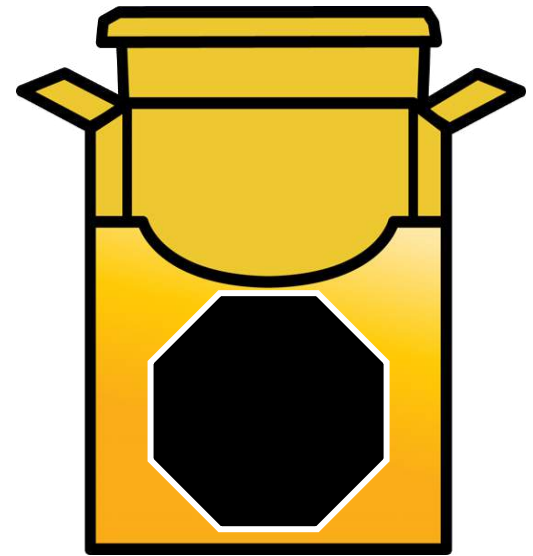

octagon

Missing Crayons!



crescent

Missing Crayons!

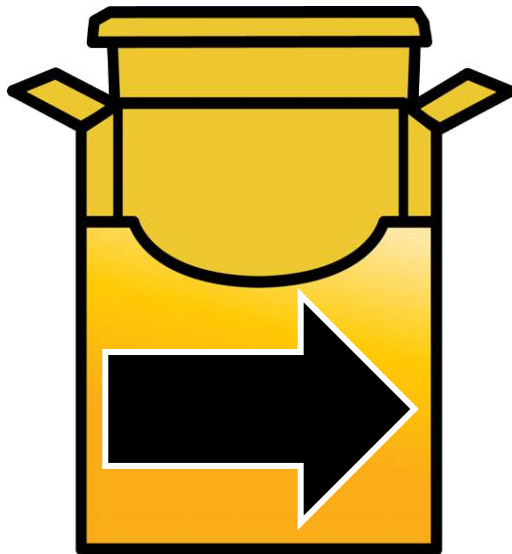

arrow

©Play to Learn Preschool

Cut out the crayons.

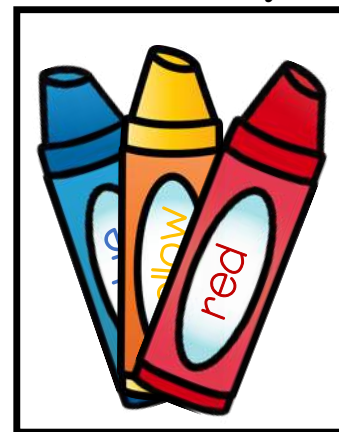

Monochromatic

Black and White

Day 4
lesson
plans

Monochromatic describes something that has one color. Black and white animals are a great way to show monochromatic color.

Objectives:

- The students will notice similarities and differences and ask questions.
- The students will demonstrate basic locomotor skills.
- The students will follow oral directions.

Activities:

1. Show the students the real pictures of black and white animals. Talk about the similarities and differences of the animals.
2. Print out the Black and White Animal Action die. Cut and assemble it. Have the students take turns rolling the die and then moving or sounding like the animals.
3. Play Black and White Bingo.

To Play the Game:

1. Students each receive 1 bingo card. Use counters or plastic chips as bingo markers.
2. Using the picture cards, pull a card and display on pocket chart in front of room.
3. Students mark the item on their card if applicable. Three in a horizontal row wins.

Extension Idea: Make beautiful, sparkly paint and create some monochromatic art.

<https://playtolearnpreschool.us/sparkly-snow-paint/>





Zebras use their black and white stripes to blend in with each other.



Dalmatians are white dogs with black spots.

Black and White Animal Actions!



Flap your arms
like a bat.



Trot like a zebra.



Shake your tail like
a skunk.



Meow like a cat.



Waddle like a penguin.



Bark like a dog.

- Copy this template on to cardstock, cut it out and fold it into a die.
- Children take turns rolling the die.
- Everyone makes the sound or action of the animal rolled.

Black and White Bingo



skunk

Black and White Bingo

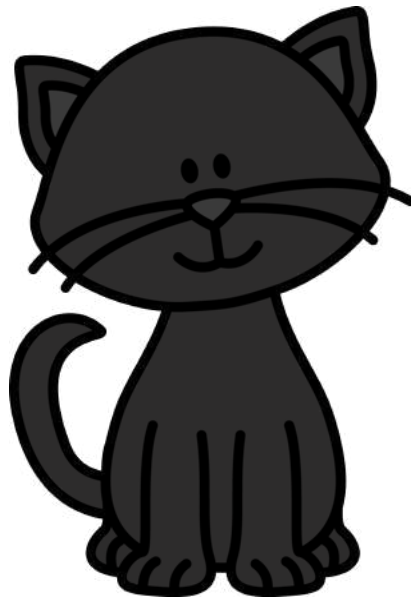

cat

Black and White Bingo



bats

Black and White Bingo

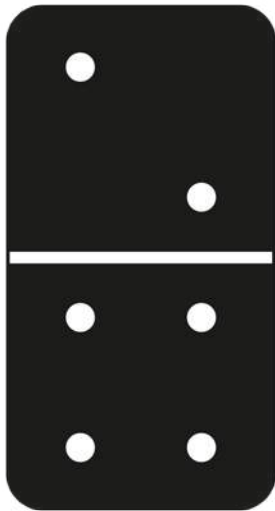

domino

Black and White Bingo



phone

Black and White Bingo

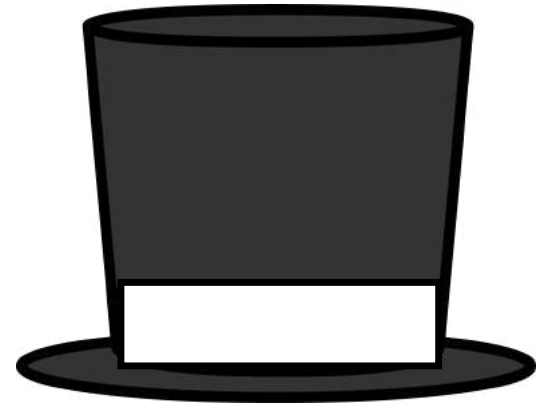

hat

Black and White Bingo

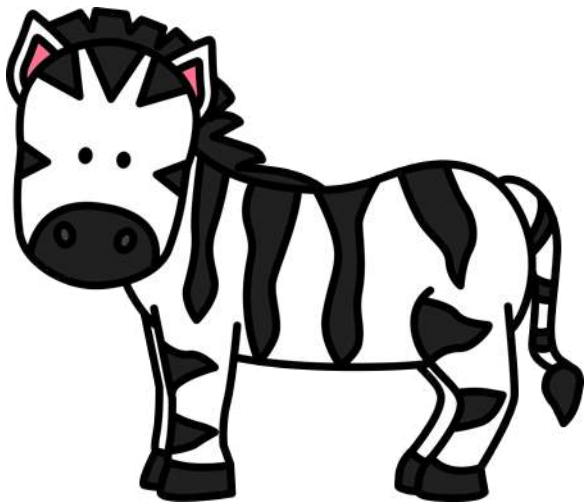

zebra

Black and White Bingo



dalmatian

Black and White Bingo



panda

Black and White Bingo

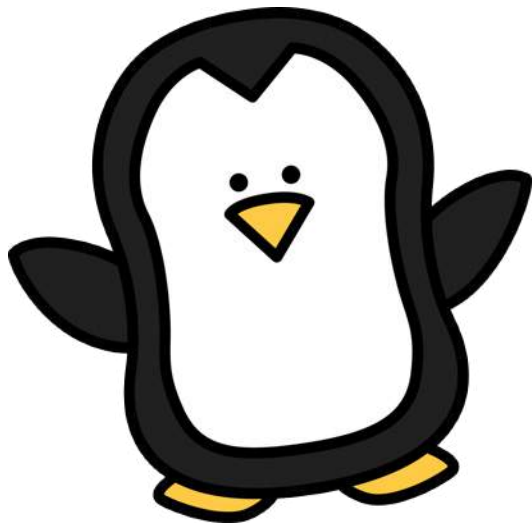

penguin

Black and White Bingo



police car

Black and White Bingo



newspaper

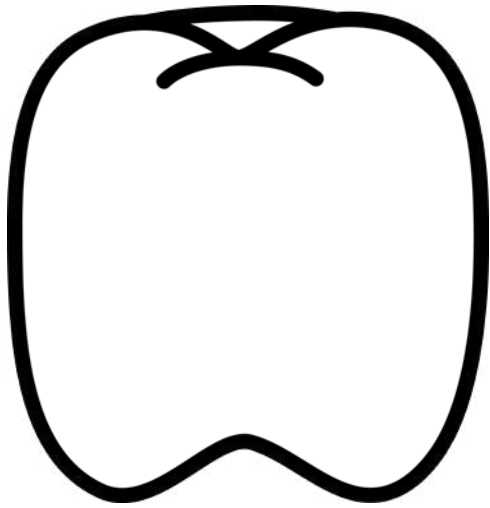

tooth

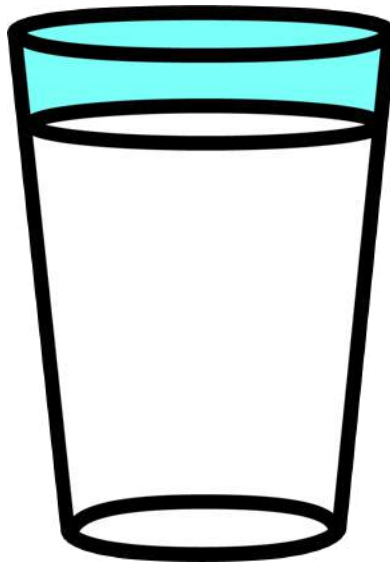

milk

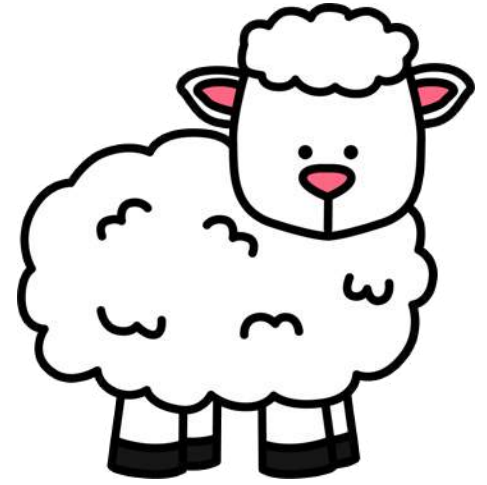

sheep

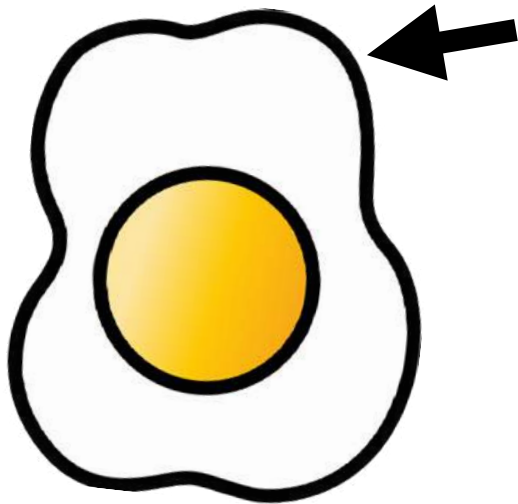

egg white

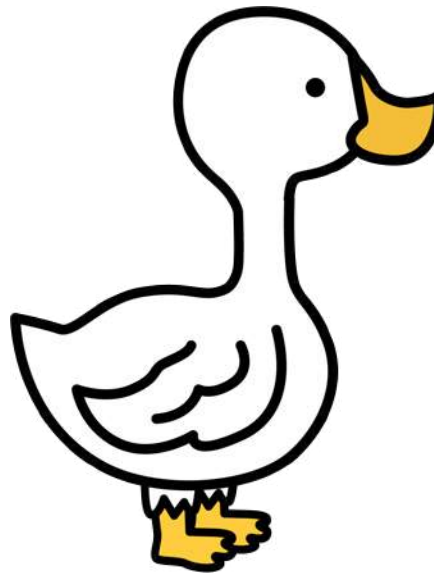

goose

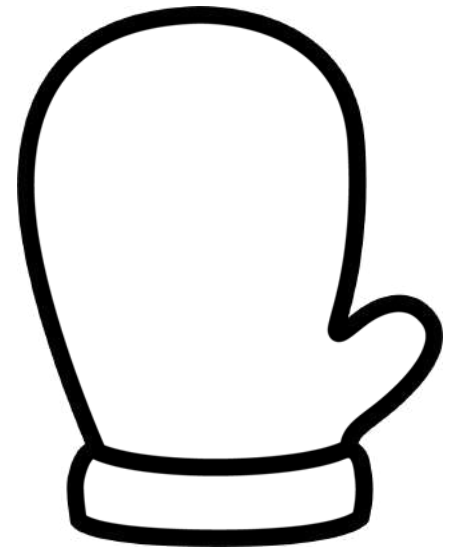



mitten

BINGO

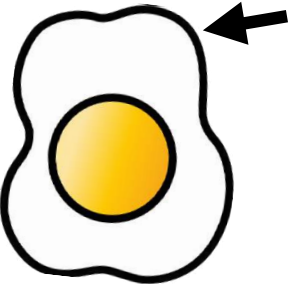
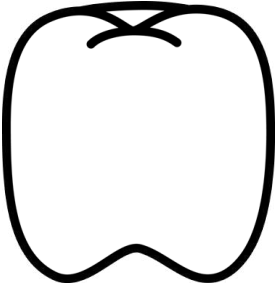
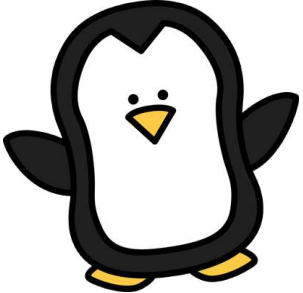

©Play to Learn Preschool

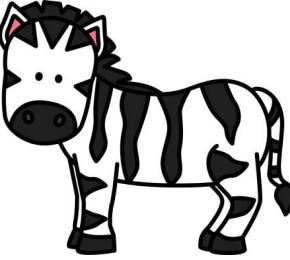
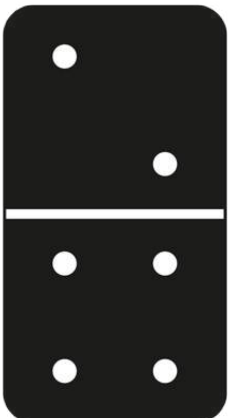

		
egg white	tooth	penguin

		
zebra	domino	skunk

BINGO

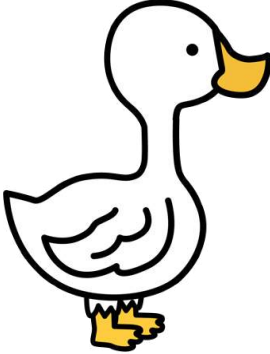
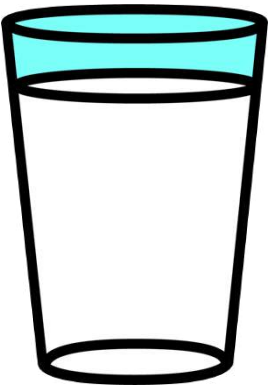

©Play to Learn Preschool

		
goose	milk	police car

		
dalmatian	phone	cat

BINGO



©Play to Learn Preschool

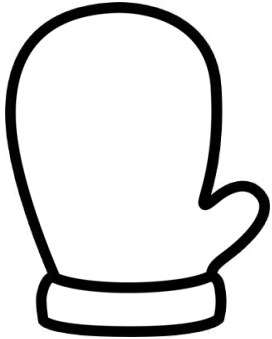

mitten

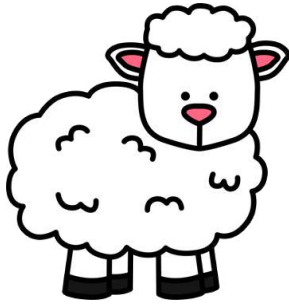

sheep



newspaper



panda

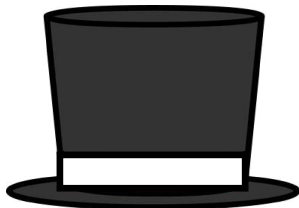

hat



bats

BINGO



©Play to Learn Preschool



bats

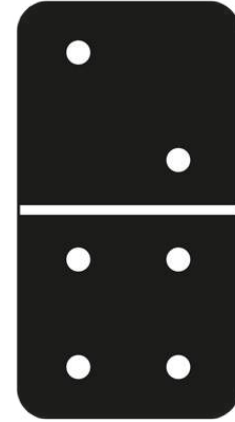

domino



panda

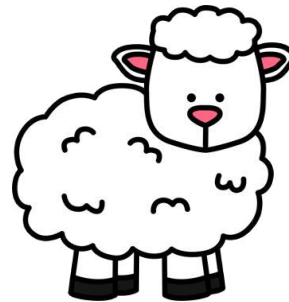

sheep

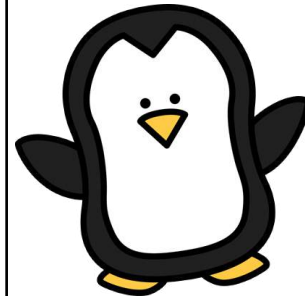

penguin

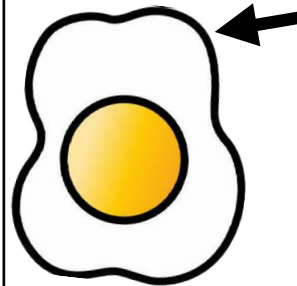





egg white

BINGO

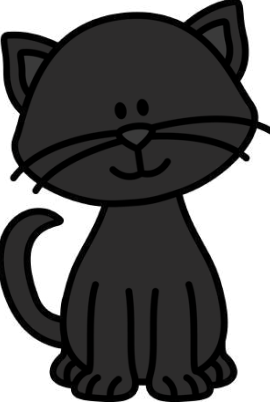

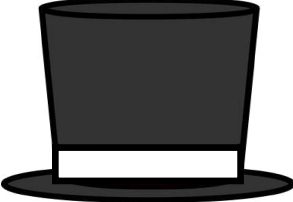
©Play to Learn Preschool

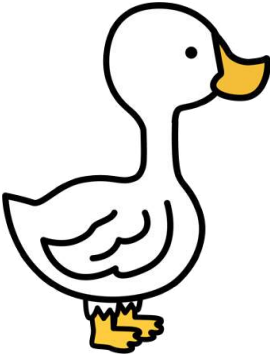
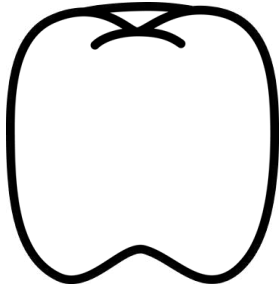

		
cat	skunk	hat

		
goose	tooth	newspaper

BINGO

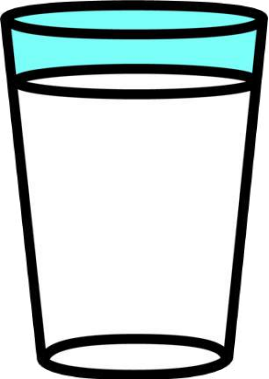

©Play to Learn Preschool

		
phone	milk	police car

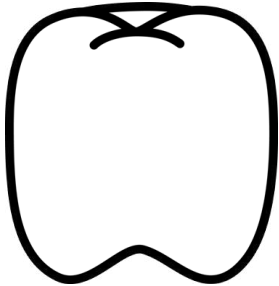
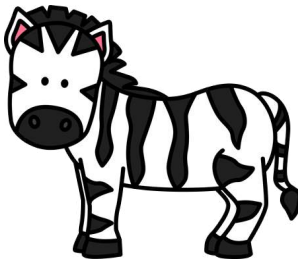
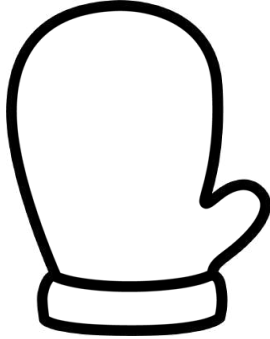
		
tooth	zebra	mitten

BINGO

©Play to Learn Preschool

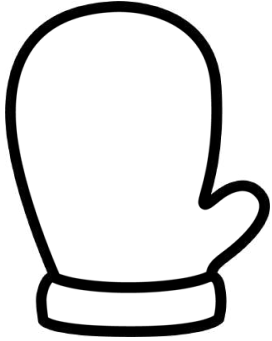

mitten

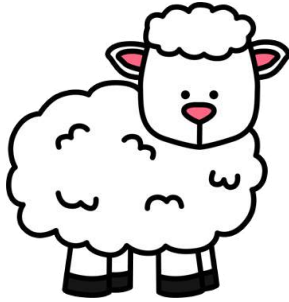

sheep

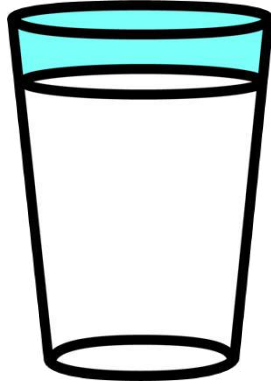

milk



panda

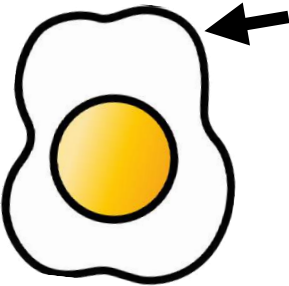

egg white



newspaper

BINGO

©Play to Learn Preschool

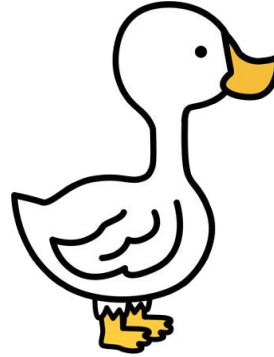

goose



phone



panda

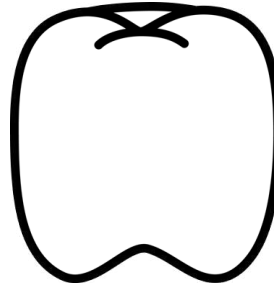

tooth





zebra



bats

BINGO

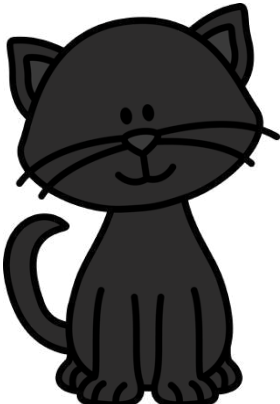
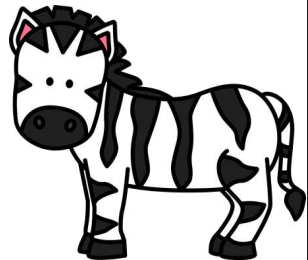
©Play to Learn Preschool

		
cat	zebra	newspaper

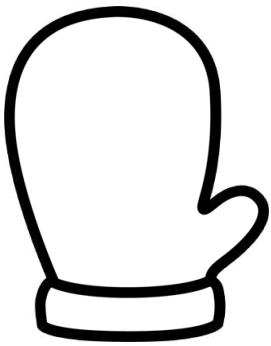
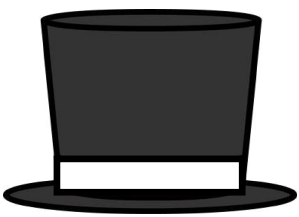
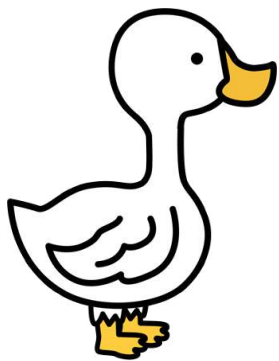
		
mitten	hat	goose

BINGO

©Play to Learn Preschool

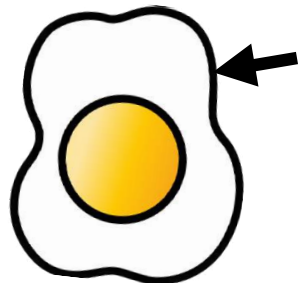
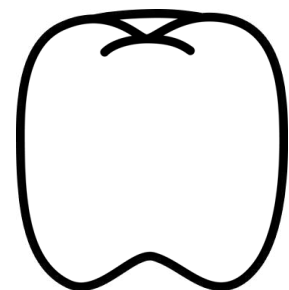
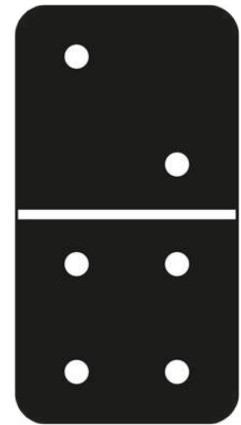
		
egg white	tooth	domino

		
police car	panda	milk

Rainbow

Red, Orange, Yellow, Green, Blue, Purple

A rainbow happens when sun shines through tiny droplets of water in the sky and the light is bent (refracted) to create the different colors.

Objectives:

- The students will notice similarities and differences and ask questions.
- The children will play with words, sounds, and rhymes.
- The children will demonstrate an understanding of print concepts.



Activities:

1. Show the real picture of the rainbow and ask if anyone has ever seen one. What colors do you see in the rainbow?
2. Sing the Rainbow Song to the tune of "Twinkle, Twinkle."
3. Label the different parts of the rainbow. Copy off the black and white template and have students color it in and trace the words.

Rainbow Song

To the tune of "Twinkle, Twinkle Little Star"

Red, orange, yellow, green and blue.
Don't forget there's purple too!
Put these colors in a row.
That's how to make
a big rainbow.
Red, orange, yellow,
Green and blue.
Don't forget
there's
purple too!



Extension Idea: Teach how to sign rainbow in ASL by moving one hand up in an arc, then down toward the other side of your body. It looks like your fingers are the arcs of the rainbow.

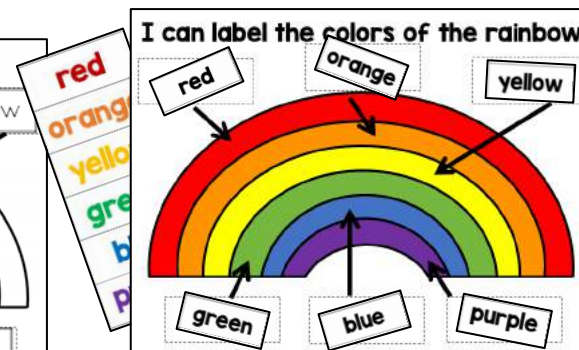
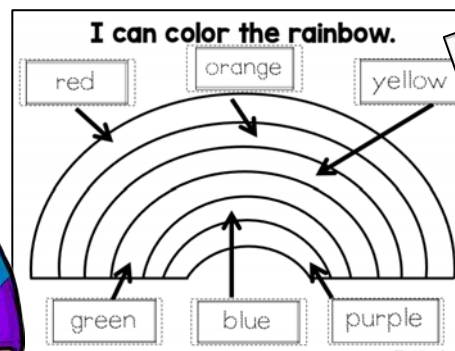



A rainbow is a sign of good luck. What do you think a double rainbow means?

Rainbow Song

To the tune of "Twinkle, Twinkle Little Star"

Red, orange, yellow, green and blue.

Don't forget there's purple too!

Put these colors in a row.

That's how to make
a big rainbow.

Red, orange, yellow,

green and blue.

Don't forget

there's

purple too!



I can label the colors of the rainbow.

[Empty dashed box for labeling]

[Empty dashed box for labeling]

[Empty dashed box for labeling]

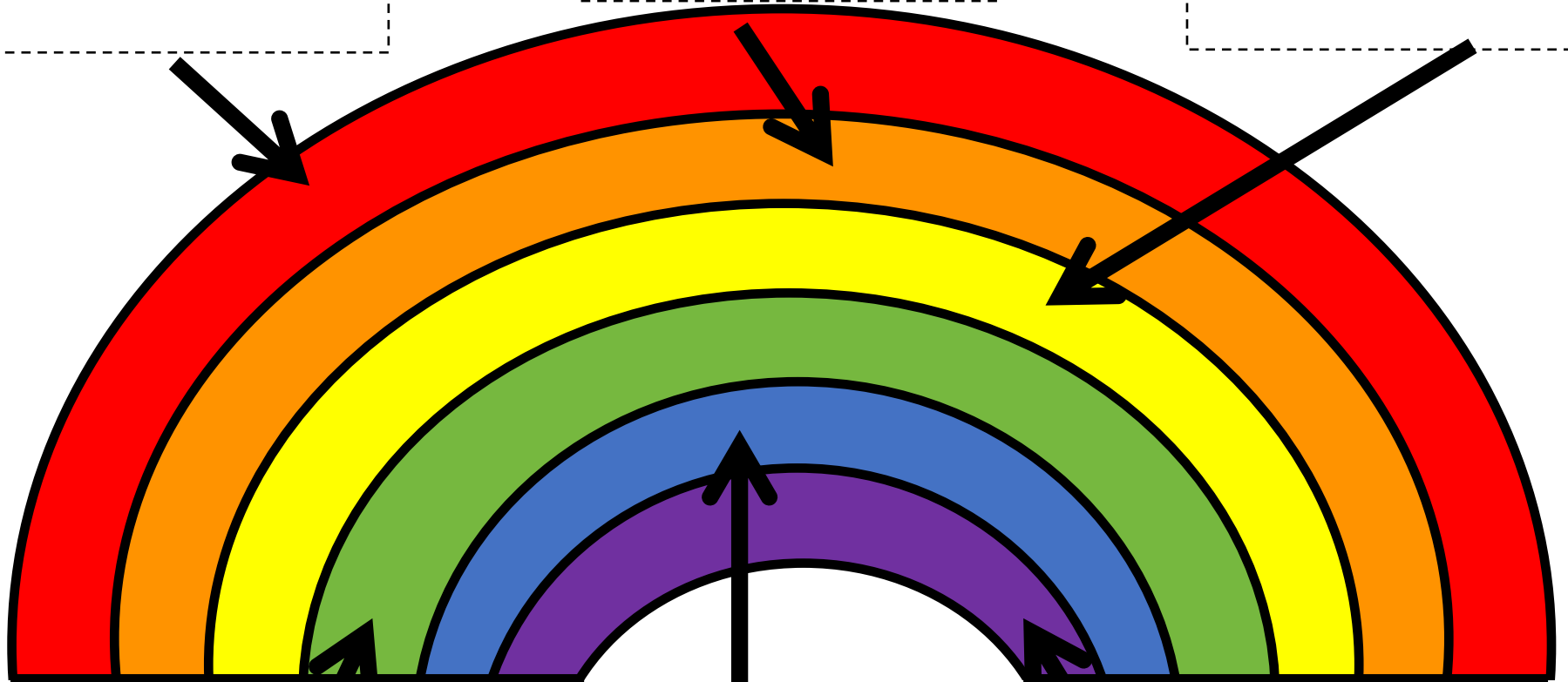

[Empty dashed box for labeling]

[Empty dashed box for labeling]

[Empty dashed box for labeling]

Use these cards to label the parts of a rainbow.

red

red

red

red

orange

orange

orange

orange

yellow

yellow

yellow

yellow

green

green

green

green

blue

blue

blue

blue

purple

purple

purple

purple

Use these cards to label the parts of a rainbow.

red

red

red

red

orange

orange

orange

orange

yellow

yellow

yellow

yellow

green

green

green

green

blue

blue

blue

blue

purple

purple

purple

purple

I can color the rainbow.

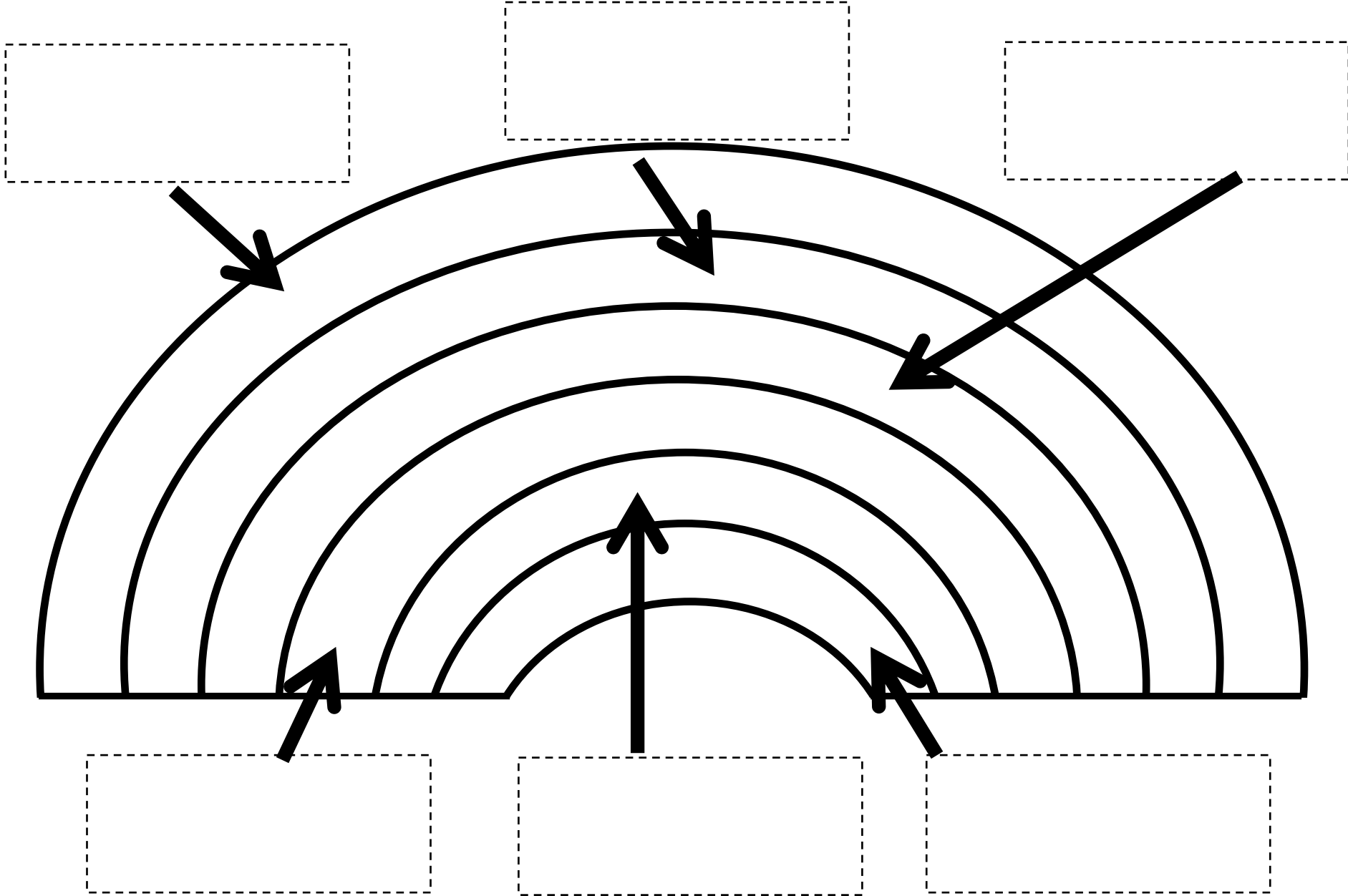

Use these cards to label the parts of a rainbow.

red

red

red

red

orange

orange

orange

orange

yellow

yellow

yellow

yellow

green

green

green

green

blue

blue

blue

blue

purple

purple

purple

purple

Mixing

Creating new colors

Day 6
lesson
plans

Mixing colors together can create new colors. It all starts with the primary colors red, yellow, and blue.

Objectives:

- The students will notice similarities and differences and ask questions.
- The students will share and take turn with others.
- The students will follow oral directions.

Activities:

1. Examine the real pictures with the students. Point out the red paint under the artist's hand and then the blue paint on the paintbrush. Talk about what color was made and what colors will be made.
2. Play the carpet game – Mouse in the House. Copy the colored houses or use the black and white template to copy on to your own colored construction paper. While the students cover their eyes, hide the mouse under 1 house. Then chant the poem and choose someone to guess what color house the mouse is under.
3. Sing “Mix It Together”. Fold the card pages in half. Show the two color side first, then the mixed color side as you sing.



Extension Idea: Check out the linked activity for fingerpainting project. Use the included color combination cards to make a booklet for the children to take home afterwards.

<https://playtolearnpreschool.us/paint-and-color-theory/>

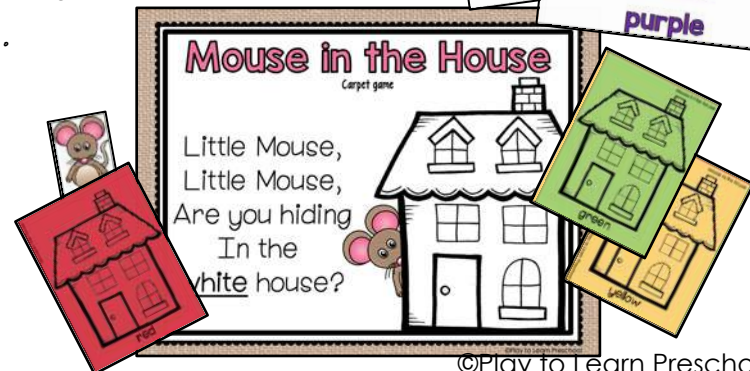
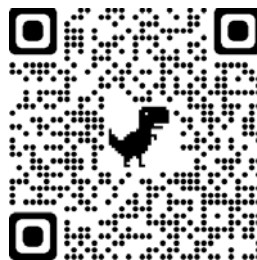



**This artist mixed red and blue
to make purple.**



**Mixing blue and yellow makes green.
What will red and yellow make?**

Mix It Together!

To the tune of "Three Blind Mice"

Blue and red. Blue and red.

What do they make?

What do they make?

Mix them together to get purple.

Mix them together to get purple.

Mix them together to get purple.

Blue and red!

**Repeat the verse and
replace the colors with:**

red and yellow = orange

yellow and blue = green



Mix It Together

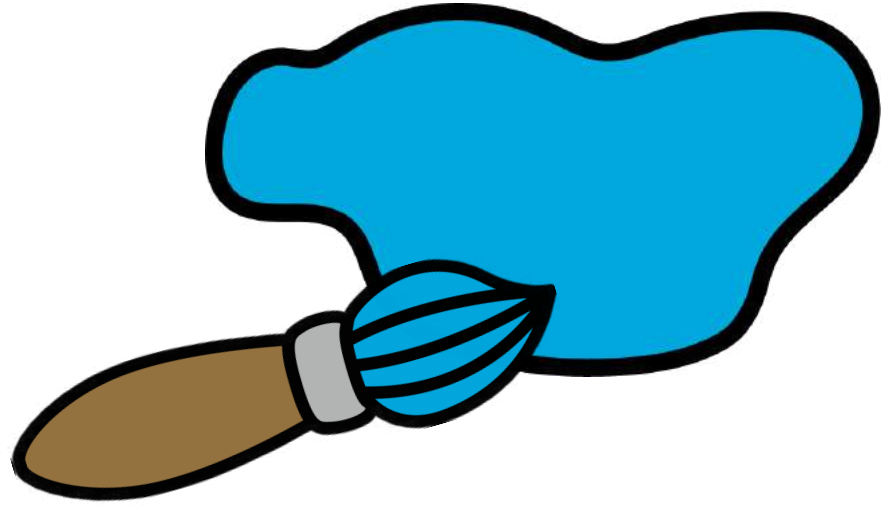

blue

Mix It Together

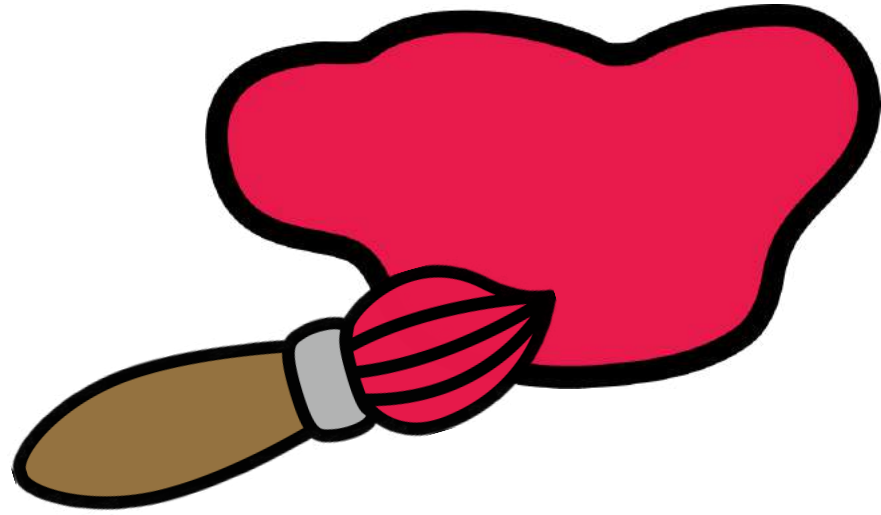

red

Mix It Together



purple

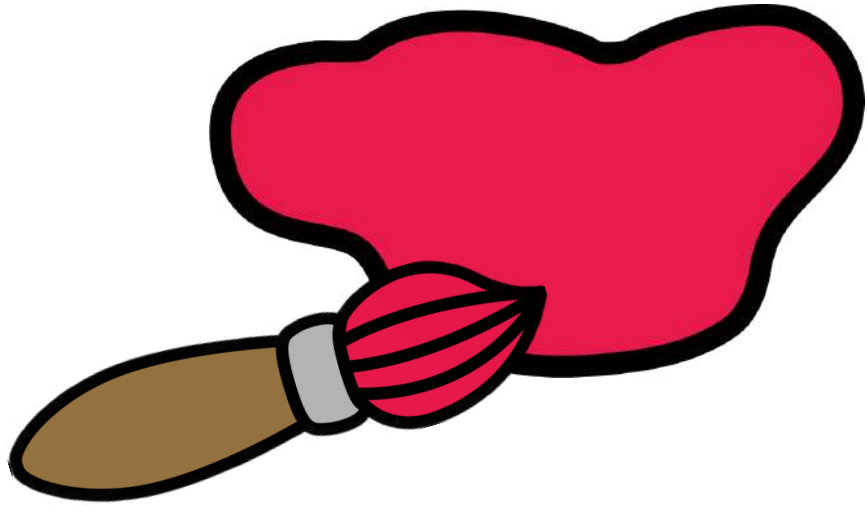

red

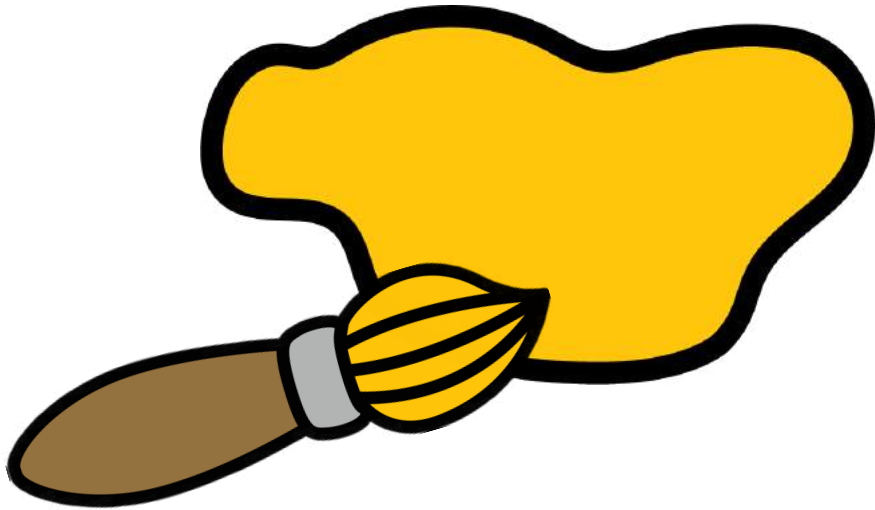

yellow



orange

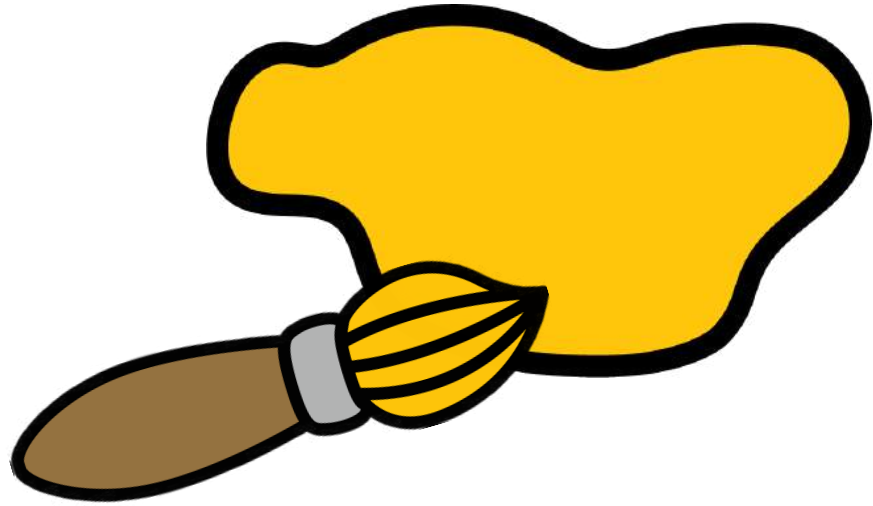

yellow

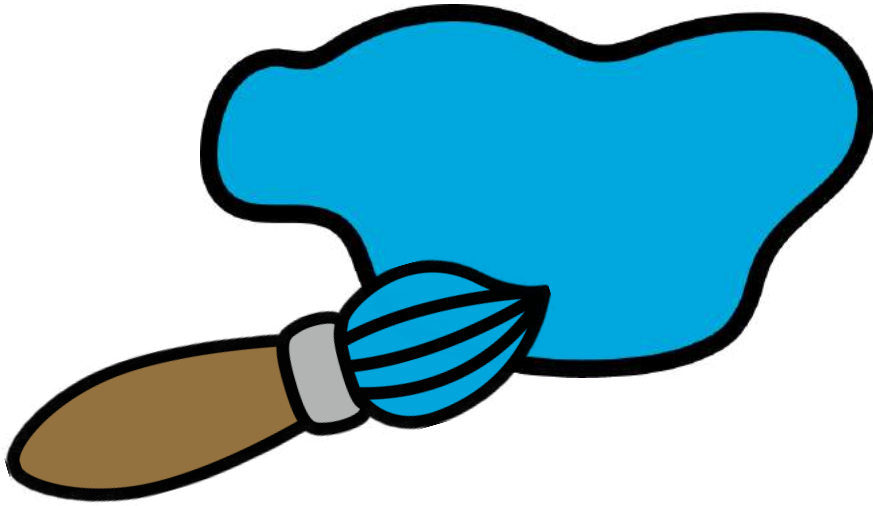

blue



green

Mix It Together



yellow

Mix It Together

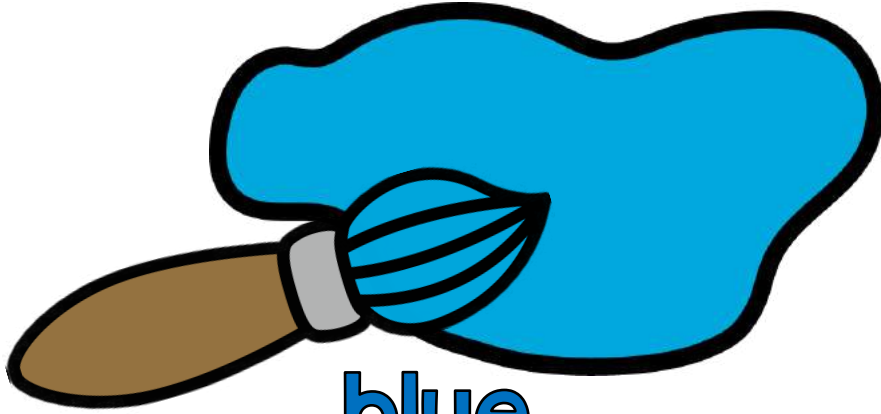

blue

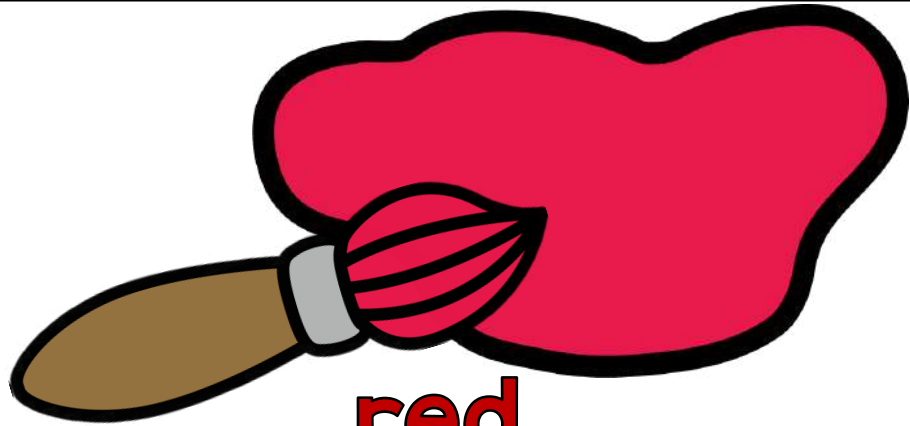

red

Mix It Together



brown

Mouse in the House

Carpet game

Little Mouse,
Little Mouse,
Are you hiding
In the
white house?

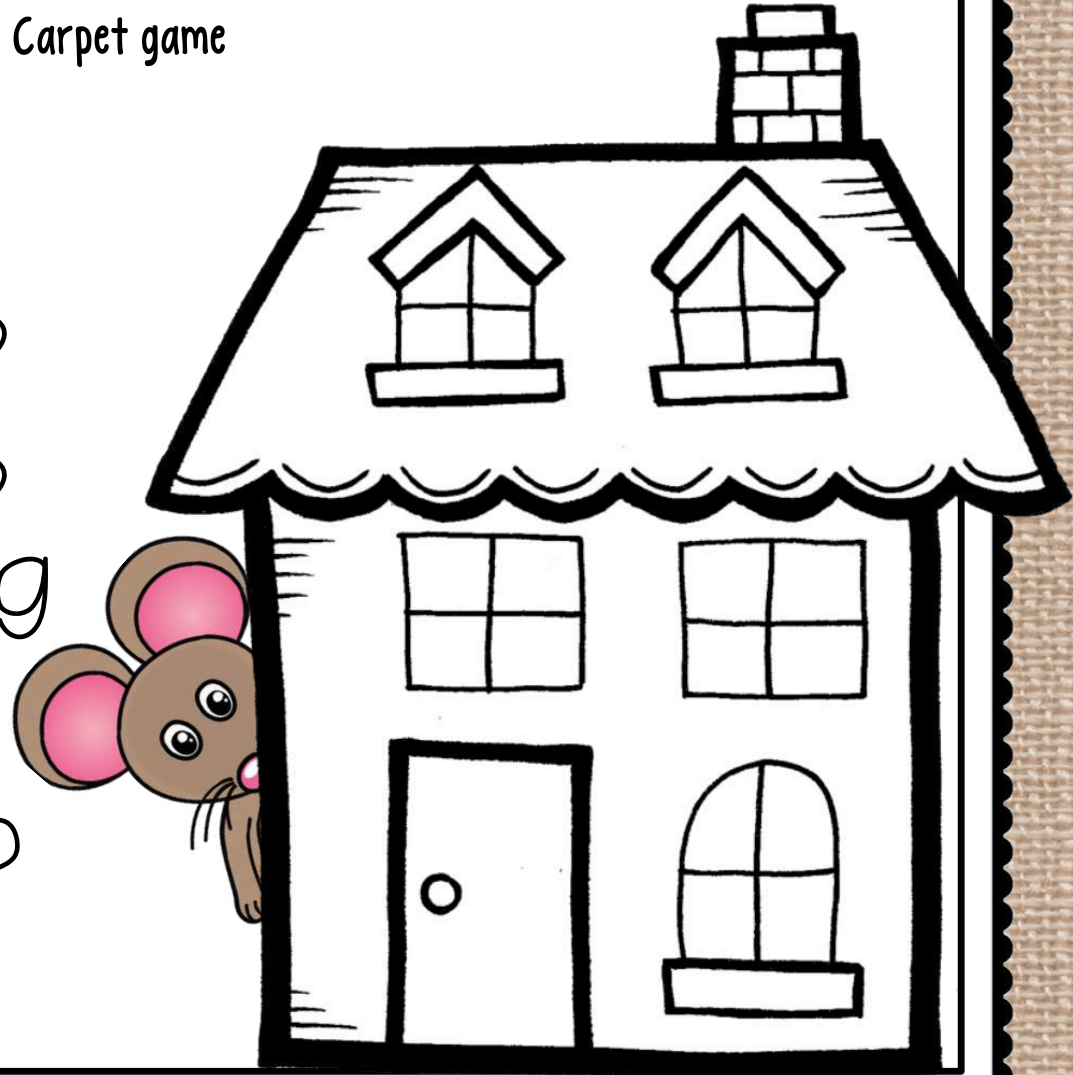

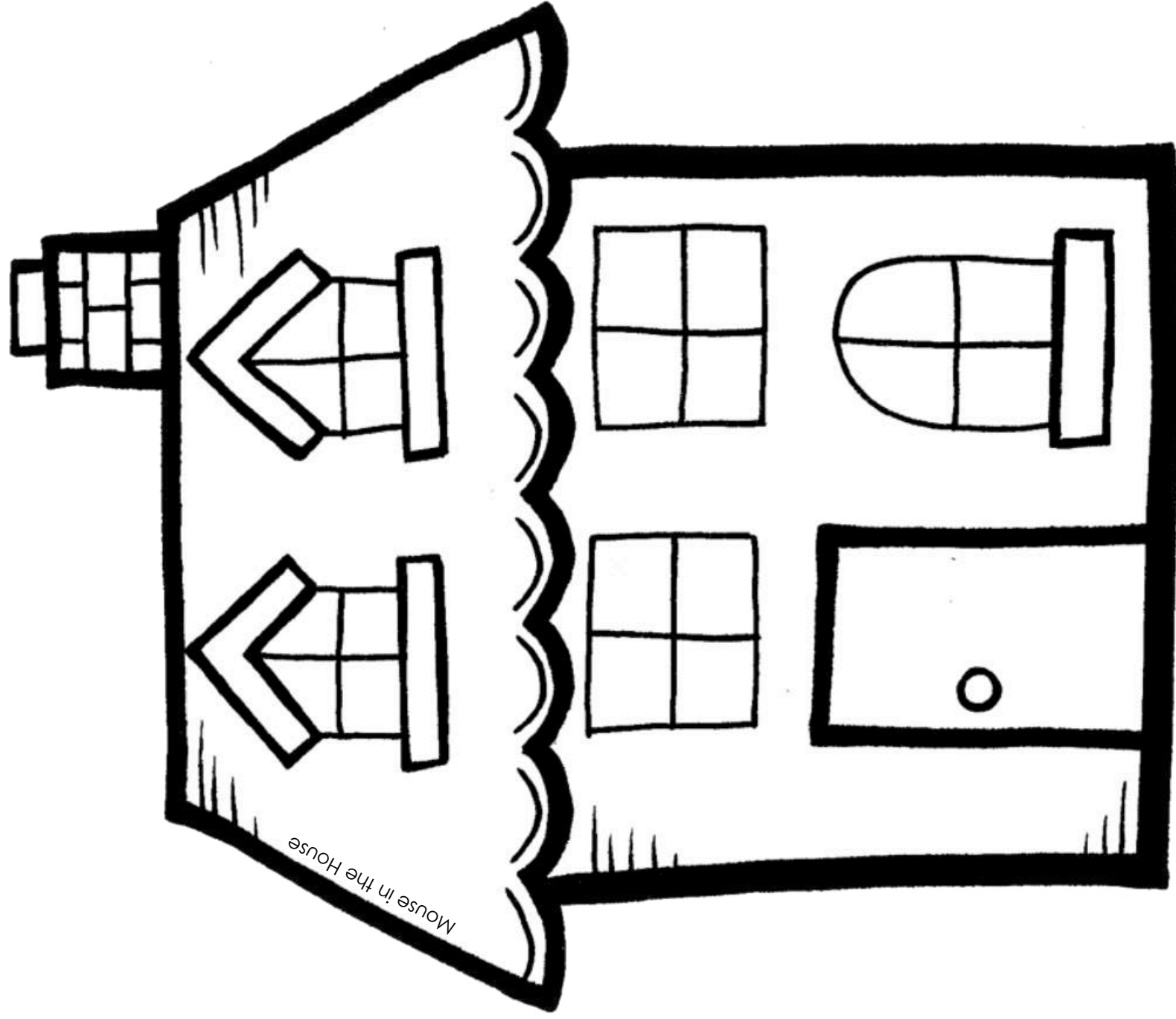

Mouse in the House

Where is the mouse?

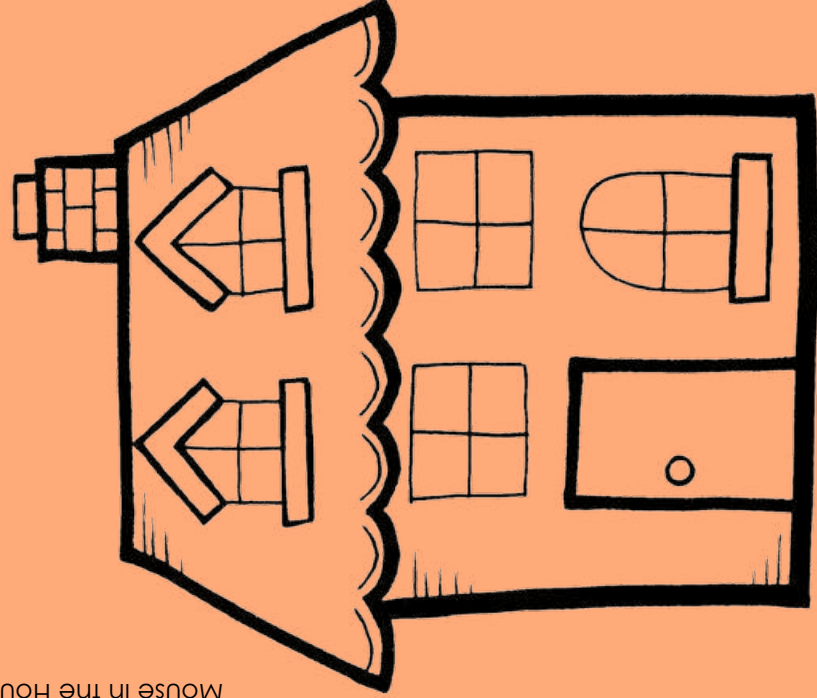

orange

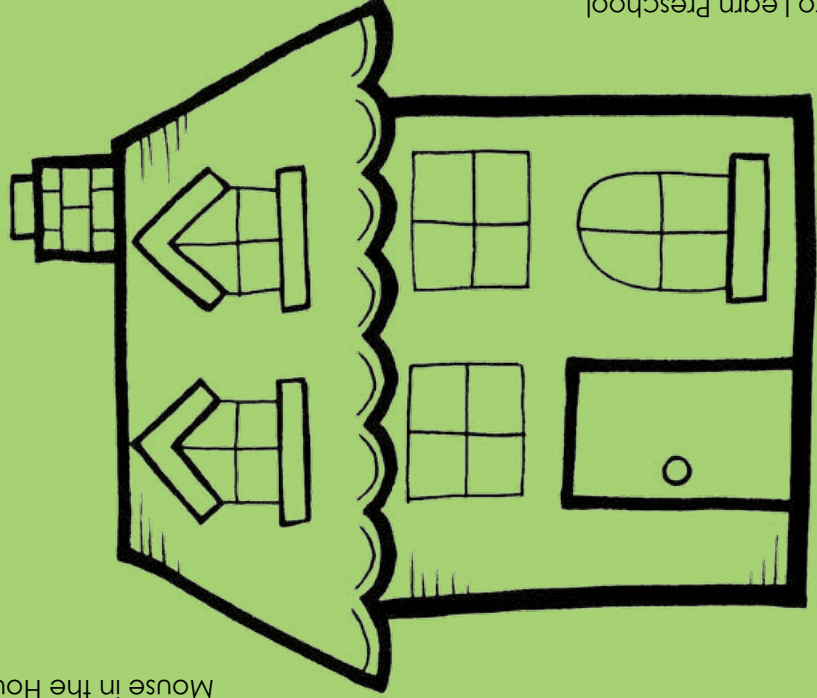

green

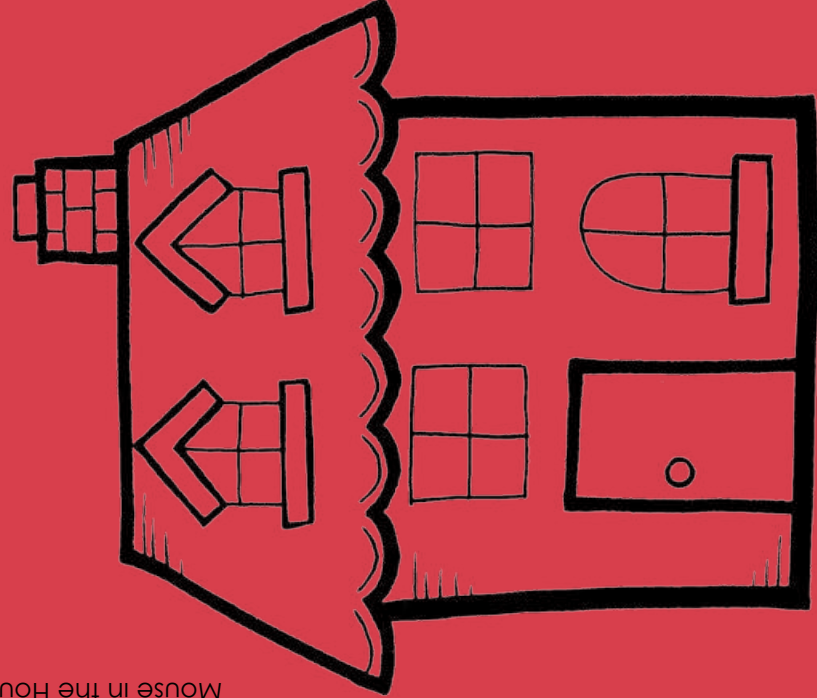

red

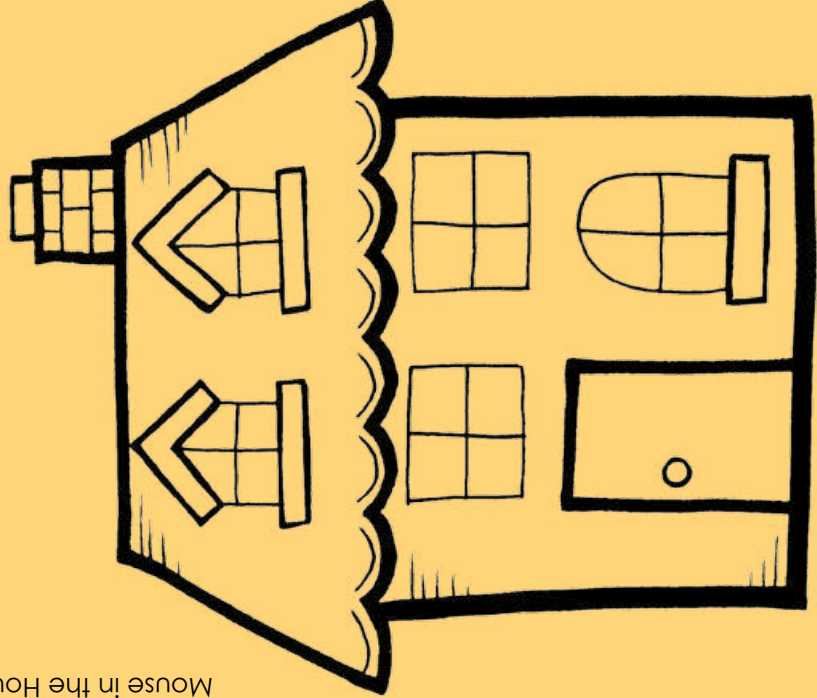

yellow

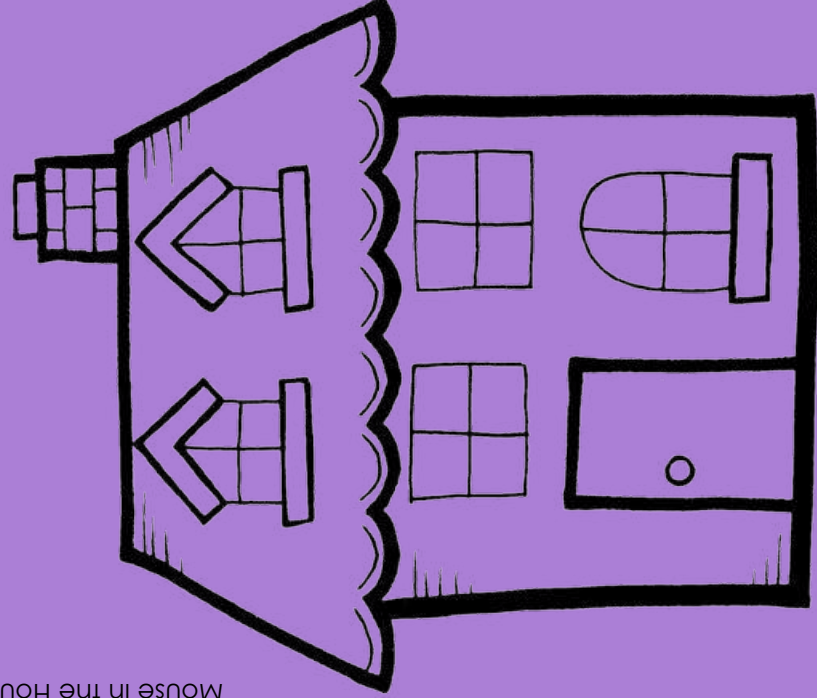

purple

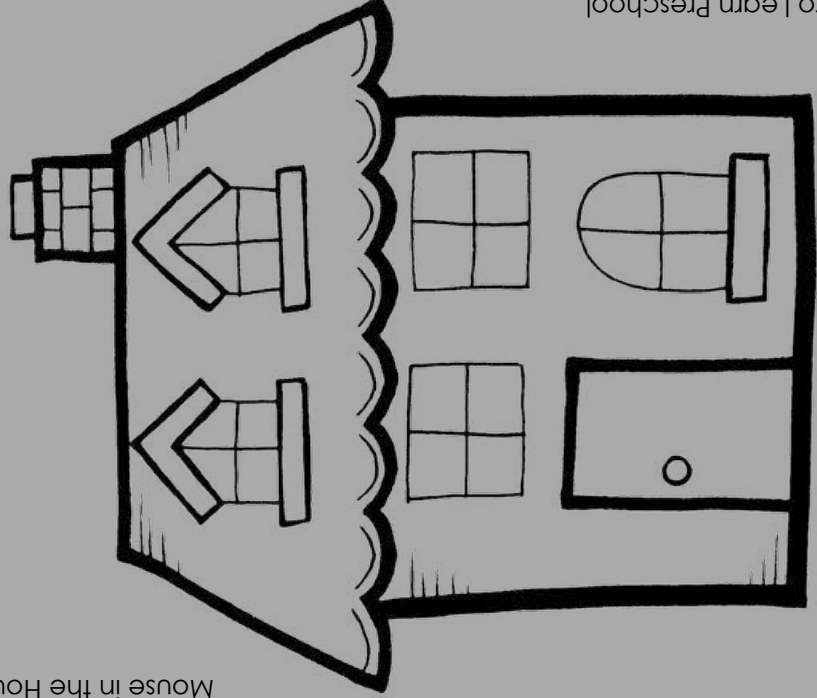

gray

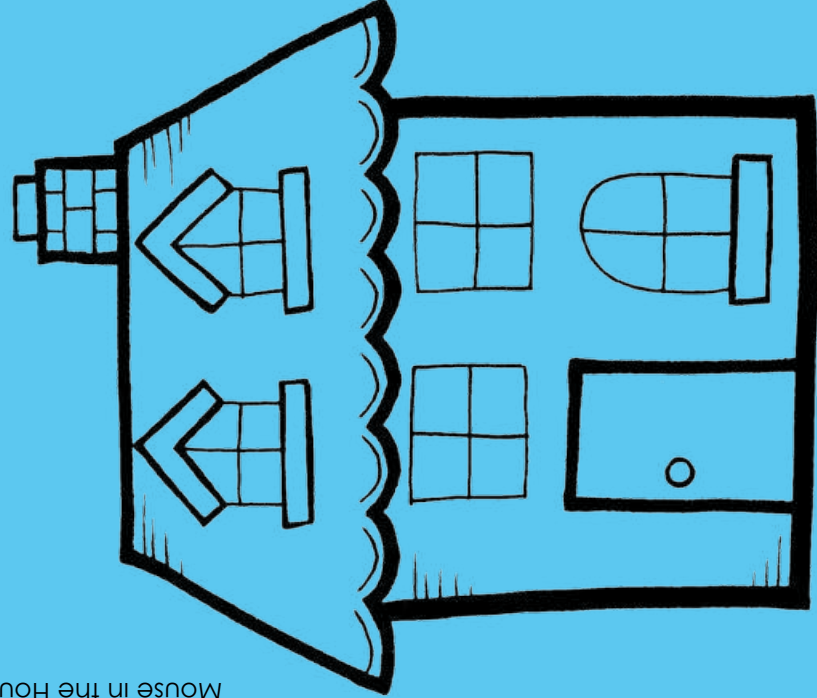

blue

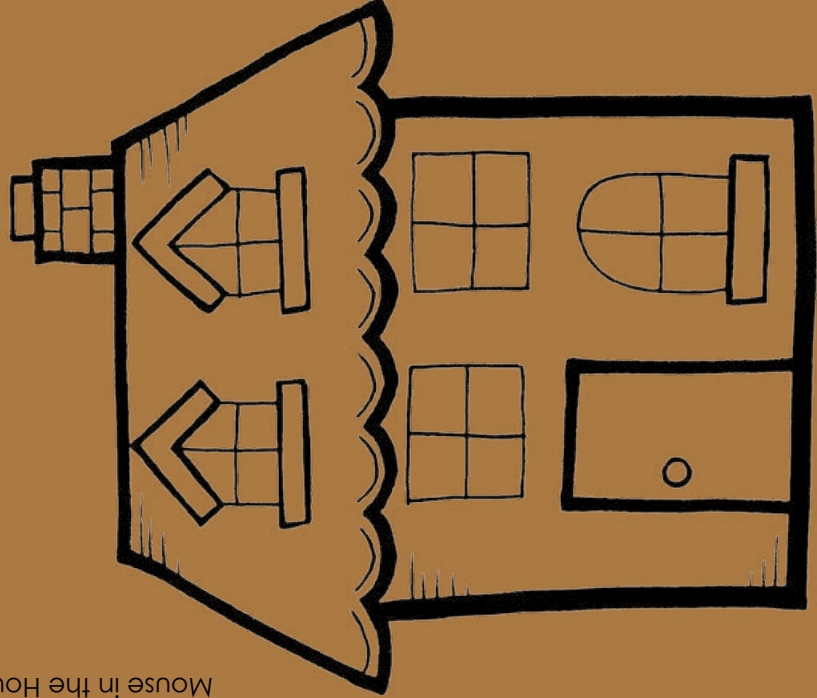

brown

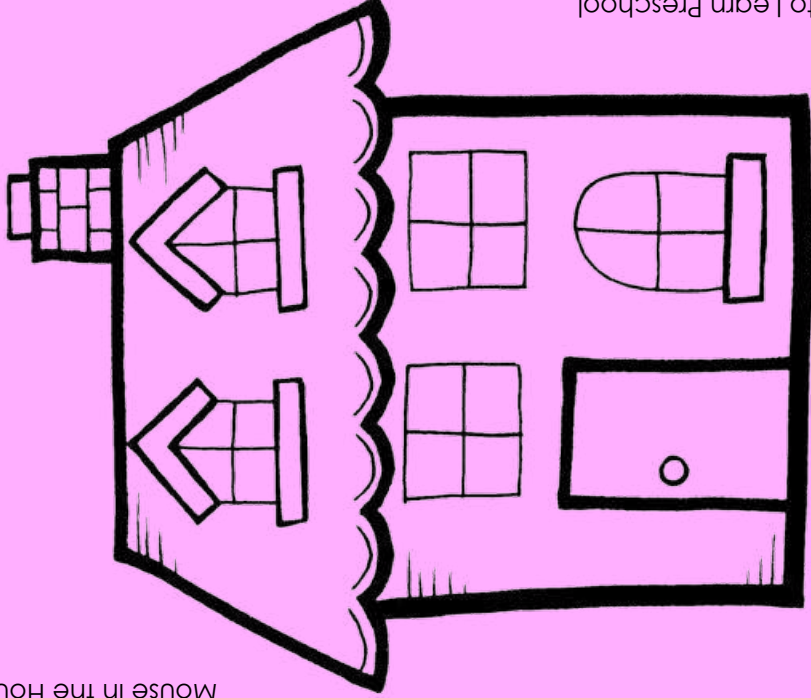

pink

Mouse in the House

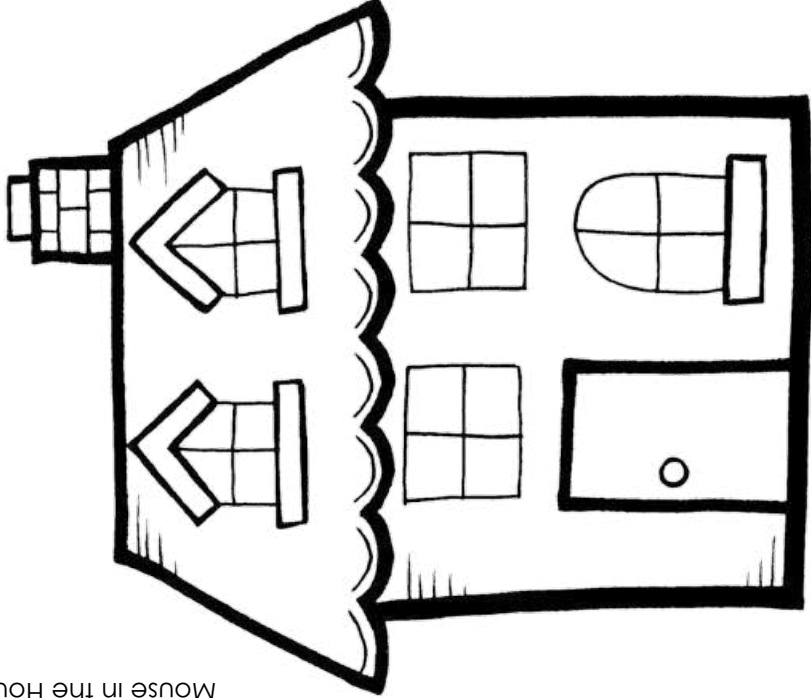

white

Mouse in the House

Cut out this mouse to hide under a house.

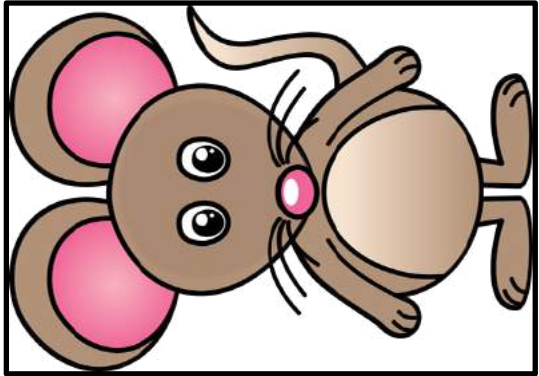

Mouse in the House

Ask me what
happened when I
mixed

red and blue!

Ask me what
happened when I
mixed

red and blue!

Ask me what
happened when I
mixed

red and blue!

Ask me what
happened when I
mixed

red and blue!

Ask me what
happened when I
mixed

red and blue!

Ask me what
happened when I
mixed

red and blue!

Ask me what
happened when I
mixed

red and blue!

Ask me what
happened when I
mixed

red and blue!

Ask me what
happened when I
mixed

red and blue!

Ask me what
happened when I
mixed

red and yellow!

Ask me what
happened when I
mixed

red and yellow!

Ask me what
happened when I
mixed

red and yellow!

Ask me what
happened when I
mixed

red and yellow!

Ask me what
happened when I
mixed

red and yellow!

Ask me what
happened when I
mixed

red and yellow!

Ask me what
happened when I
mixed

red and yellow!

Ask me what
happened when I
mixed

red and yellow!

Ask me what
happened when I
mixed

red and yellow!

Ask me what
happened when I
mixed

blue and yellow!

Ask me what
happened when I
mixed

blue and yellow!

Ask me what
happened when I
mixed

blue and yellow!

Ask me what
happened when I
mixed

blue and yellow!

Ask me what
happened when I
mixed

blue and yellow!

Ask me what
happened when I
mixed

blue and yellow!

Ask me what
happened when I
mixed

blue and yellow!

Ask me what
happened when I
mixed

blue and yellow!

Ask me what
happened when I
mixed

blue and yellow!

Ask me what
happened when I
mixed

**red, blue,
and yellow!**

Ask me what
happened when I
mixed

**red, blue,
and yellow!**

Ask me what
happened when I
mixed

**red, blue,
and yellow!**

Ask me what
happened when I
mixed

**red, blue,
and yellow!**

Ask me what
happened when I
mixed

**red, blue,
and yellow!**

Ask me what
happened when I
mixed

**red, blue,
and yellow!**

Ask me what
happened when I
mixed

**red, blue,
and yellow!**

Ask me what
happened when I
mixed

**red, blue,
and yellow!**

Ask me what
happened when I
mixed

**red, blue,
and yellow!**

Best Play Dough Recipe

1 cup flour
1 Tbsp. cream of tartar
 $\frac{1}{2}$ cup salt
1 cup water
2 Tbsp. oil
food coloring



Mix all ingredients together. Cook over medium heat, stirring constantly. When the dough forms and pulls away from the sides of the pan, remove from heat. let the dough cool. Knead the dough until it's smooth! Store in an airtight container.

Shade

Lighter and Darker

Day 7
lesson
plans

Different shades of a color can be made by adding white or black. Gray can be made by adding a little black to white. Tan can be made by adding a little brown to white.

Objectives:

- The students will notice similarities and differences and ask questions.
- Students will play with words, sounds, and rhymes.
- The students will notice and extend simple patterns.

Activities:

1. Examine the photo posters with shade. Talk about how the colors get lighter when white is added.
2. Start a fun shade chant with the students. Fold the paint pages in half and have them guess what the new color will be.
3. Grid Game – Items that can be different colors.

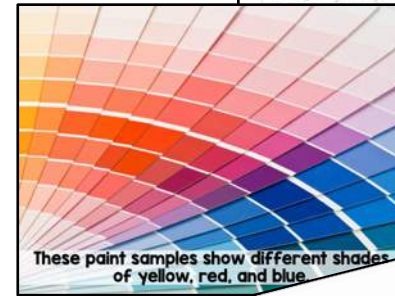

To Play:

1. Copy template page onto 5 different colors of paper.
2. Create a grid where each column has the same item, and each row is the same color. Discuss the pattern and relationship of the cards.
3. Students close their eyes while the teacher removes 1 card.
4. Students use their knowledge of patterns to determine which card (color and picture) is missing.

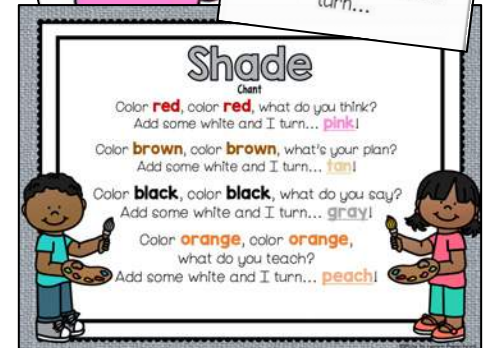

Extension Idea:

Choose 1 color of paint. Mix that color with white to make it lighter. Mix it with black to make it darker. Fold a piece of paper into 3rds and paint the 3 shades of color.

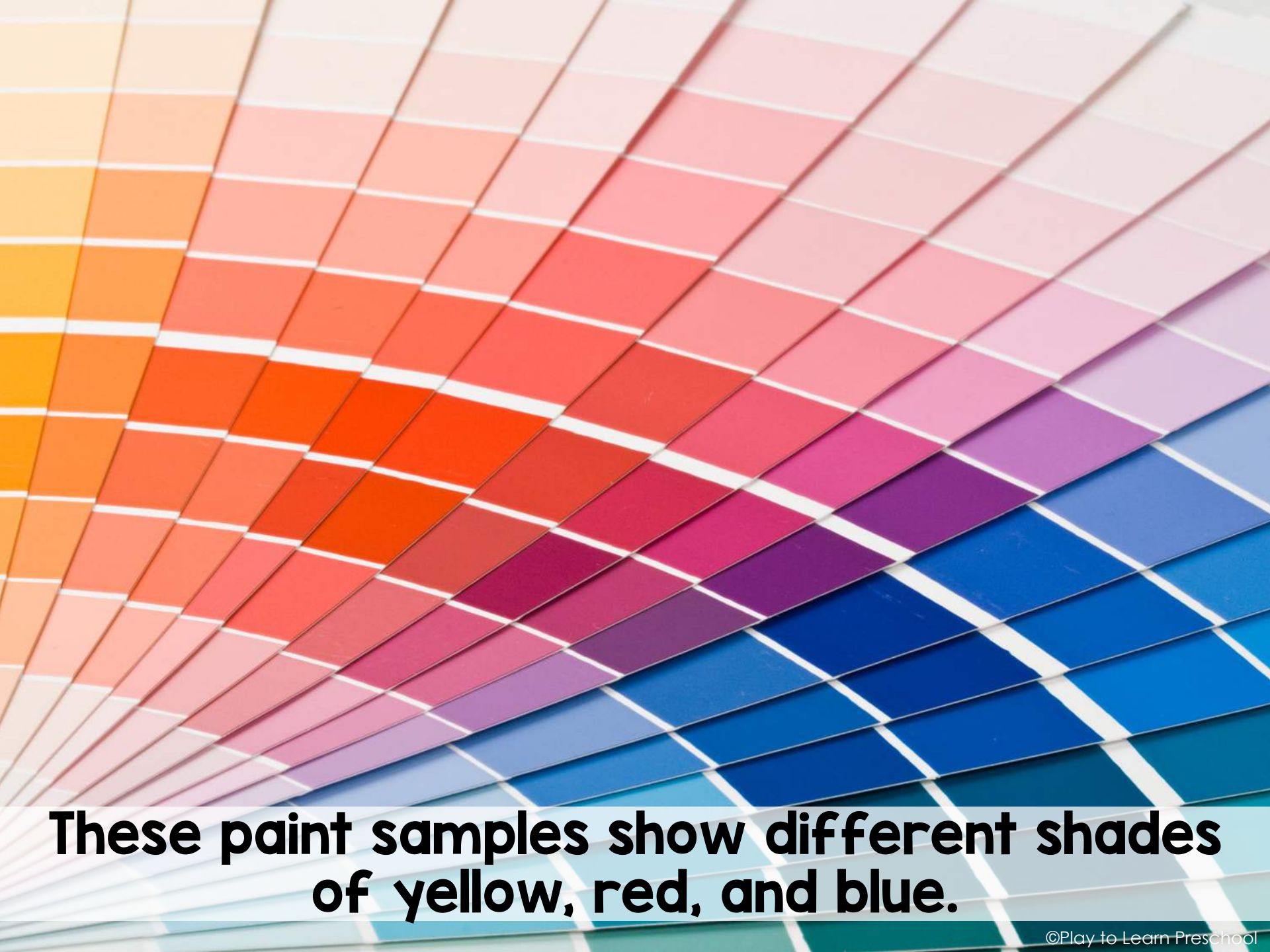

These paint samples show different shades of yellow, red, and blue.



How many shades of blue can you see?

Shade

Chant

Color **red**, color **red**, what do you think?
Add some white and I turn... **pink**!

Color **brown**, color **brown**, what's your plan?
Add some white and I turn... **tan**!

Color **black**, color **black**, what do you say?
Add some white and I turn... **gray**!

Color **orange**, color **orange**,
what do you teach?
Add some white and I turn... **peach**!

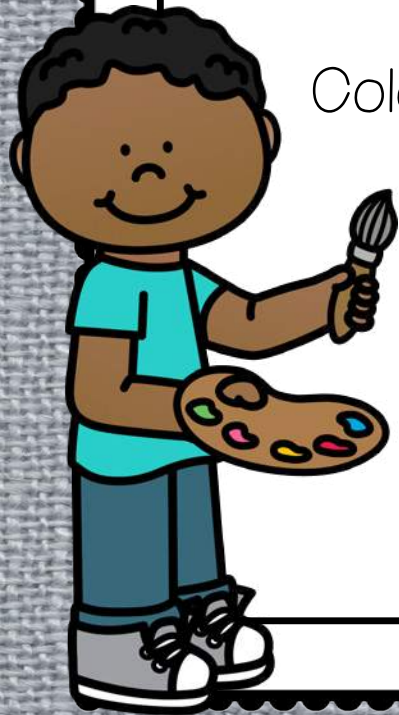

Color red, color red,
What do you think?

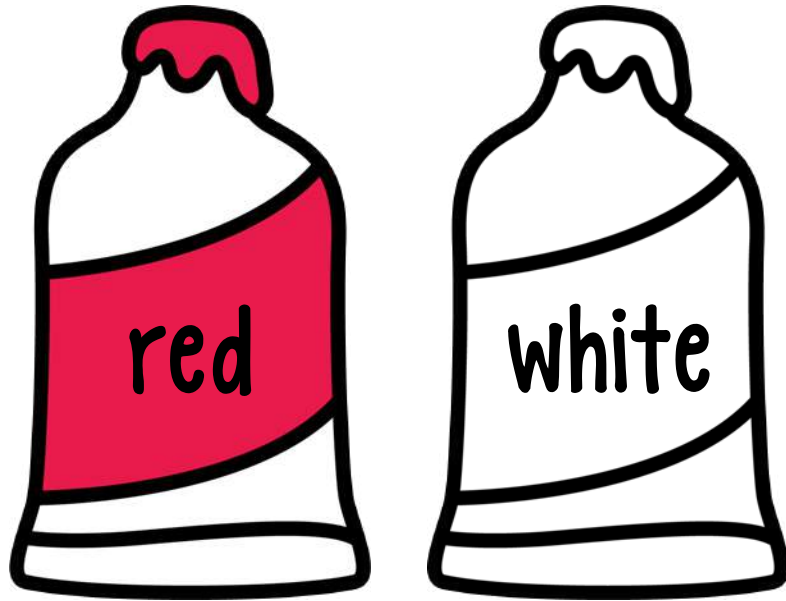

Add some white and I
turn...



Color brown, color brown,
What's your plan?



Add some white and I
turn...



Color black, color black,
What do you say?



Add some white and I
turn...



Color orange,
color orange,
What do you teach?



Add some white and I
turn...





shoe



balloon

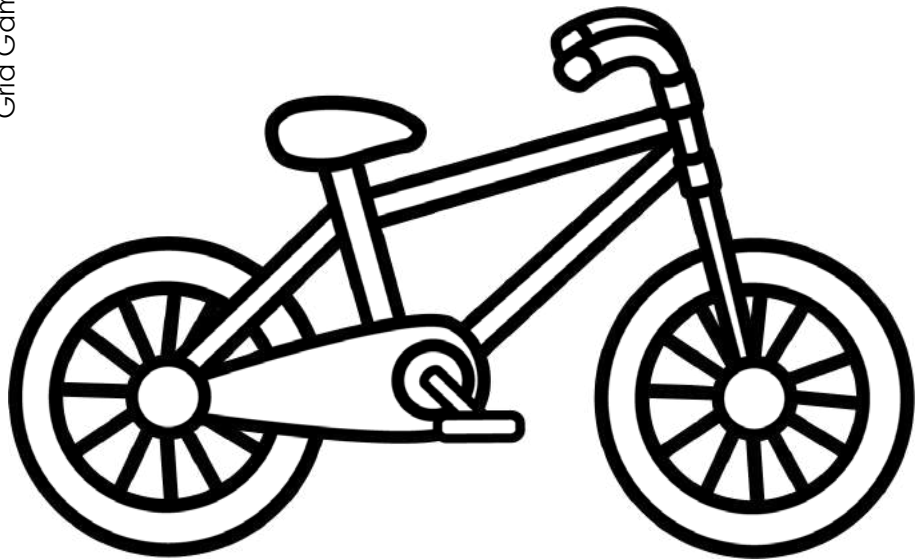

bike



chameleon

Changing Colors

Chameleon

Day 8
Lesson
Plans

The chameleon is a lizard that is able to change colors. They change colors so they can hide from predators.

Objectives:

- The students will notice similarities and differences and ask questions.
- The students will count down from five.
- The students will demonstrate an understanding of print concepts.

Activities:

1. Examine the real photos of chameleons. Talk about the different colors that are seen.
2. Chip clip "Chameleon on a Log".
3. Practice concept of word – "I See a Chameleon". Add each of the sentences to the pocket chart. Add the picture cards to help emergent readers remember each line.

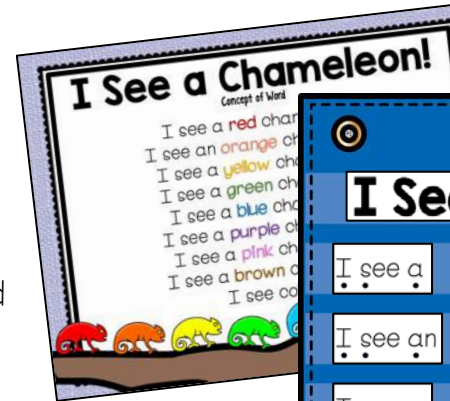
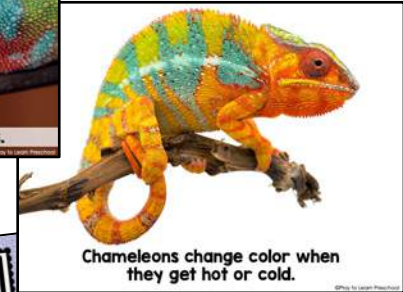

Extension Idea: Teach the ASL sign for "chameleon" by taking loose fingers and twisting them near your eyes. The sign mimics the bulge of the chameleon's eyes.

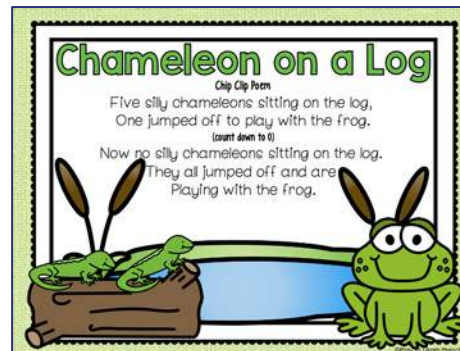
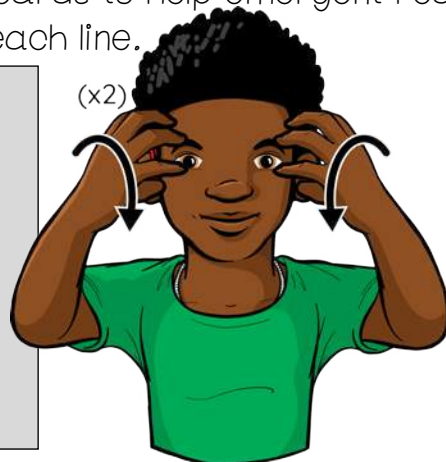



**Chameleons change color when
they get hot or cold.**



Chameleons come in many colors.

Chameleon on a Log

Chip Clip Poem

Five silly chameleons sitting on the log,
One jumped off to play with the frog.

(count down to 0)

Now no silly chameleons sitting on the log.
They all jumped off to
Play with the frog.



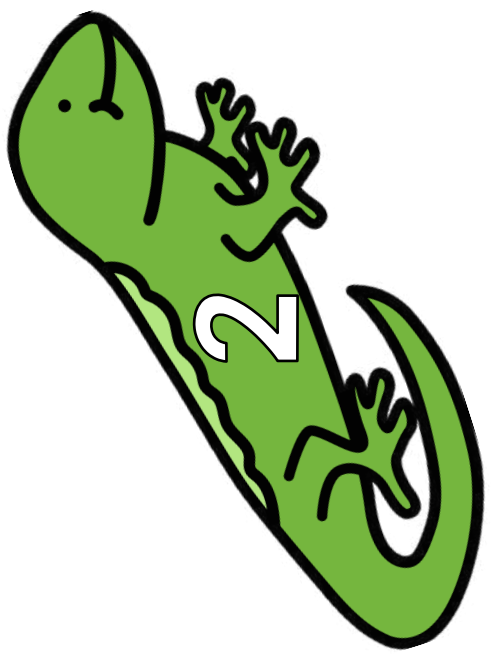

Chameleon on a Log

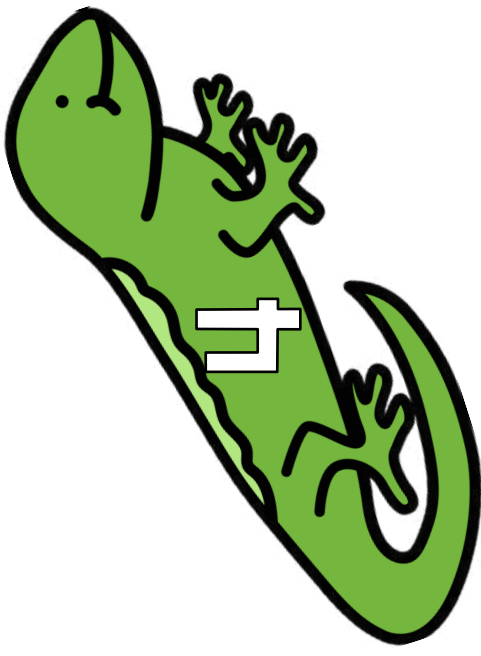

Chameleon on a Log

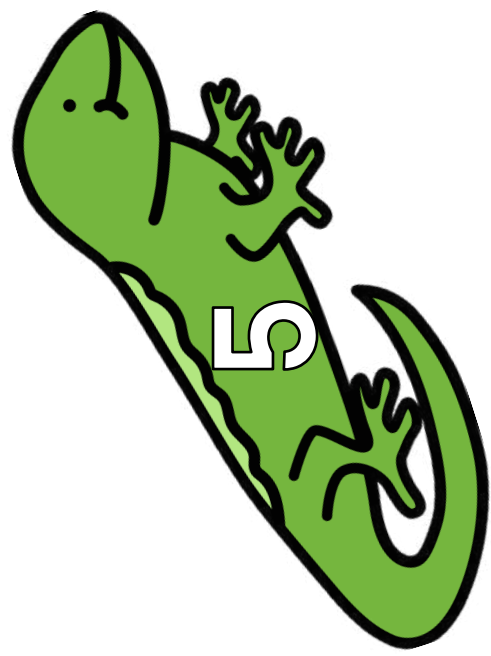

Chameleon on a Log

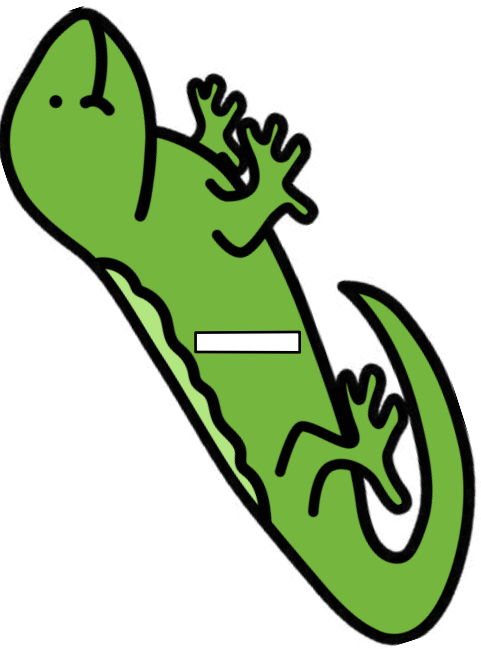

Chameleon on a Log

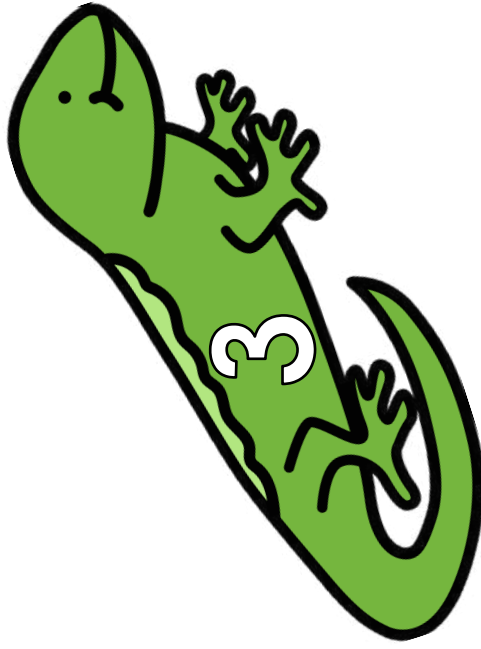

Chameleon on a Log

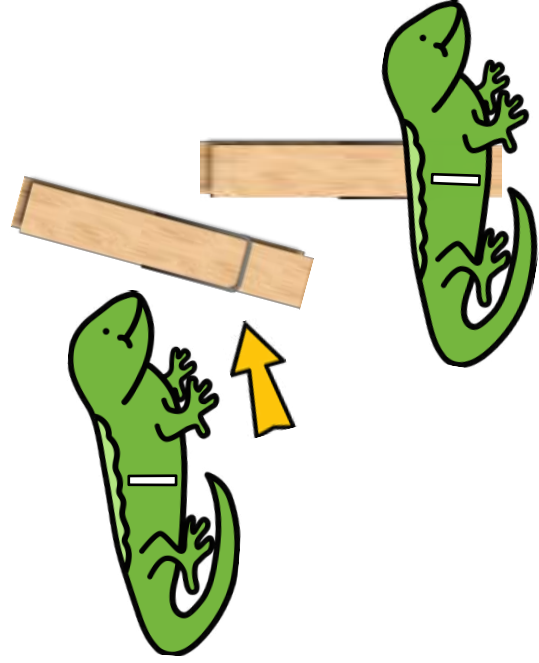

Chameleon on a Log

Chameleon on a Log



Five silly chameleons sitting on the log,
One jumped off to play with the frog.

(count down to 0)

Now no silly chameleons sitting on the log.
They all jumped off to play with the frog.

I See a Chameleon!

Concept of Word

I see a **red** chameleon.

I see an **orange** chameleon.

I see a **yellow** chameleon.

I see a **green** chameleon.

I see a **blue** chameleon.

I see a **purple** chameleon.

I see a **pink** chameleon.

I see a **brown** chameleon.

I see color!



I See a Chameleon

©Play to Learn Preschool

I see color!

I see a

red chameleon.

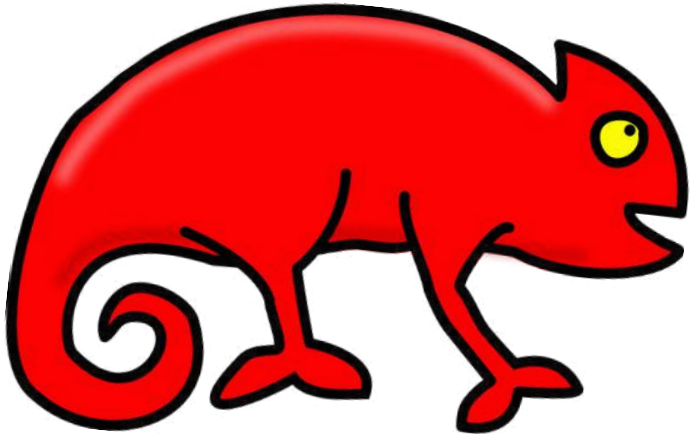

I see an

orange chameleon.

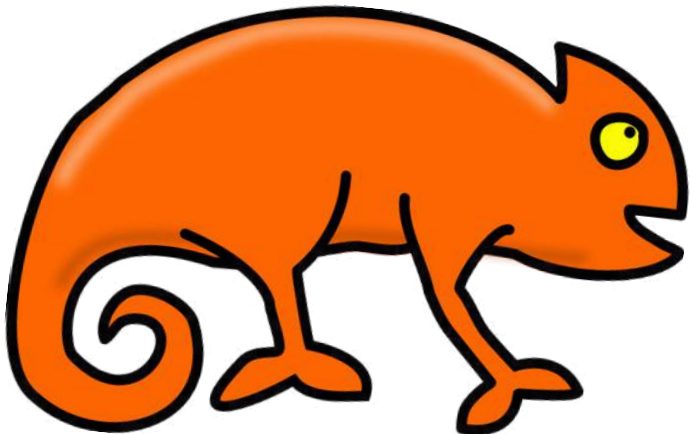

I see a

yellow chameleon.

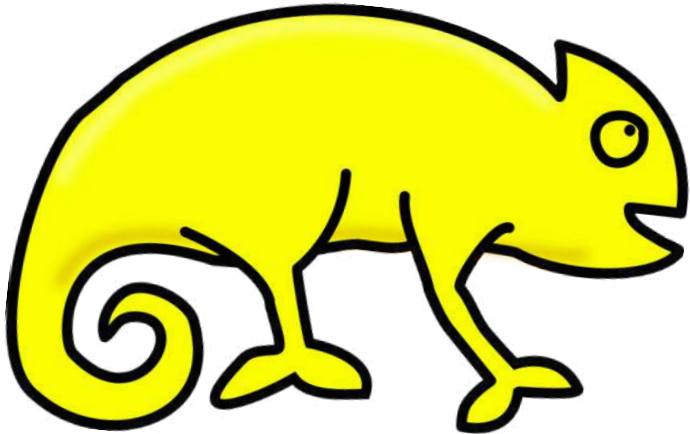

I see a

green chameleon.

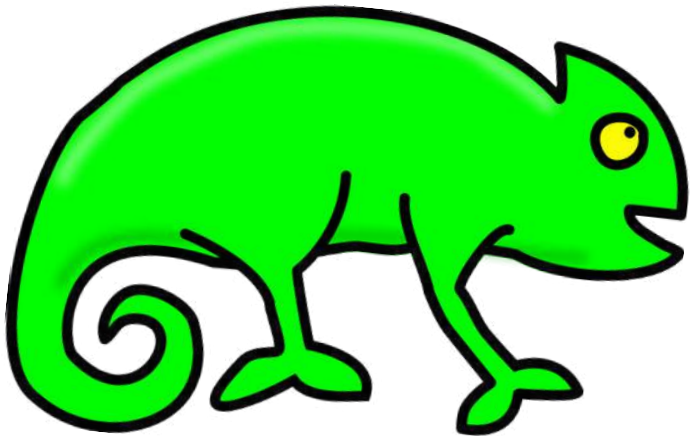

I see a

blue chameleon.

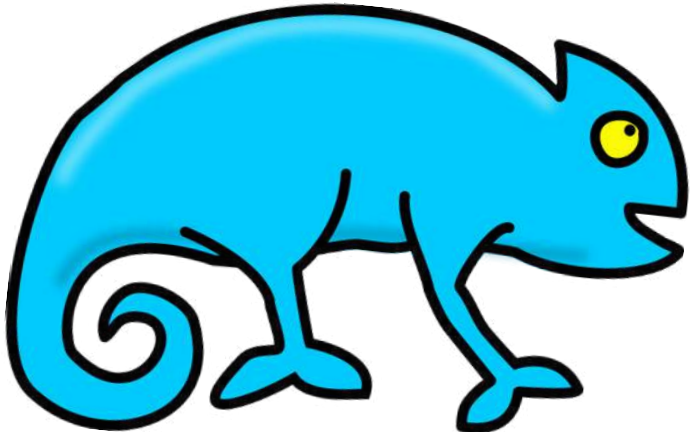

I see a

purple chameleon.

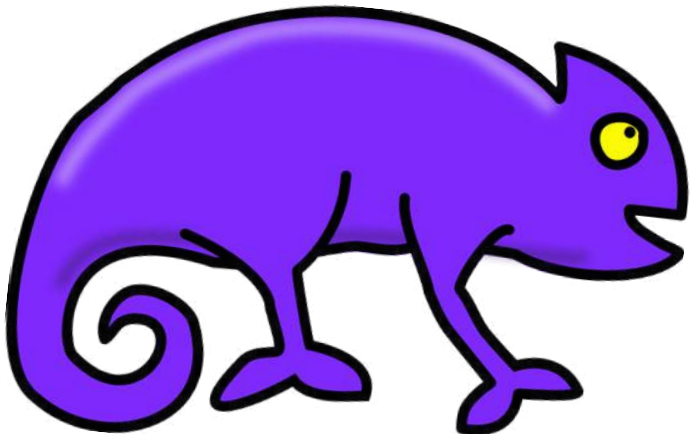

I see a

pink chameleon.

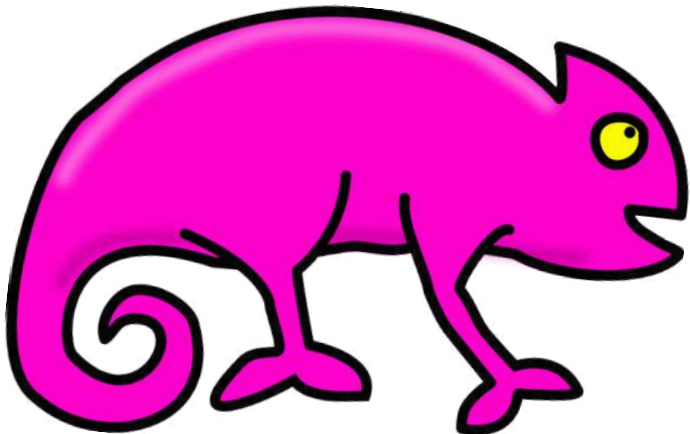

I see a

brown chameleon.

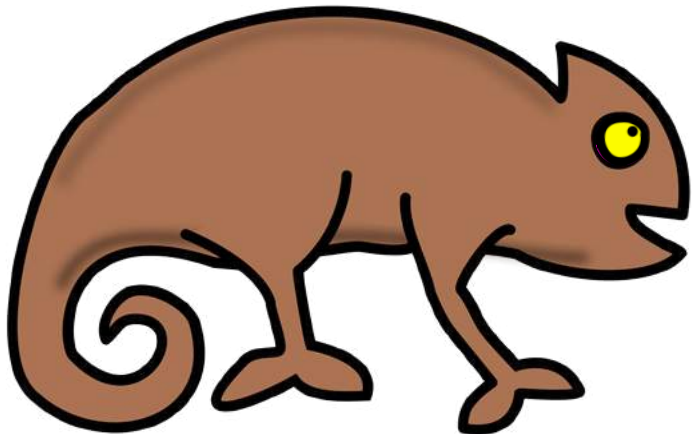

Festival of Colors

Holi Celebration

Day 9
lesson
plans

Some people celebrate Holi (hoh-lee) at the end of winter and beginning of spring. They sing, dance, eat yummy foods, and throw brightly colored powders in the air. The colors are beautiful!

Objectives:

- The students will use new vocabulary.
- The students will demonstrate basic locomotor skills.
- The students will share and take turns with others.

Activities:

1. Examine the real photos of Holi. Ask if anyone has ever participated in the celebration. What color powder do they like best?
2. Recite the Holi, Holi Dance. Use the cards to show what step is next.
3. Print off the "Guess it!" cards or place small, colorful toys in a box. (You could use a shoe box or tissue box.) Give each student a turn to take something out of the box and tell the class what color it is.

Extension Idea: Use spray bottles filled with different water colors to "paint" an old sheet or large piece of mural paper.

A great way of sharing Holi is to read *Festival of Colors* by Kabir and Sunishtha Sehgal.



Holi, Holi Dance
Celebration of Color and Spring
Holi, Holi, powder so red,
Pat your belly and nod your head.
Holi, Holi powder so yellow,
Shake yourself like a bowl of Jello.
Holi, Holi powder so green,
Wash your hands 'til they're nice.
Holi, Holi powder so blue,
Spin around and show you're new.
Holi, Holi powder so purple,
Walk - slow - like a turtle.
Holi, Holi powder so pink,
Smile, then give a wink!

Guess It! Box
Reach right in and pull one out.
Tell us what it's all about.
What color did you pick?

Stamp your feet and show your rhythm!

Show a smile, then give a wink!

Pat your belly and nod your head.

green

brown

purple



Holi is the festival of colors. It marks the beginning of spring with bright powders.



People celebrate Holi by throwing colorful powder called gulal in the air .



People come together and throw gulal, eat sweets, dance, and sing folk music during Holi.

Holi, Holi Dance

Celebration of Color and Spring

Holi, Holi powder so red,
Pat your belly and nod your head.

Holi, Holi powder so yellow,
Shake yourself like a bowl of Jell-O.

Holi, Holi powder so green,
Wash your hands 'till they're nice and clean.

Holi, Holi powder so blue,
Stomp around and show your shoe.

Holi, Holi powder so purple,
Walk - slow - like a turtle.

Holi, Holi powder so pink,
Show a smile, then give a wink!

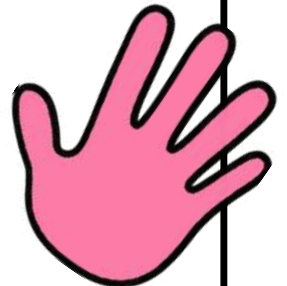
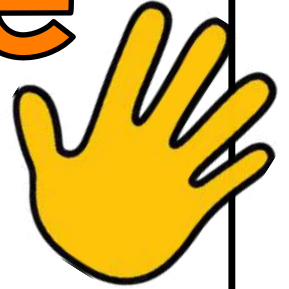
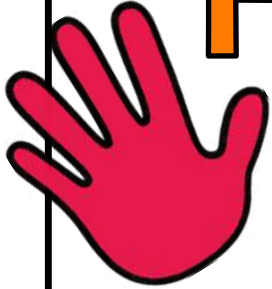



Pat your belly and nod your head.



Shake yourself like a bowl of Jell-O.



Wash your hands 'till they're nice and clean.

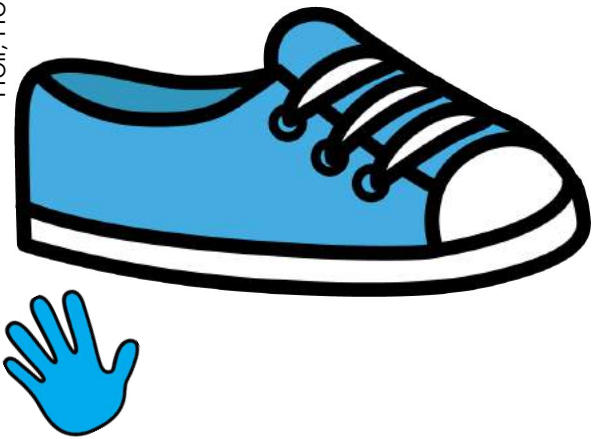

Stomp around and show your shoe.

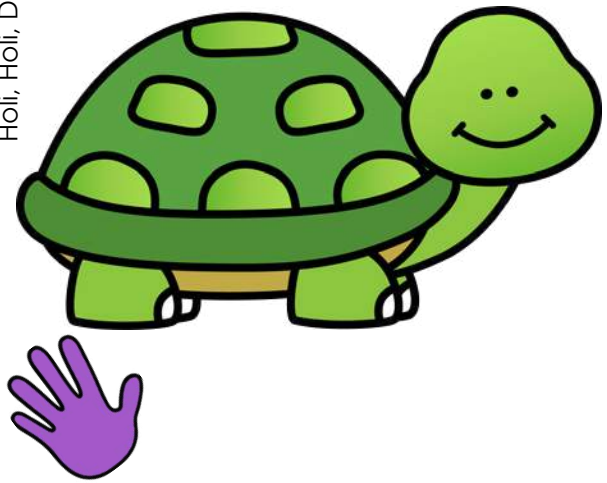

Walk – slow – like – a – turtle.



Show a smile, then give a wink!

Guess It! Box

Reach right in and pull one out.
Tell us what it's all about.

What color
did you pick?

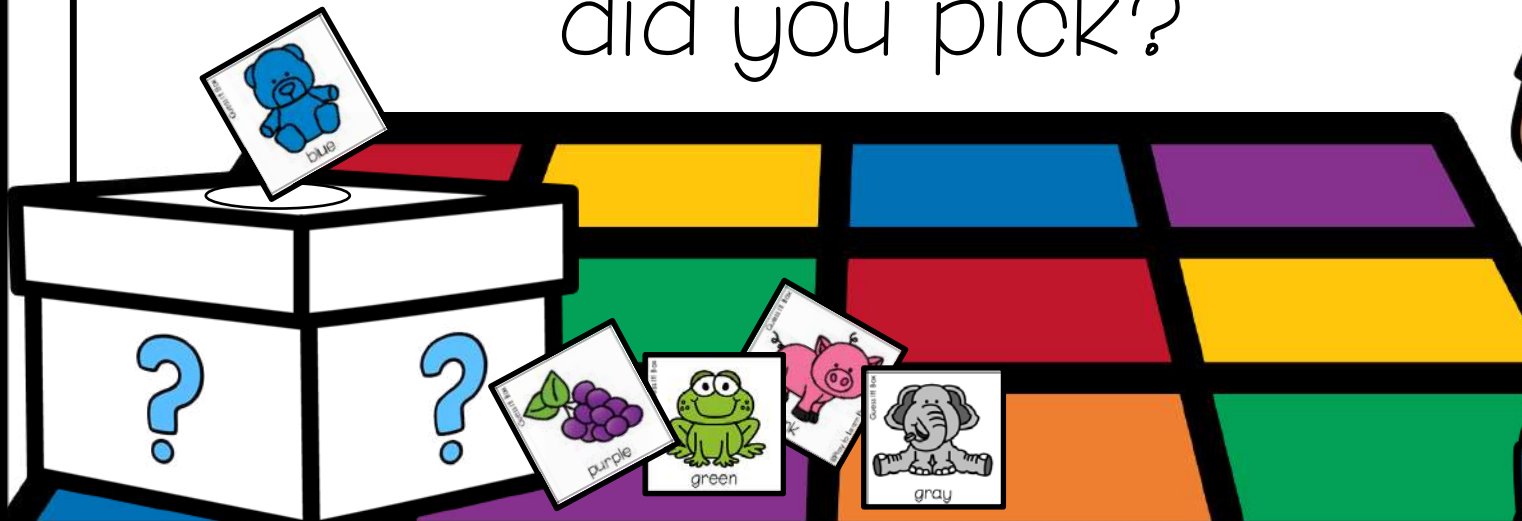

Guess It! Box

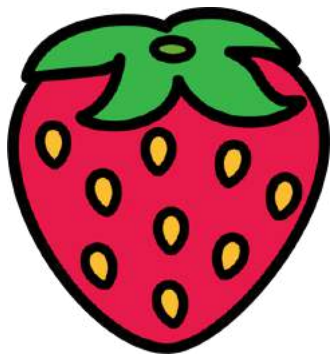

red

Guess It! Box



orange

Guess It! Box

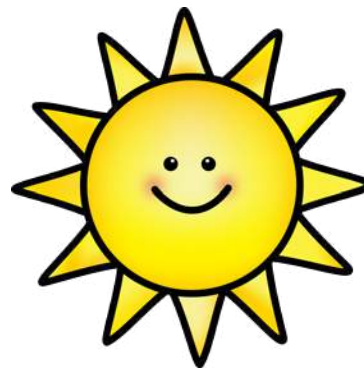

yellow

Guess It! Box

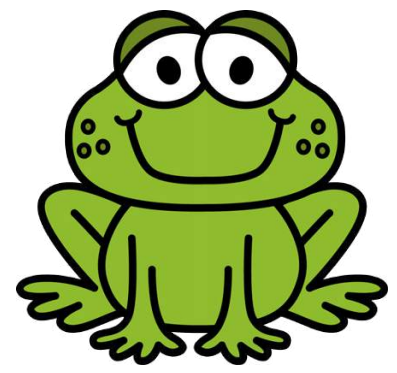

green

Guess It! Box

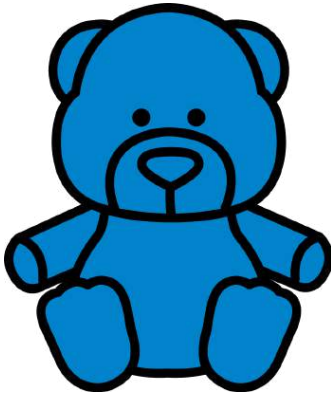

blue

Guess It! Box

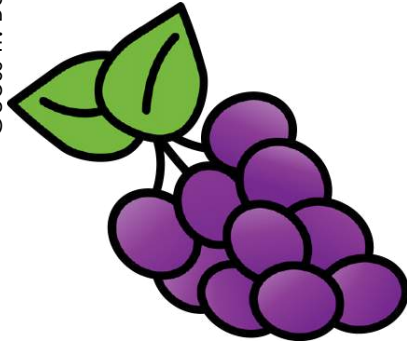

purple

Guess It! Box



black

Guess It! Box



white

Guess It! Box



brown

Guess It! Box

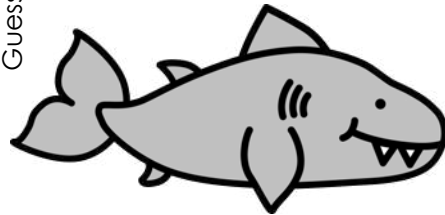

gray

Guess It! Box



tan

Guess It! Box

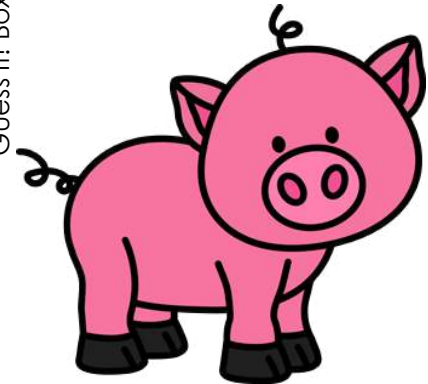

pink

Conclusion

Unit Conclusion

Day 10
lesson
plans

To conclude the unit, ask the students to describe what they have learned about colors. Is their favorite color the same as when the unit started?

Objectives:

- The students will express themselves using words and sentences.
- The students will interact and participate in circle time.

Activities:

1. Invite students to list the things they have learned about colors. Write the ideas on index cards or on the crayon box tags provided.
2. Create riddle bags. Place a small colored toy (or star card provided) in each bag and affix the coordinating riddle to the outside of the bag. Read the riddle while the students practice their active listening skills. They guess what color is in the bag, then check inside!

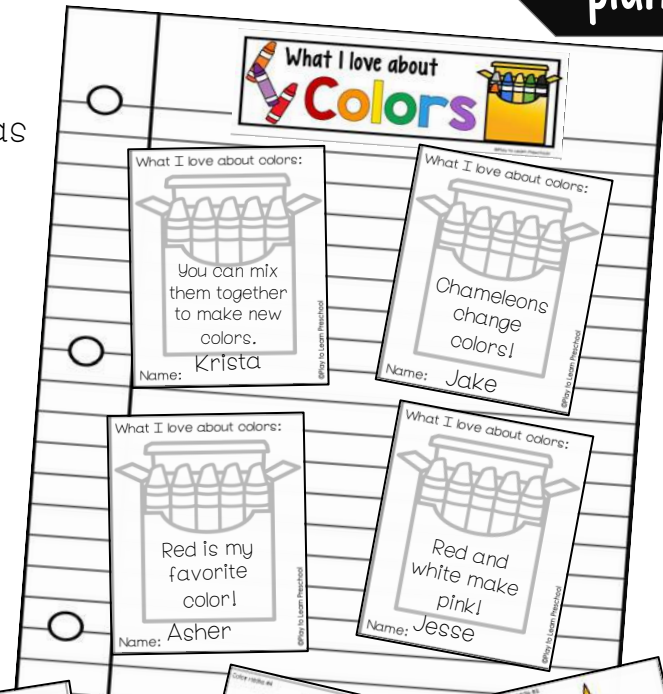

Extension Idea: Use eye droppers and colored water to explore color theory.
<https://playtolearnpreschool.us/color-theory/>



Riddle #1

I am a primary color.
Cherries, apples,
strawberries, and roses
can be this color.

Answer: red

Riddle #2

I am a secondary color.
Basketballs, pumpkins,
carrots, and tigers can be
this color.

Answer: orange

Riddle #3

I am a primary color.
Sunflowers, bananas,
lemons, school buses, and
rubber duckies can be this
color.

Answer: yellow

Riddle #4

I am a secondary color.
Frogs, leaves, turtles, and
lettuce can be this color.

Answer: green

Riddle #5

I am a primary color.
Berries, jeans, the sky, and
the ocean can be this
color.

Answer: blue

Riddle #6

I am a secondary color.
Grapes, eggplant, flowers,
and jelly can be this color.

Answer: purple

Riddle #7

I am a light shade of red.
Pigs, flamingos, bubble gum,
and cotton candy can be
this color.

Answer: pink

Riddle #8

I am the darkest color of
all. Bats, cats, pandas, and
zebras have this color on
them.

Answer: black

Riddle #9

I am the lightest color.
Snow, paper, sugar, and
milk are this color.

Answer: white

Riddle #10

I am an earthy color.
Trees, chocolate, pretzels,
and bears can be this
color.

Answer: brown

Riddle #11

I am a lighter shade of
brown. Lions, giraffes,
camels, and deer can be
this color.

Answer: tan

Riddle #12

I am a very light shade of
black. Elephants, dolphins,
rocks, and clouds can be
this color.

Answer: gray

Color riddle #1



red

Color riddle #2

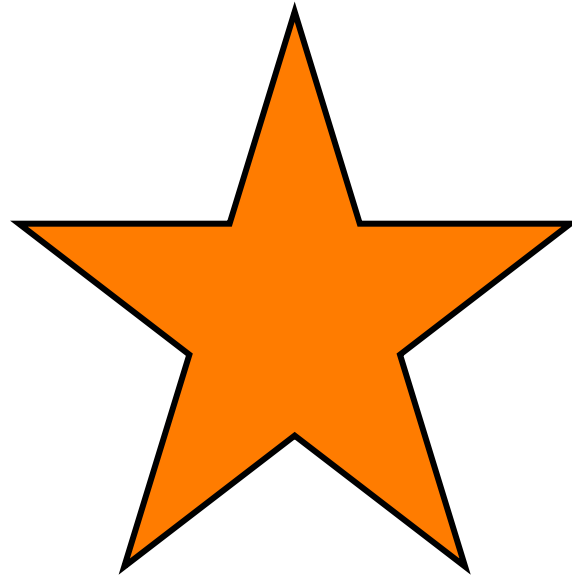

orange

Color riddle #3



yellow

Color riddle #4

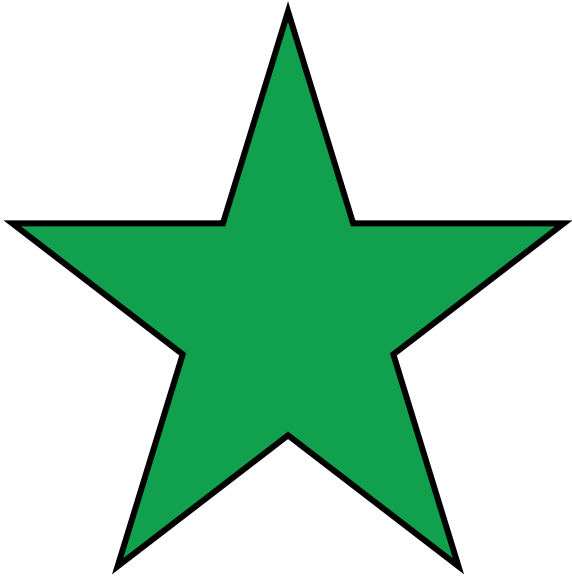

green

Color riddle #5

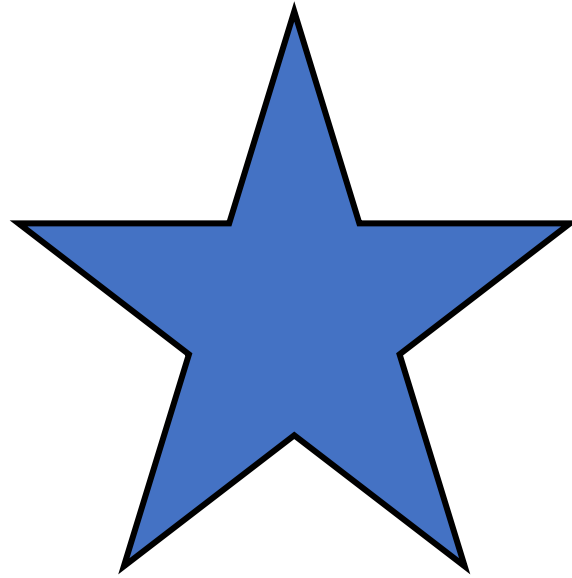

blue

Color riddle #6

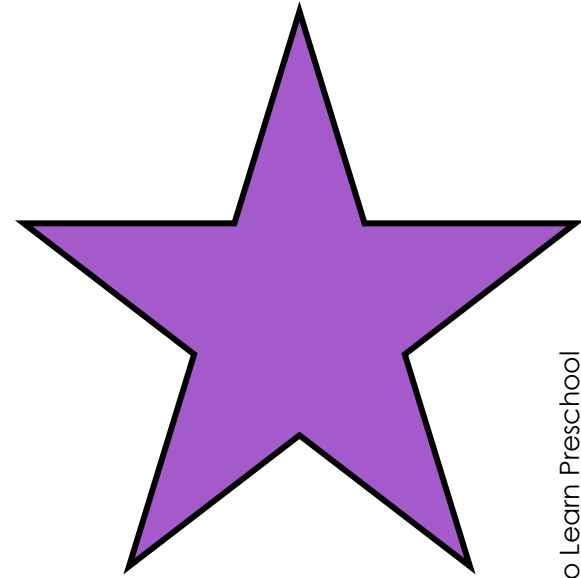

purple

Color riddle #7

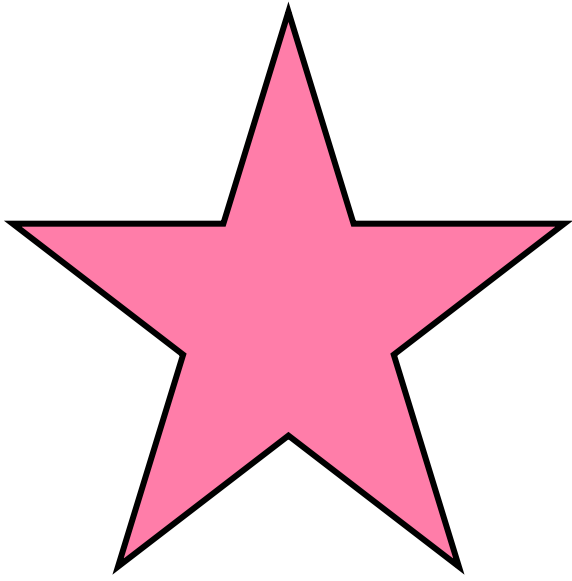

pink

Color riddle #8

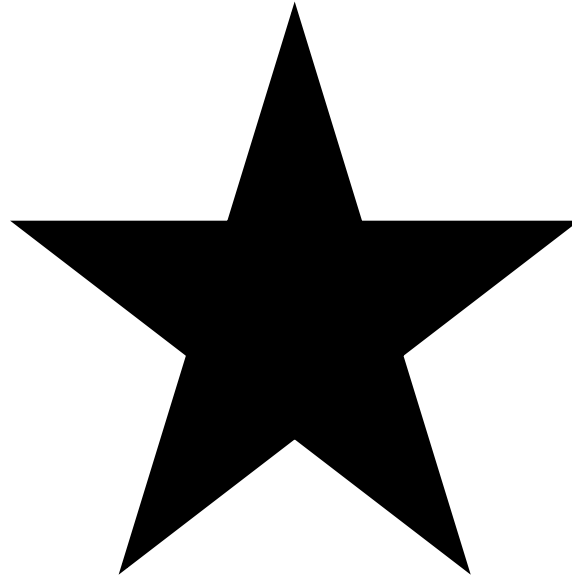

black

Color riddle #9

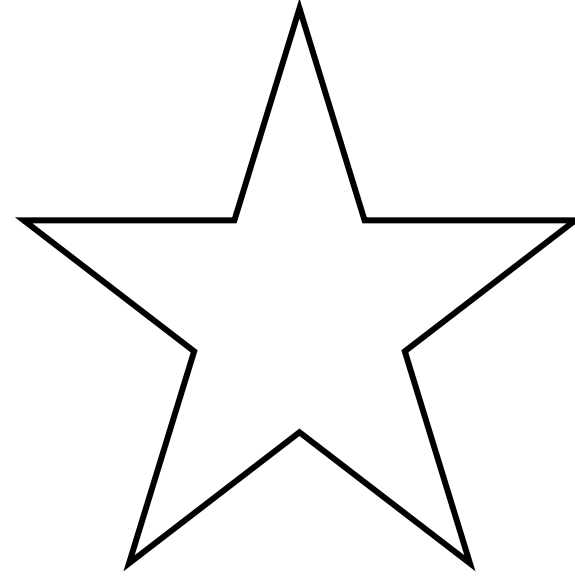

white

Color riddle #10

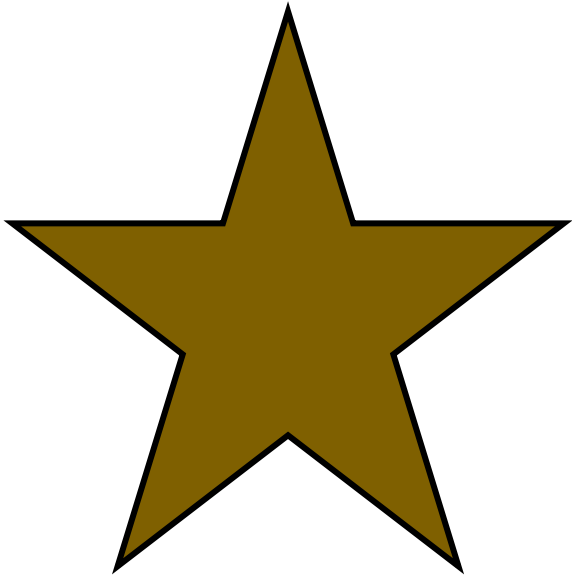

brown

Color riddle #11

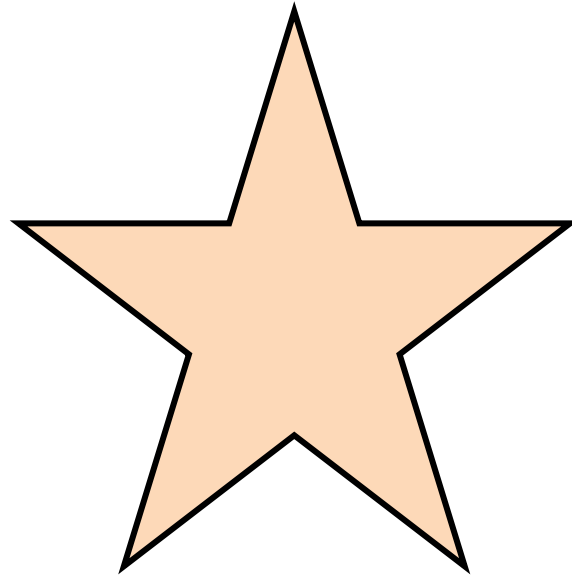

tan

Color riddle #12

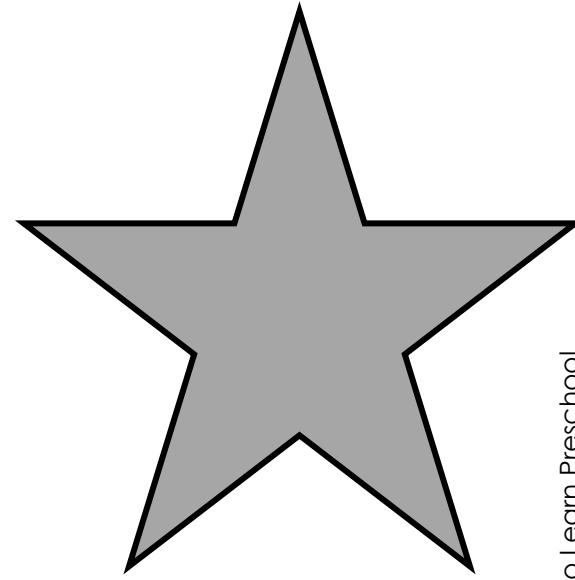

gray

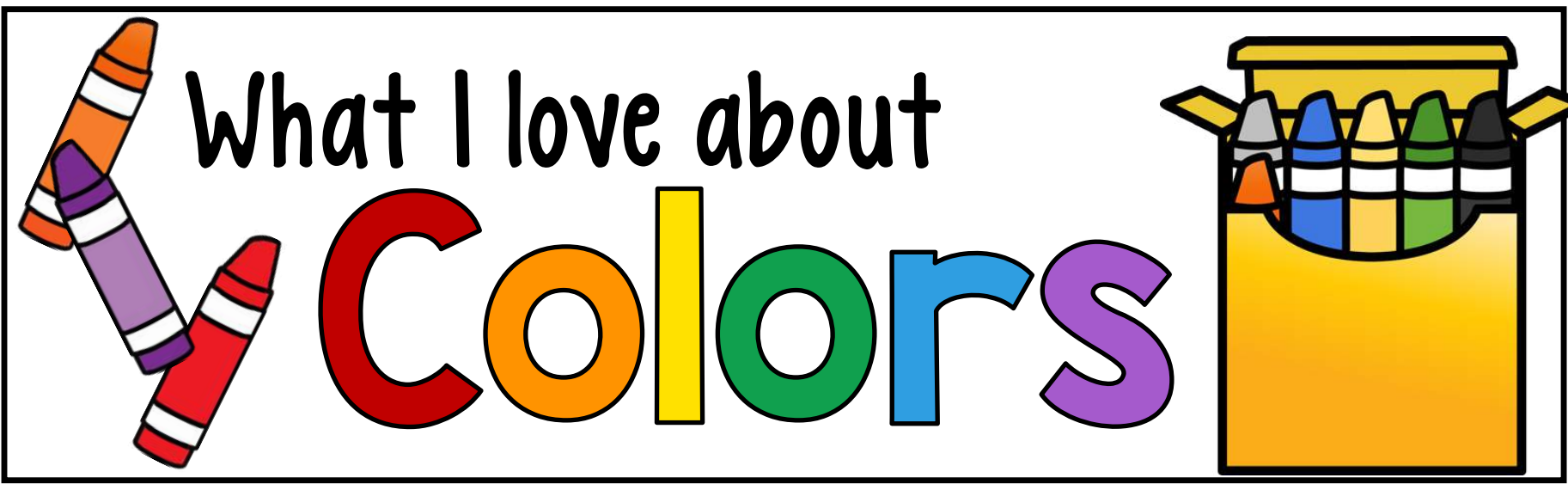

What I love about colors:

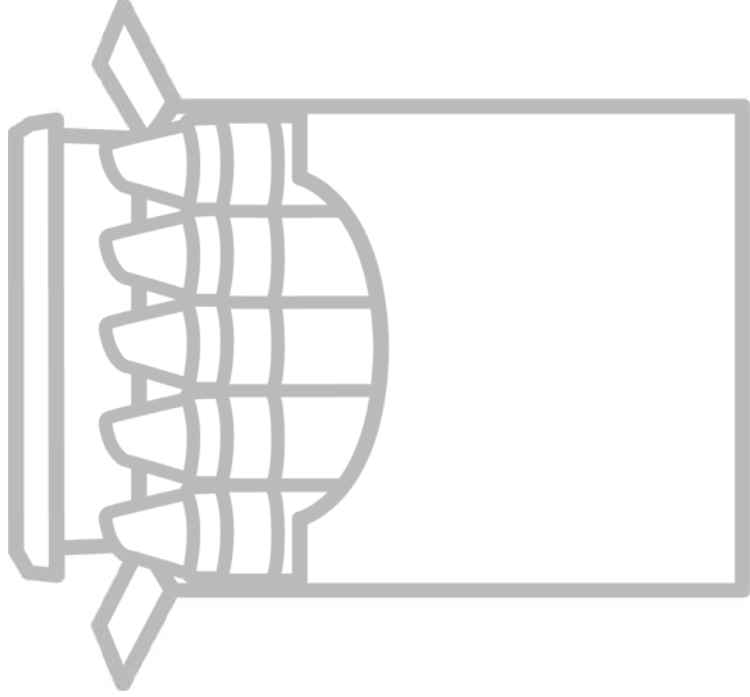

Name:

What I love about colors:

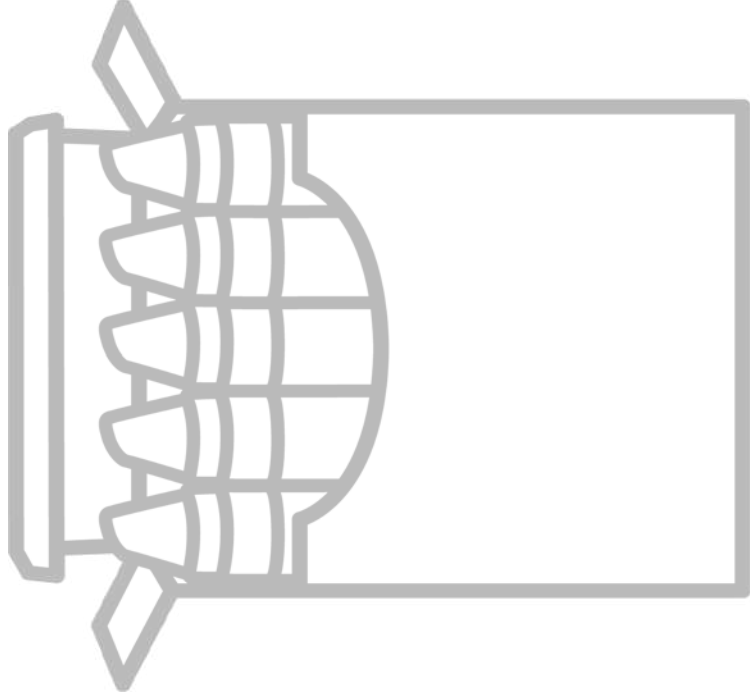

Name:

What I love about colors:

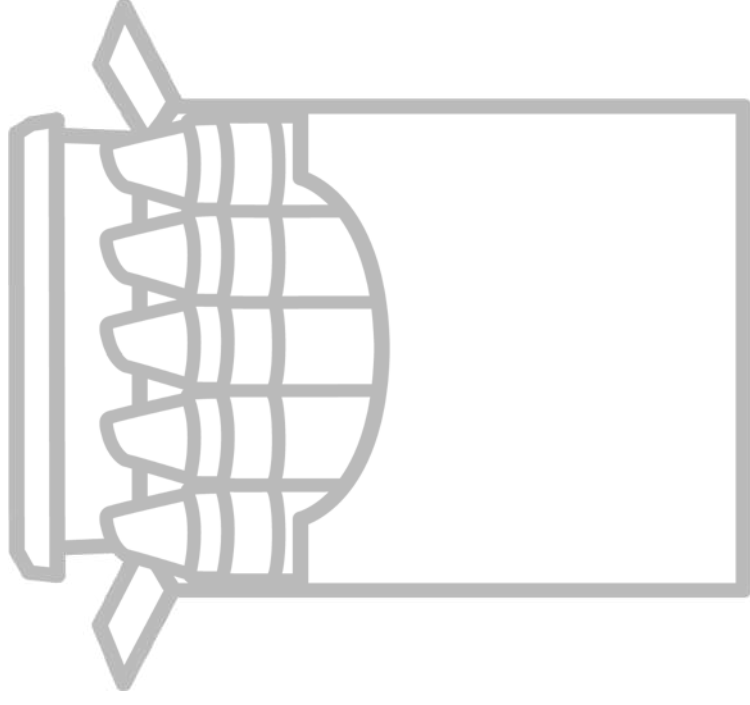

Name:

What I love about colors:

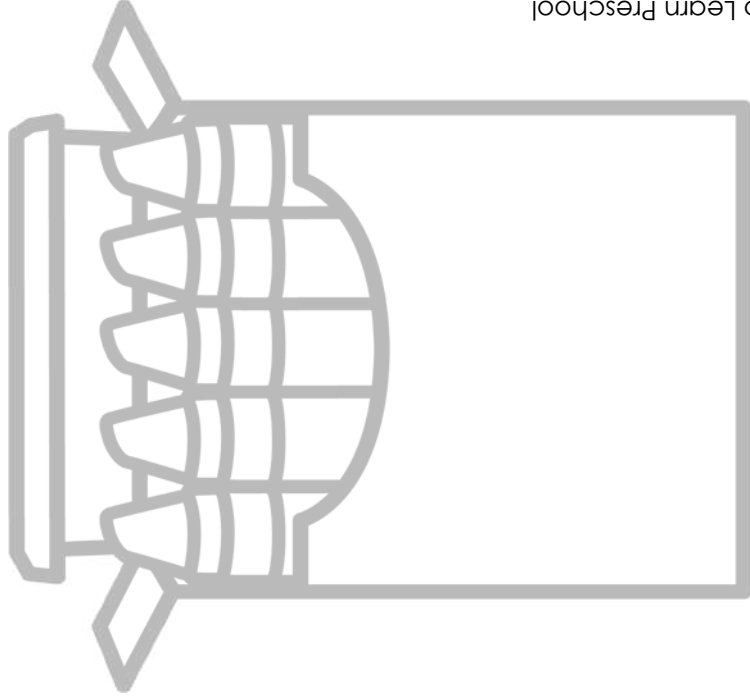

Name:

Center Activities

Centers

- Cutting Practice
- Line Tracing
- Rhyming Rainbows
- Writing Practice
- Journaling
- Counting Folder Game
- Beginning Sound Sort
- Color Sorting
- Count & Clip Cards
- Concentration
- Book List (Recommendations)

Cutting Practice

Objective: The students coordinate eye-hand movement and control the small muscles in their hands.

Preparation: Print a cutting page for each student. Demonstrate proper scissors usage and guide out along the line from the bottom to the top.

Procedure: The students will cut along the line.

Line Tracing

Objective: The students will understand the purpose of writing.

Preparation: Print and laminate these tracing cards. Another option is to place them inside a plastic sleeve. Provide dry erase markers. (Glue a pom-pom onto the lid of the marker for the students to use as an eraser.)

Procedure: Trace the lines.

Rhyming Rainbows

Objective: The students identify rhyming words.

Preparation: Copy each puzzle, laminate and cut apart.

Procedure: Students say the name of the picture on the left side of the rainbow and find the rhyming picture on the right side of the rainbow.

Writing Practice

Objectives: The students will write letters.

Preparation: Copy each page and place into a plastic sleeve (or print on cardstock and laminate).

Procedure: Students use a dry erase marker to trace the word.

Journaling

Objective: The students will understand the purpose of writing.

Procedure: Print the journal sheets. Students can use the journal prompt to write and draw a picture. The words can also be written for the student if necessary.

Counting

File Folder Game

Objective: The students will count and recognize numbers.

Preparation: Copy the picture cards. Glue the large pictures (first 2 pages) inside a file folder. Cut and laminate the smaller pictures.

Procedure: Students will count and choose the correct number.

Beginning Sound Sort

File Folder Game

Objectives: The students will identify the beginning sound of each word.

Preparation: Copy the picture cards, glue the cover on the front of the file folder and the sorting mats on the inside. Cut and laminate the smaller pieces.

Procedure: Students sort the pictures by their beginning sound.

Count and Clip Cards

Objective: Students will practice one-to-one correspondence and number recognition to 12.

Preparation: Print the cards, mat, laminate and cut apart.

Procedure: Students count the pictures on each card and mark the correct answer with a clothes pin.

Color Sorting

Objective: The students will sort food pictures by color onto the matching color plate.

Preparation: Print the colored plates or use the black and white plate to copy paper. Print, laminate and cut apart the food pictures.

Procedure: Students look at the food and identify its color. They place the food on the matching plate.

Concentration

Objectives: The students will use visual discrimination (matching) skills to identify two identical objects.

Preparation: Print the picture cards. Mat on cardstock and/or laminate as desired. Cut apart.

Procedure: Place cards facing down. Students take turns flipping over 2 cards at a time. If the cards match, the student gets to keep the pair. If they don't match, they return them to the face-down position and try again.

Cutting Practice

Objective: The students coordinate eye-hand movement and control the small muscles in their hands.

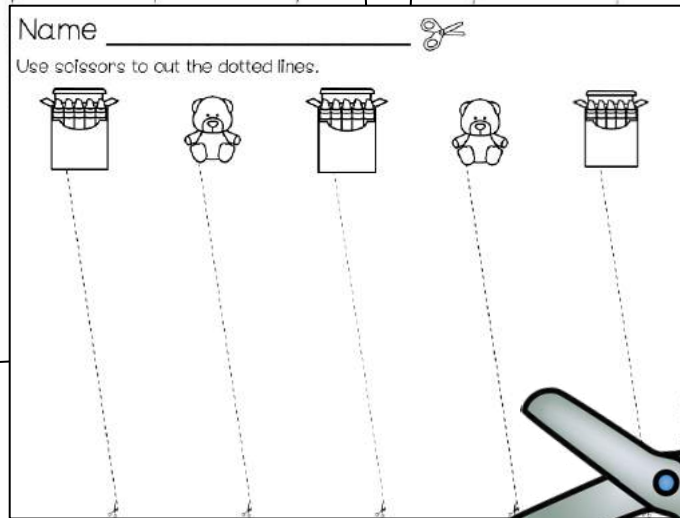
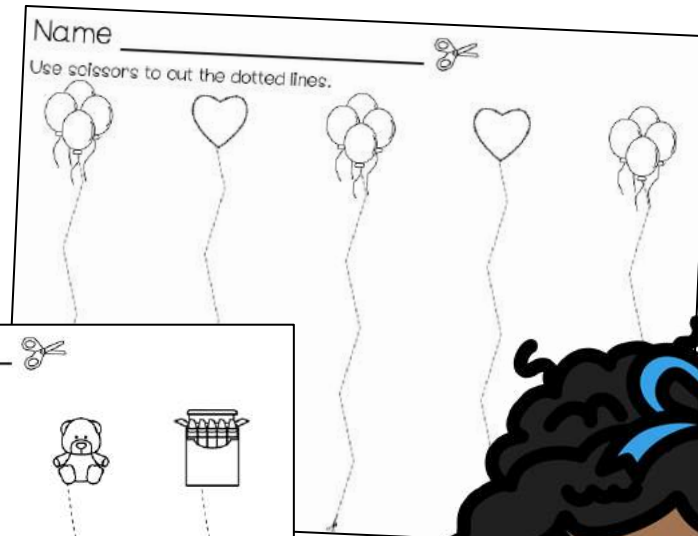
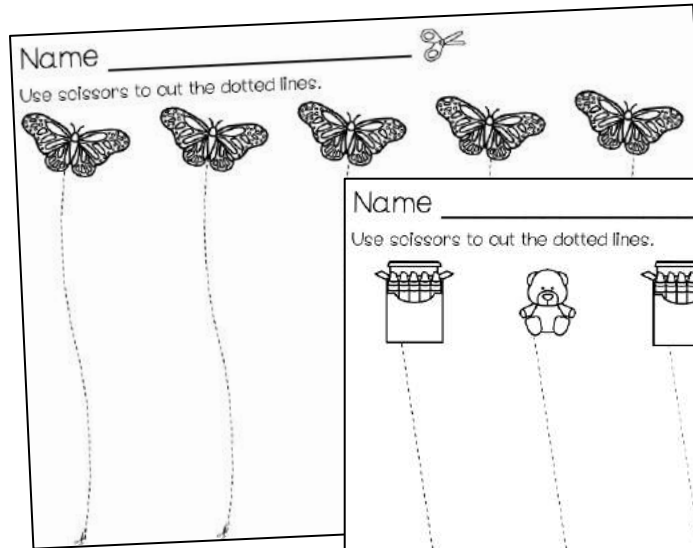

Preparation: Print a cutting page for each student. Demonstrate proper scissors usage and guide students to cut along the lines from the bottom to the top.

Procedure: The students will cut along the dotted lines from the bottom of the page to the top.

Name _____



Use scissors to cut the dotted lines.

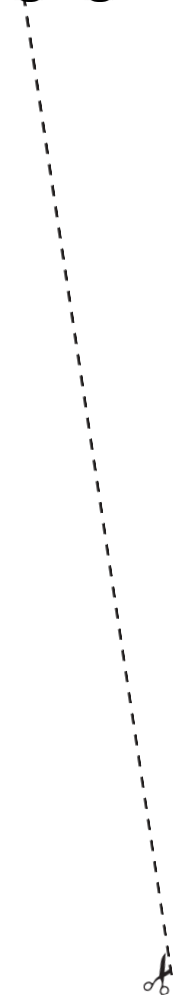
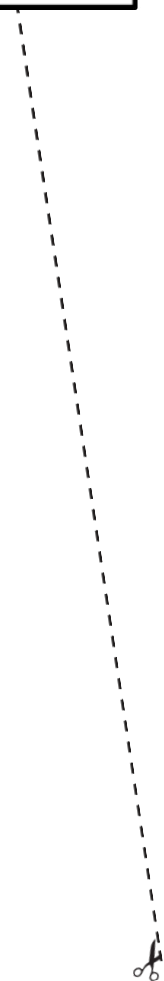
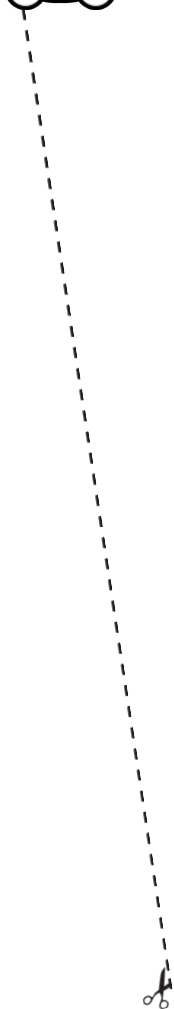
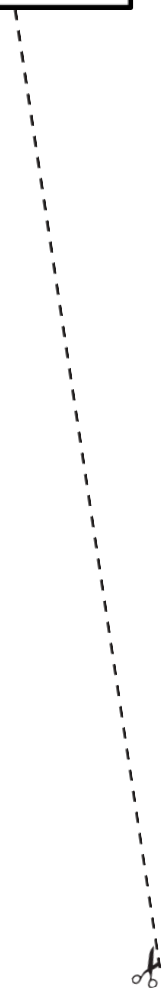
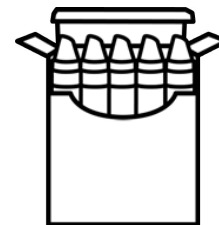
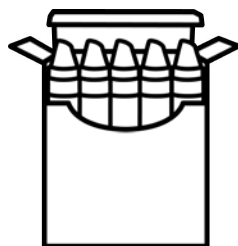
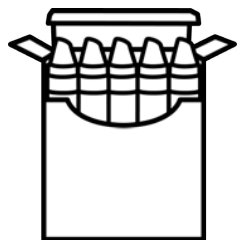

Name _____



Use scissors to cut the dotted lines.

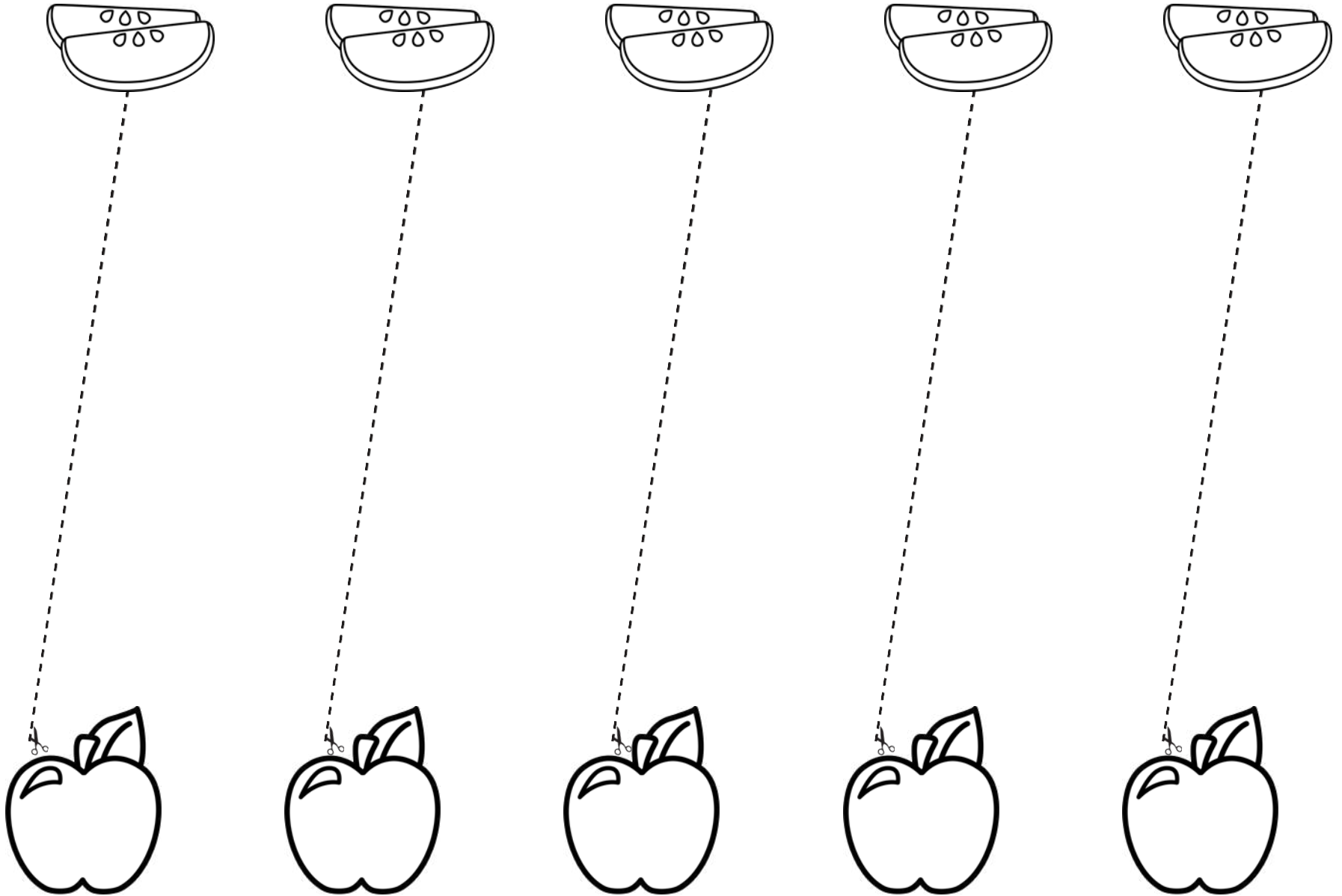

Name _____



Use scissors to cut the dotted lines.



Name _____



Use scissors to cut the dotted lines.

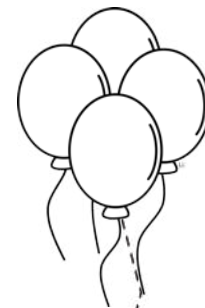
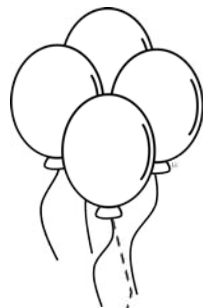
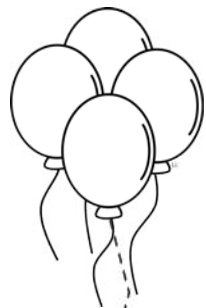

Line Tracing

Objective: The students will understand the purpose of writing.

Preparation: Print and laminate these tracing cards. Another option is to place them inside a plastic sleeve. Provide dry erase markers. (Glue a pom-pom onto the lid of the marker for the students to use as an eraser!)

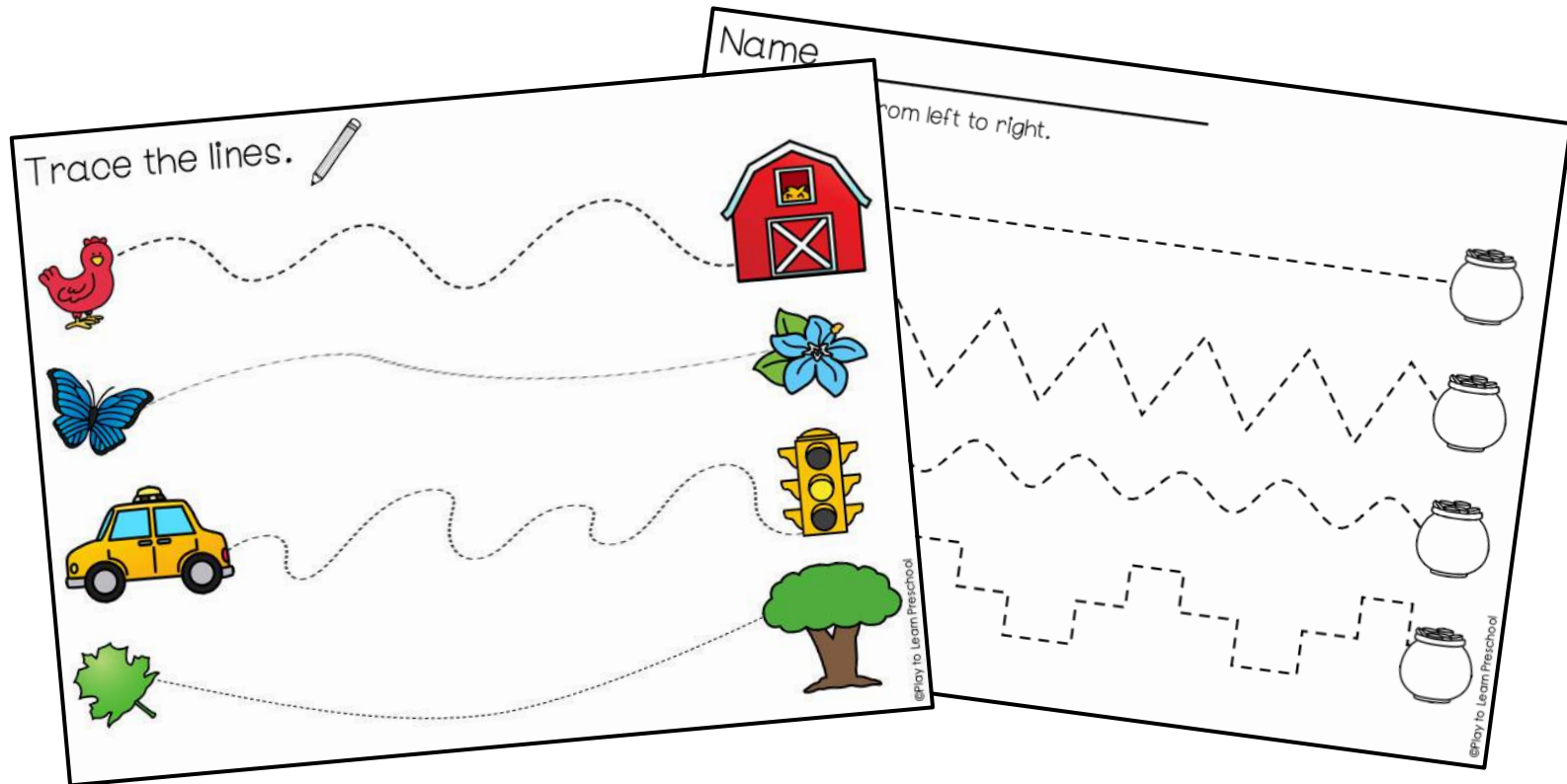

Procedure: The students will trace the dotted lines from left to right to practice fine motor skills.

Trace the lines.

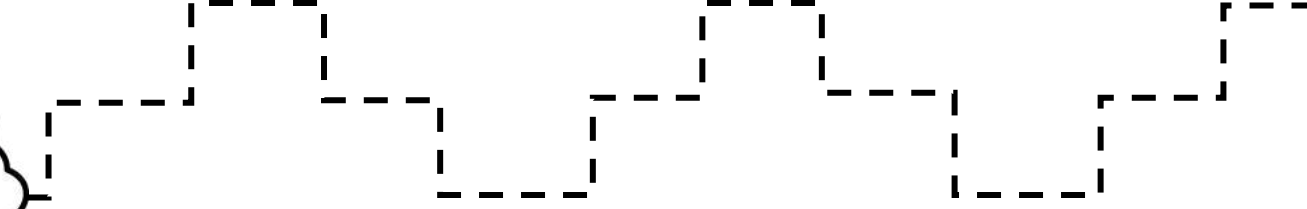
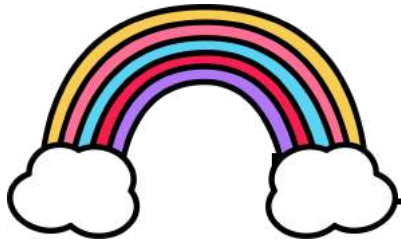
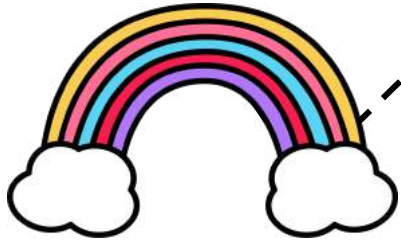
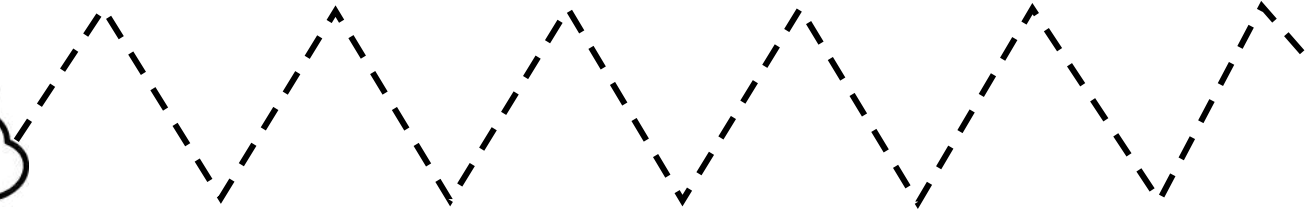
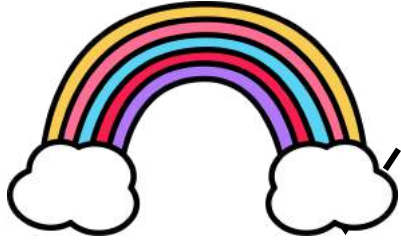
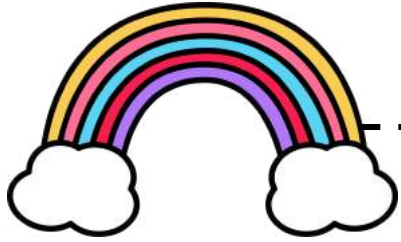

Trace the lines. 

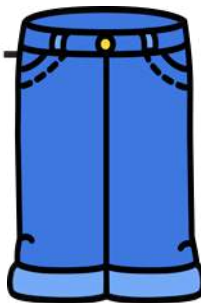
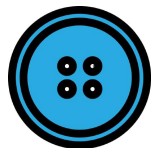
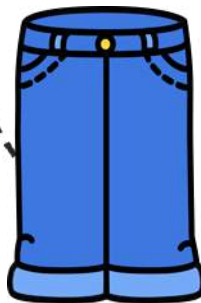
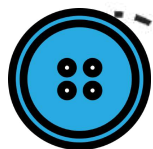
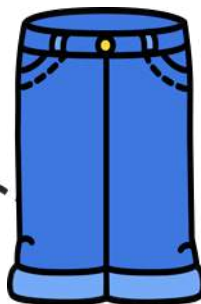
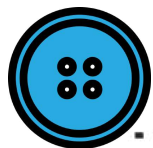
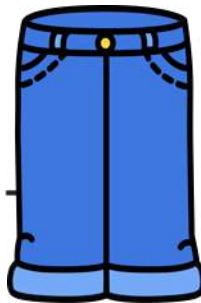
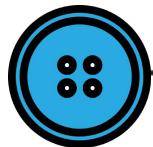

Trace the lines.

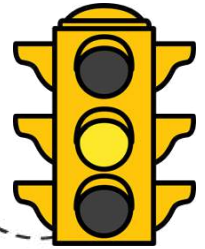
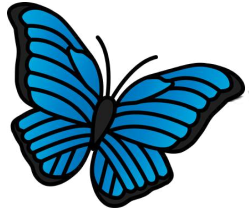
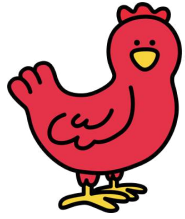

Trace the lines.

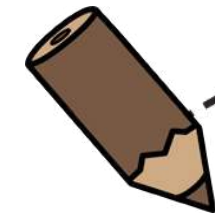
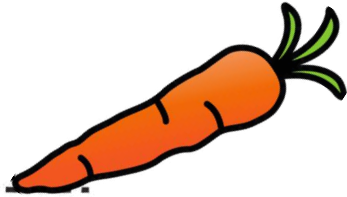
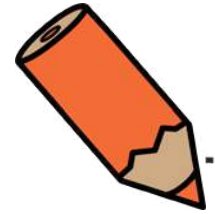
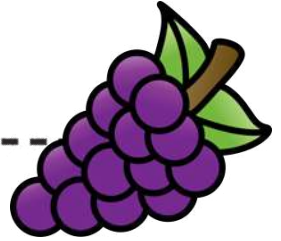
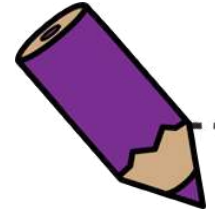
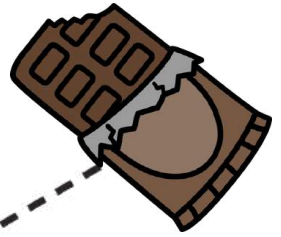

Trace the lines.

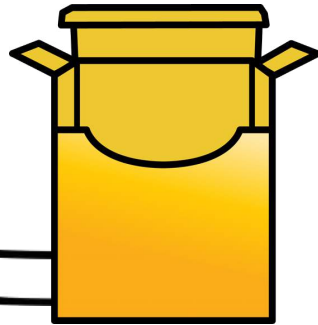
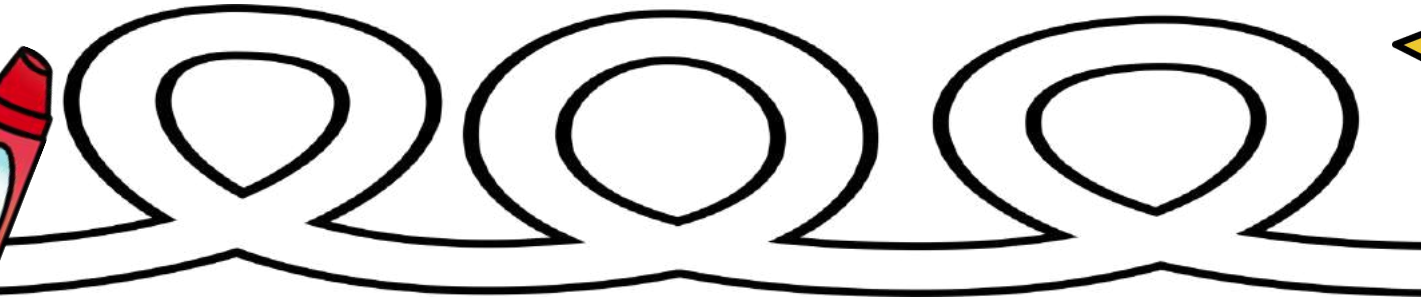
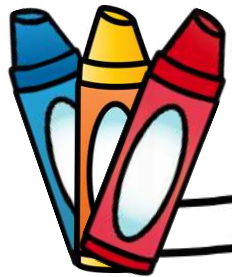
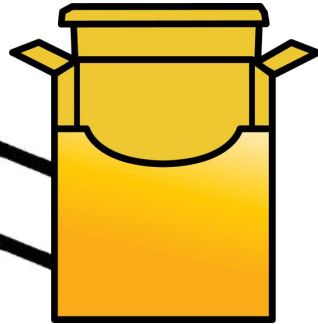
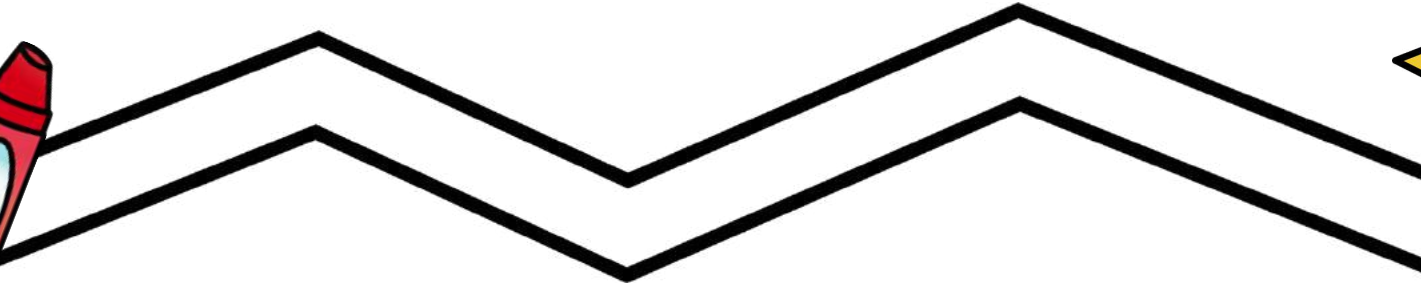
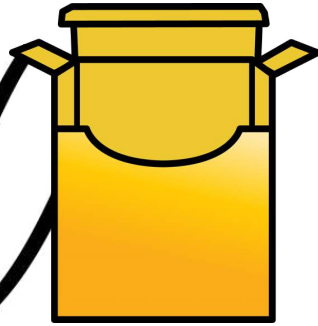
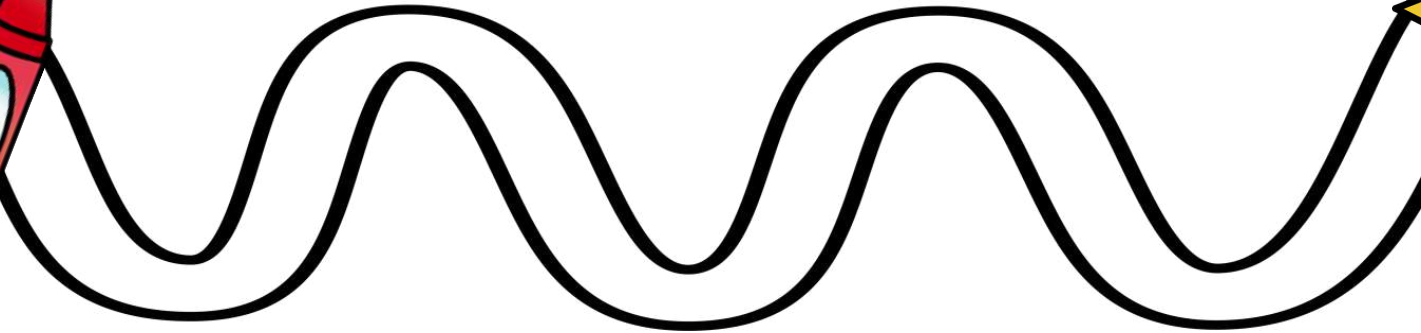

Name _____

Trace the line from left to right.

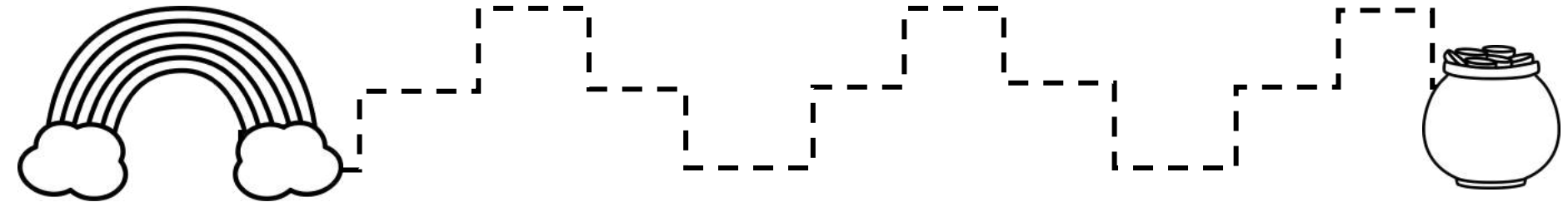
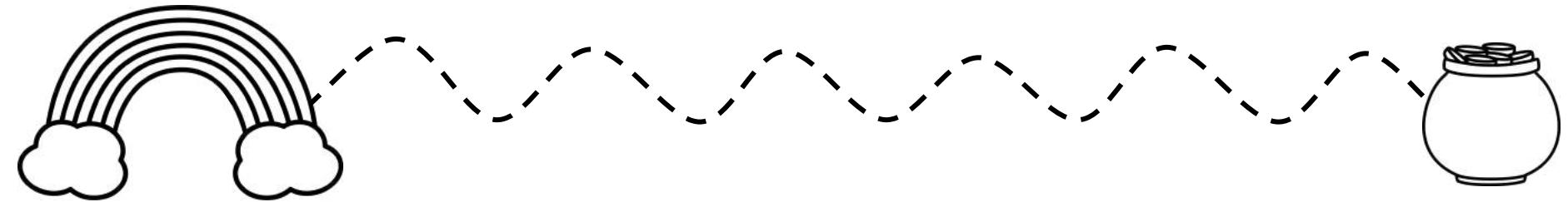
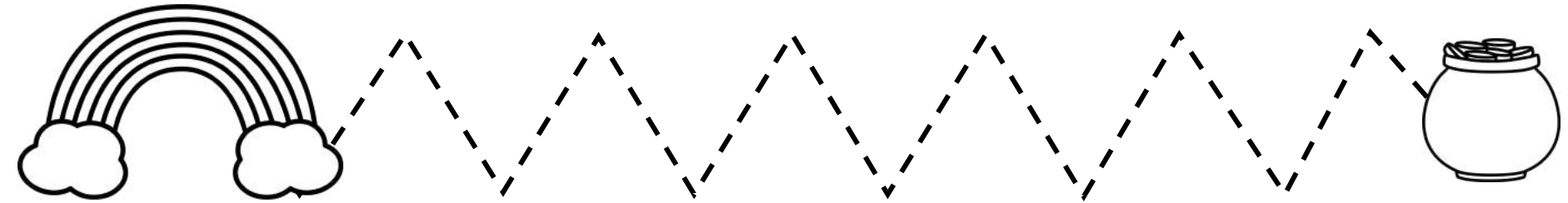
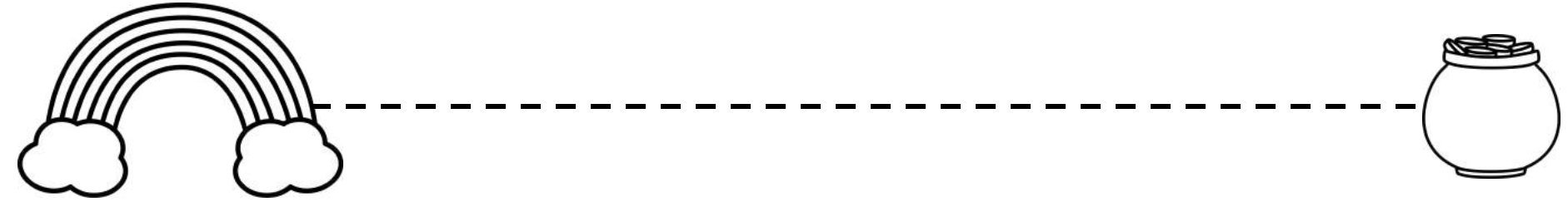

Name _____

Trace the line from left to right.

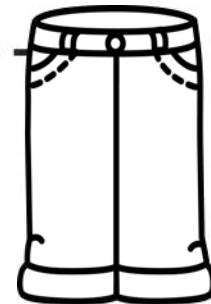
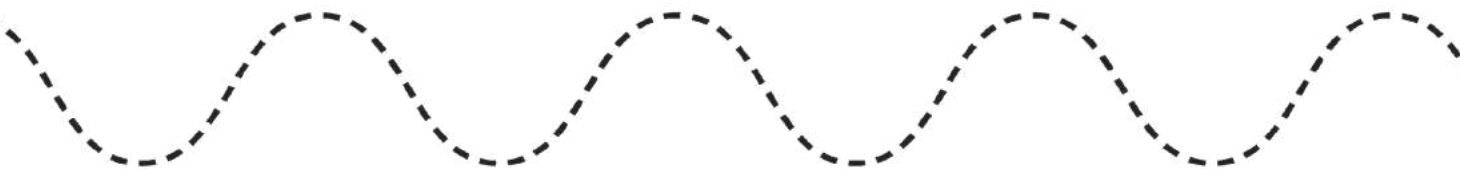
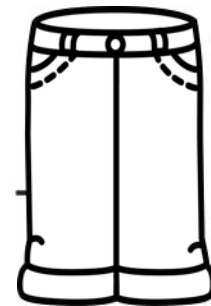

Name _____

Trace the line from left to right.

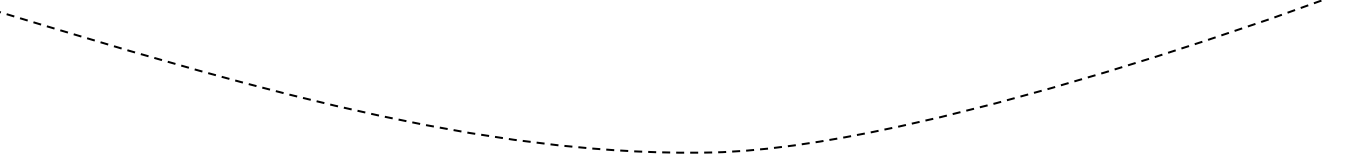
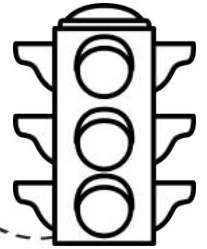

Name _____

Trace the line from left to right.

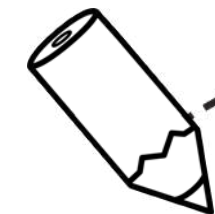
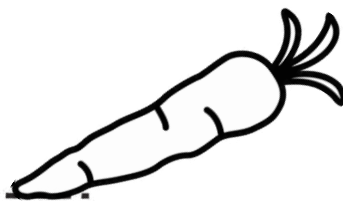
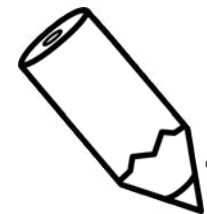
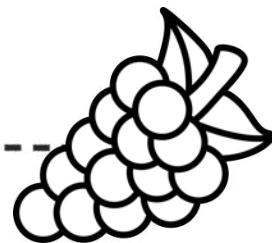
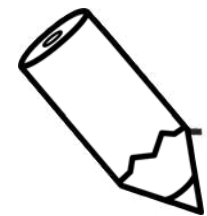
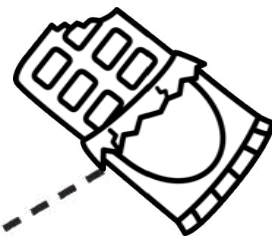
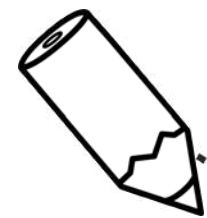

Name _____

Trace the line from left to right.

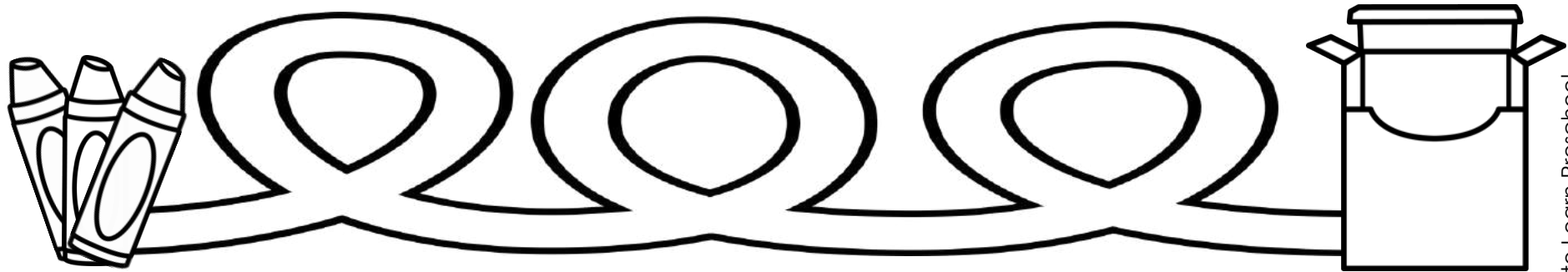
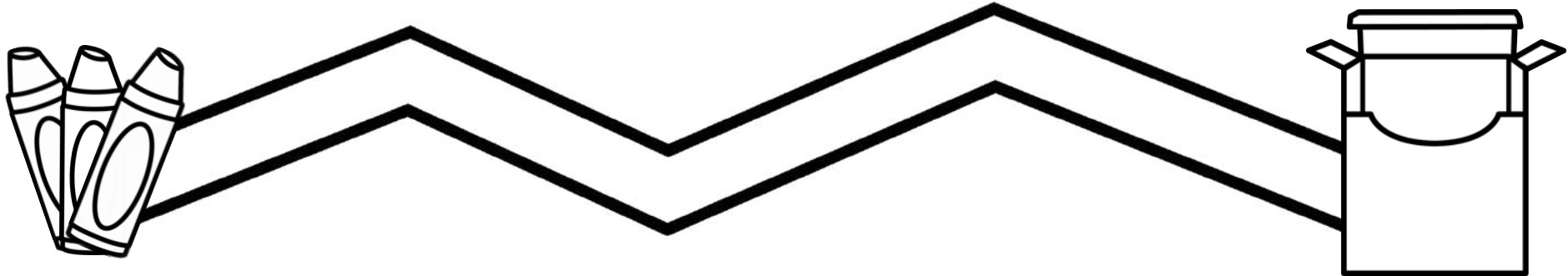
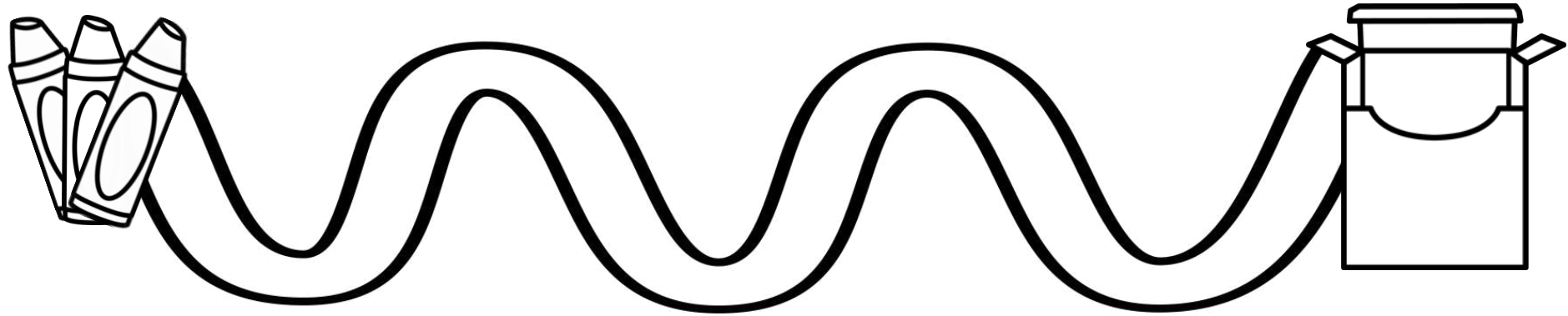

Rhyming Rainbows

Objective: The students identify rhyming words.

Preparation: Copy each puzzle, laminate and cut apart.

Procedure: Students say the name of the picture on the left side of the rainbow and find the rhyming picture on the right side of the rainbow.

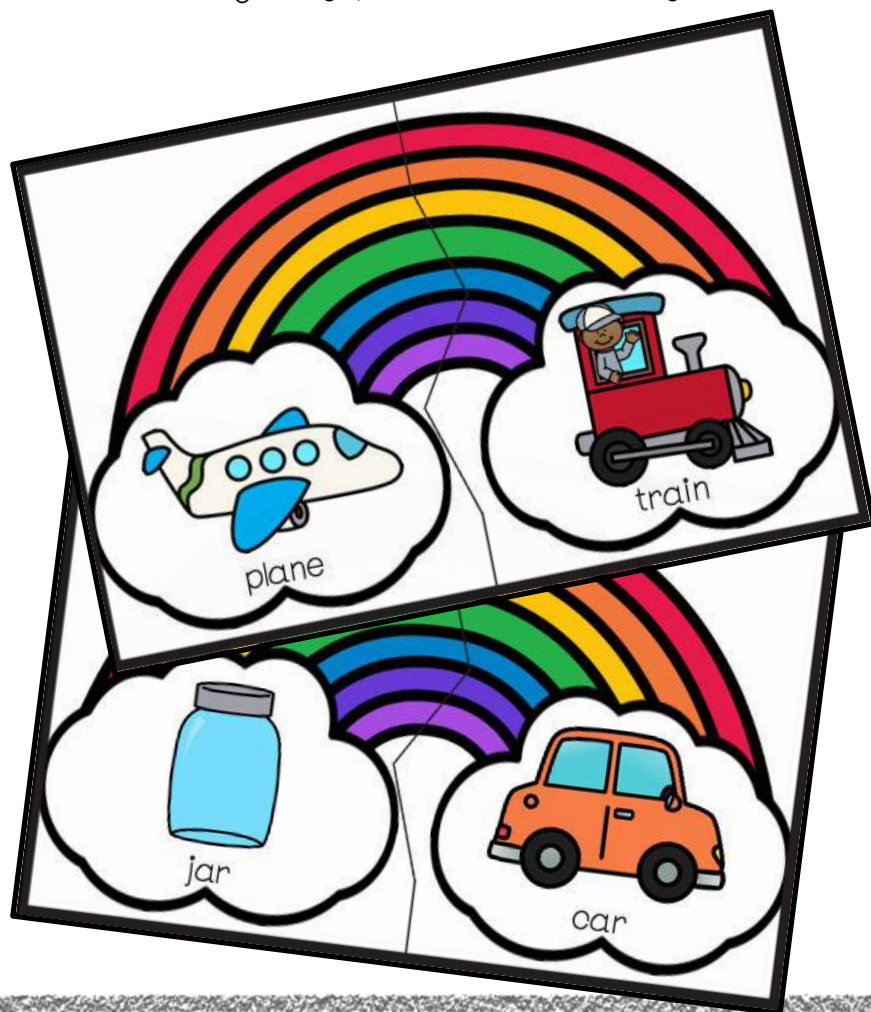

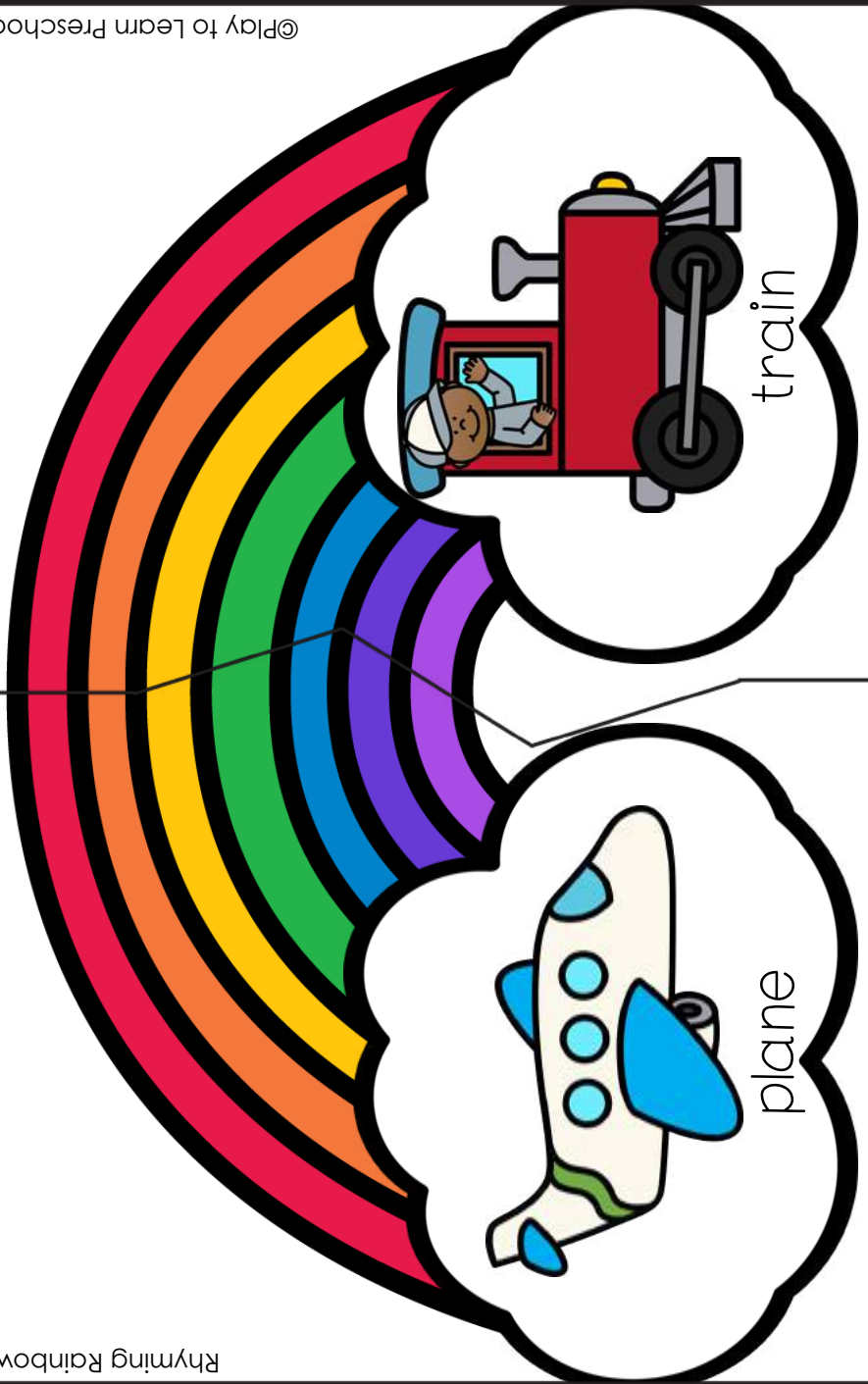
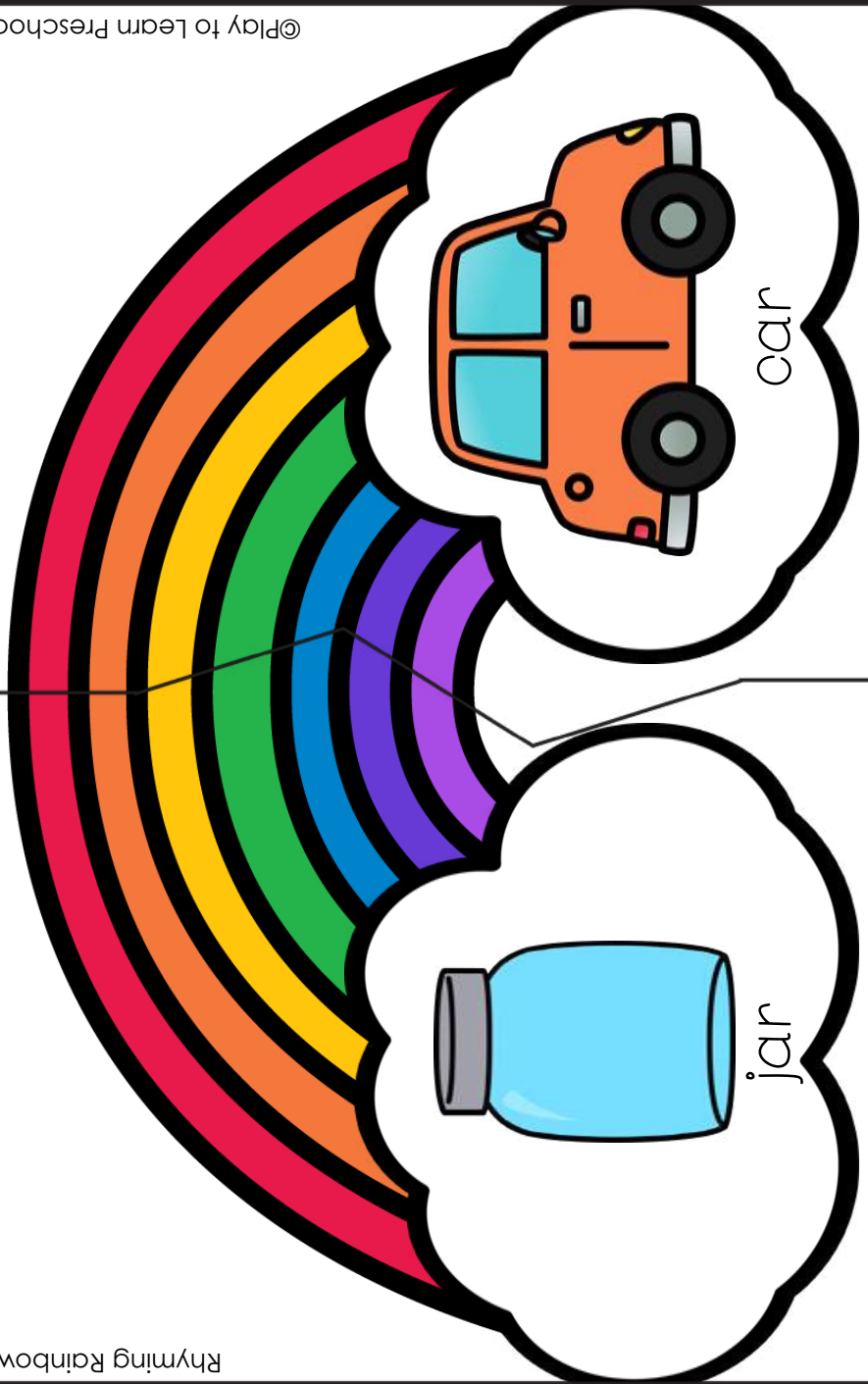



boat



goat

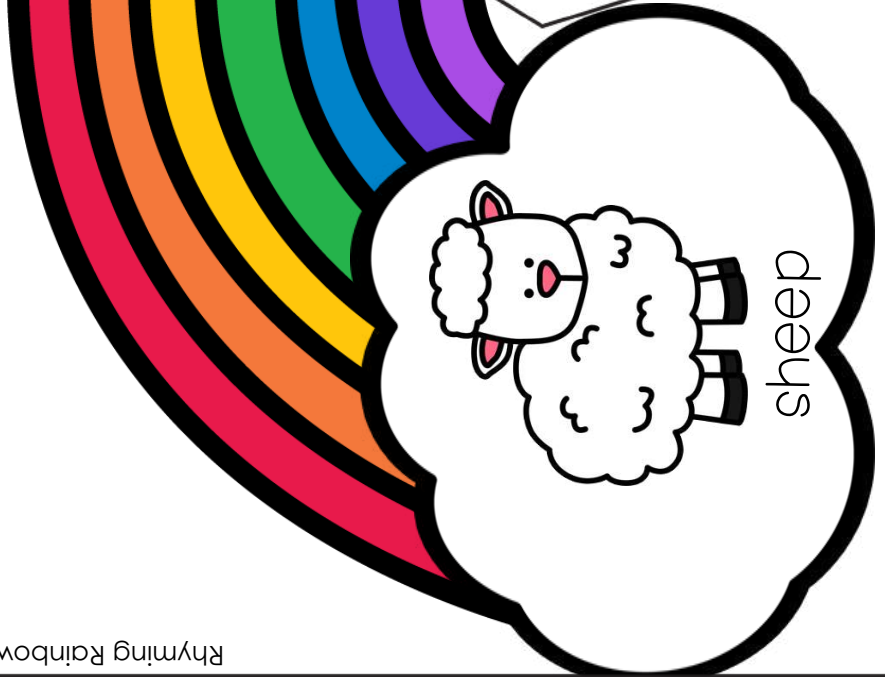

sheep



jeep

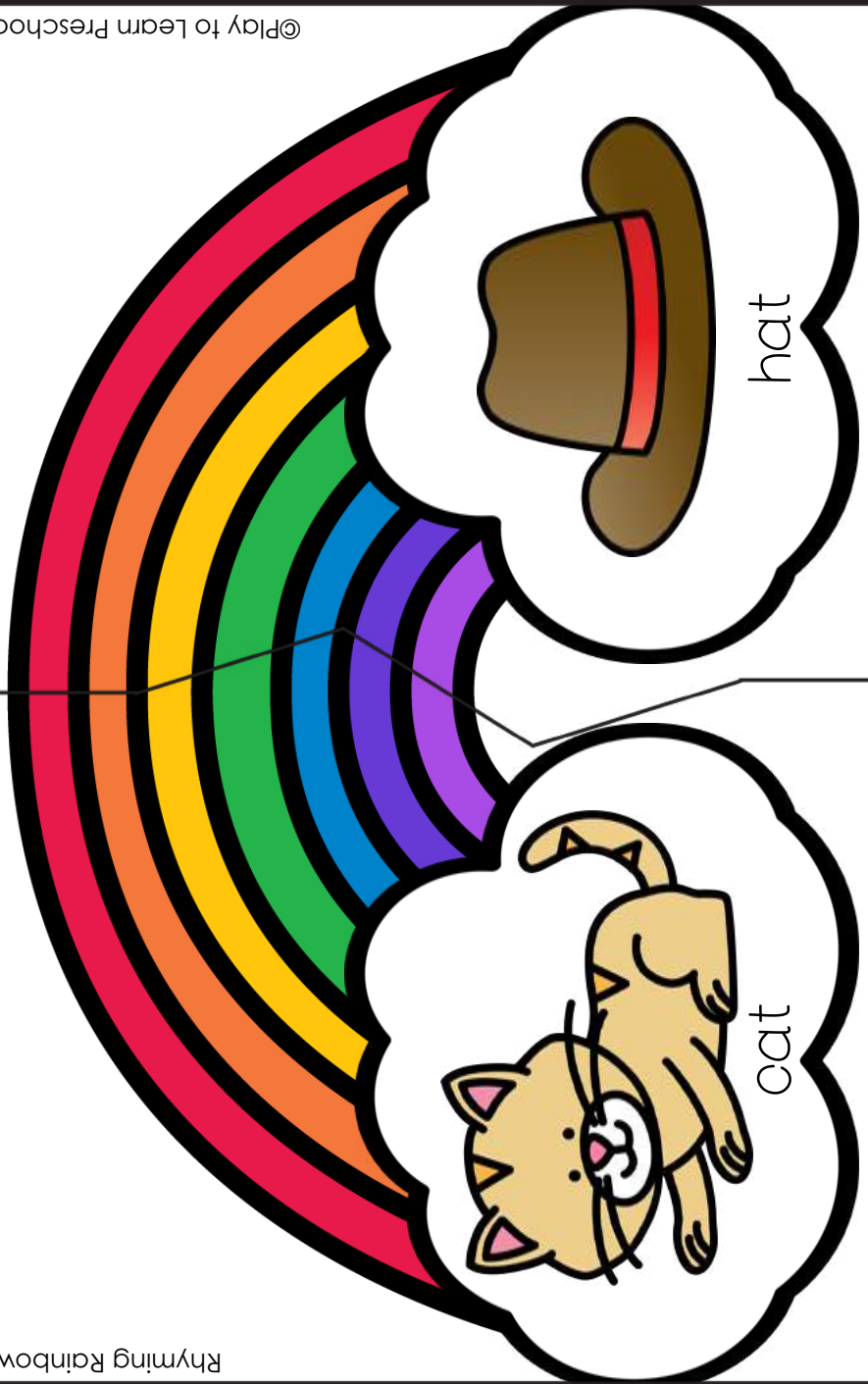

cat

hat

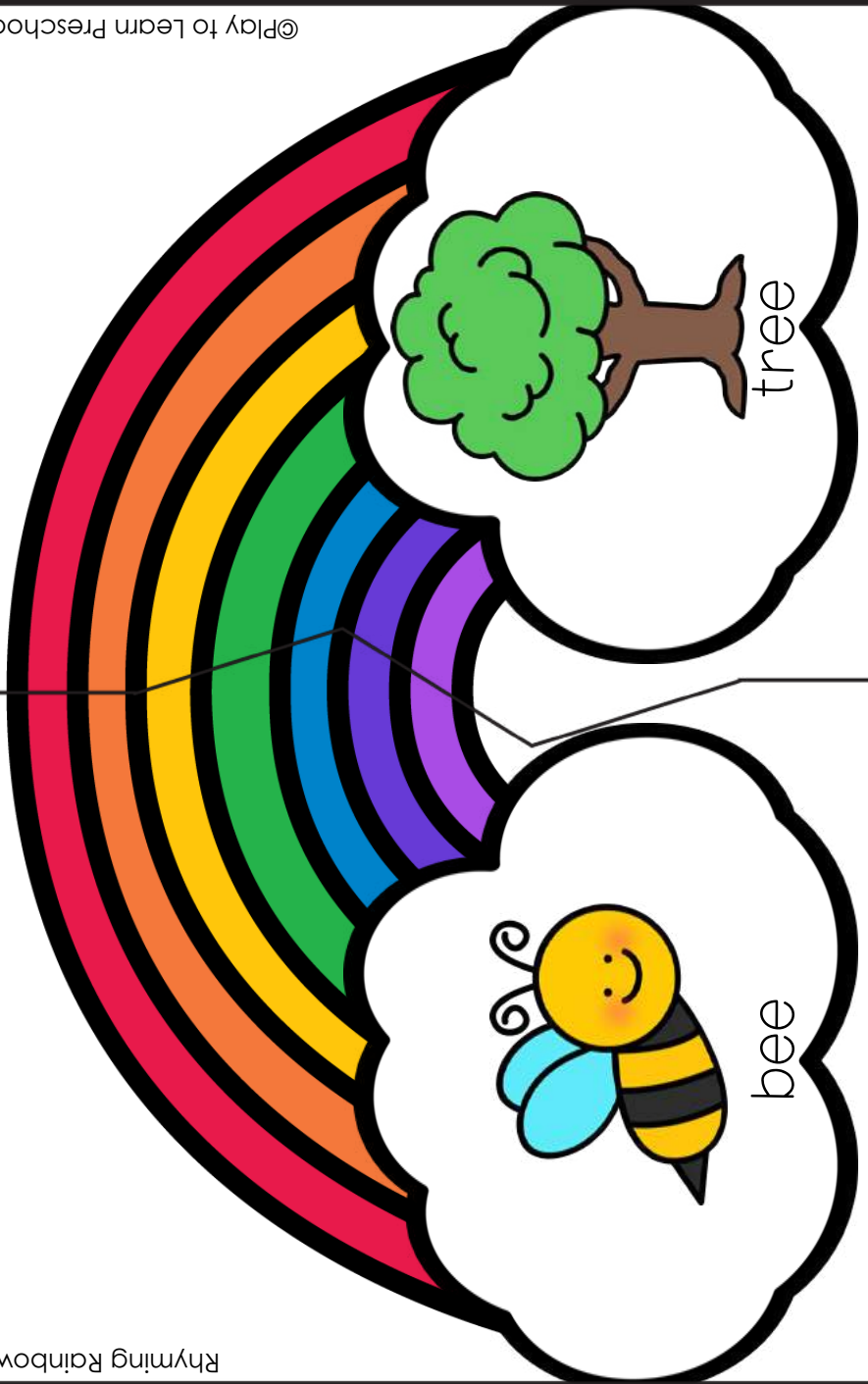

bee

tree

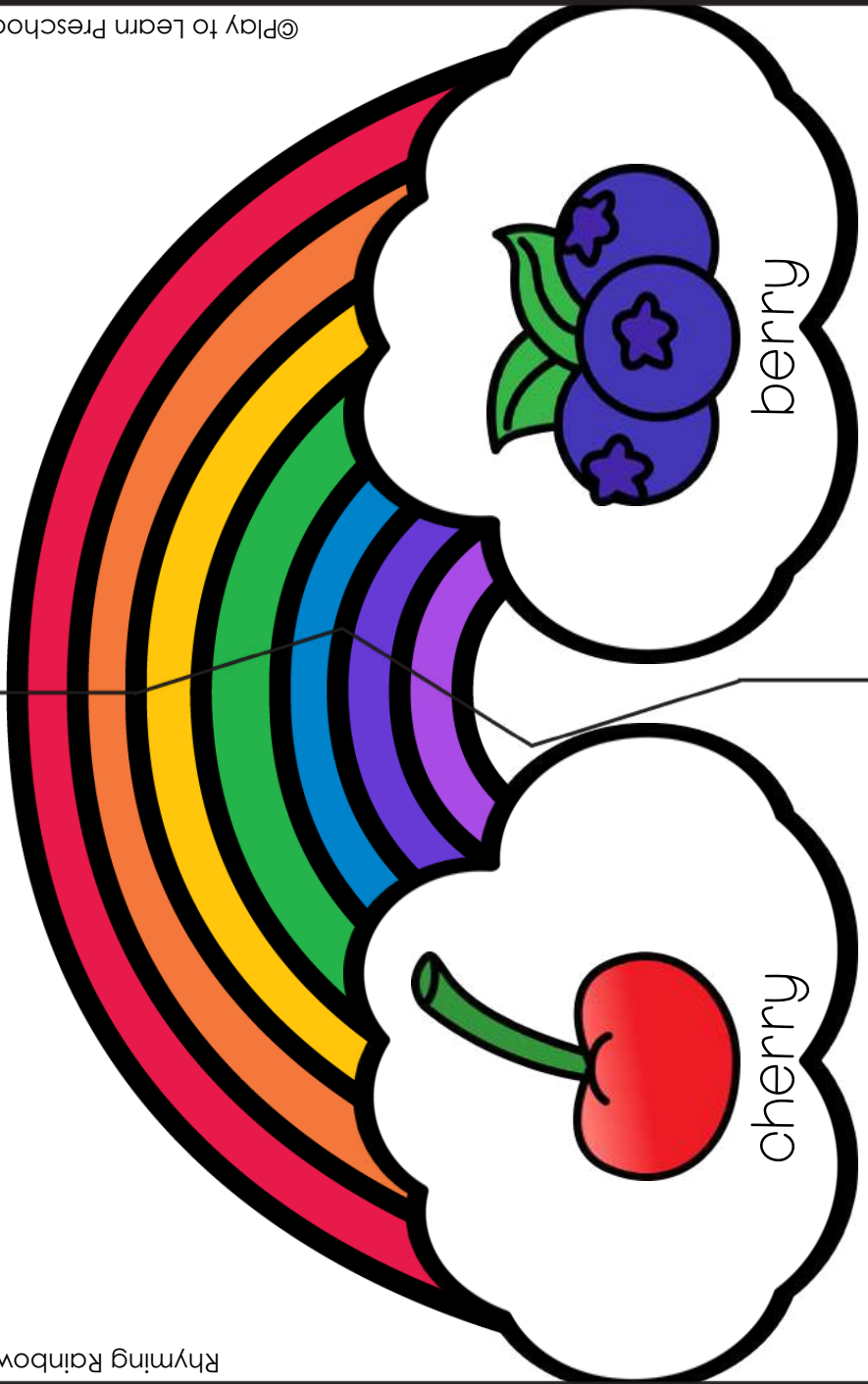
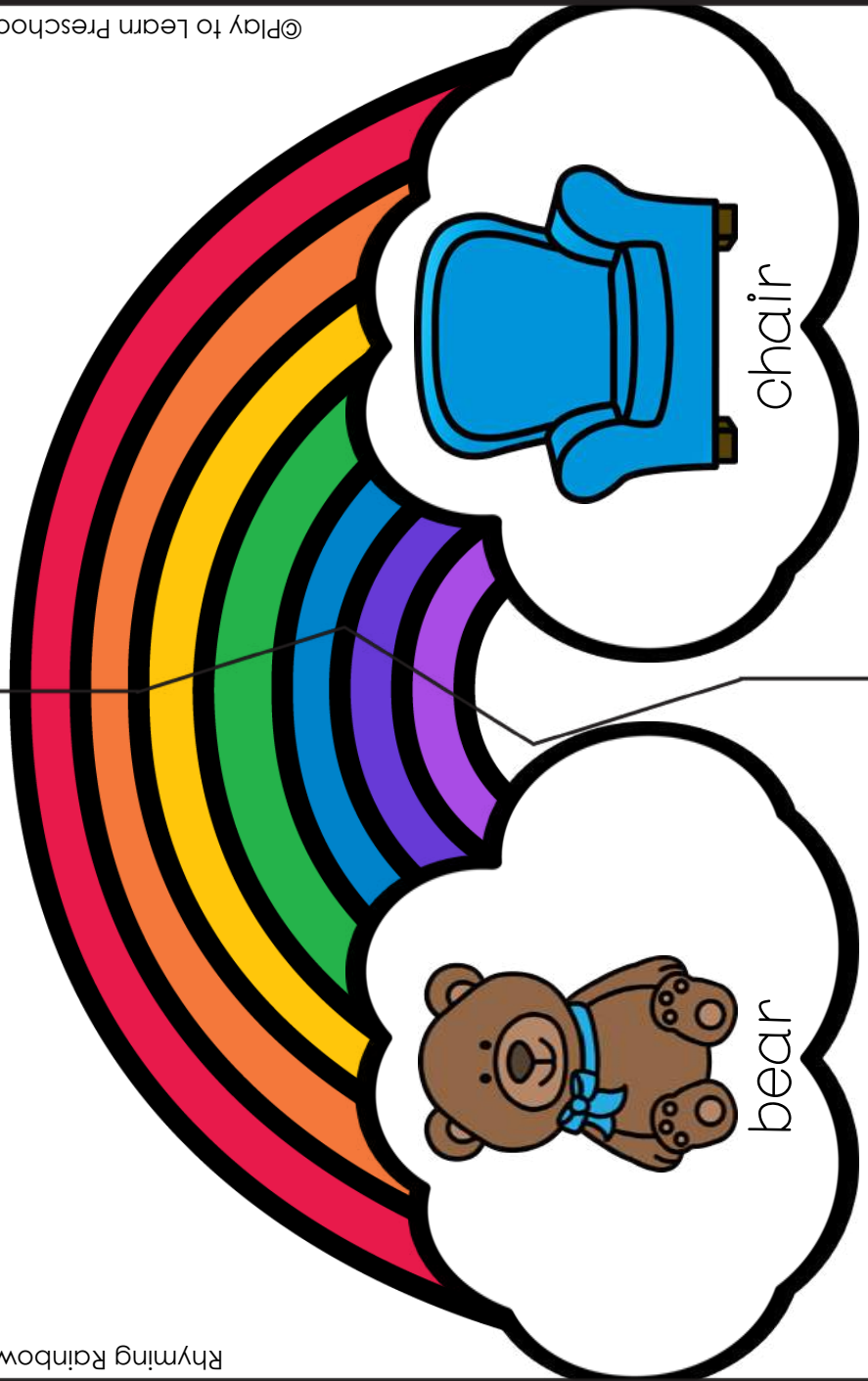

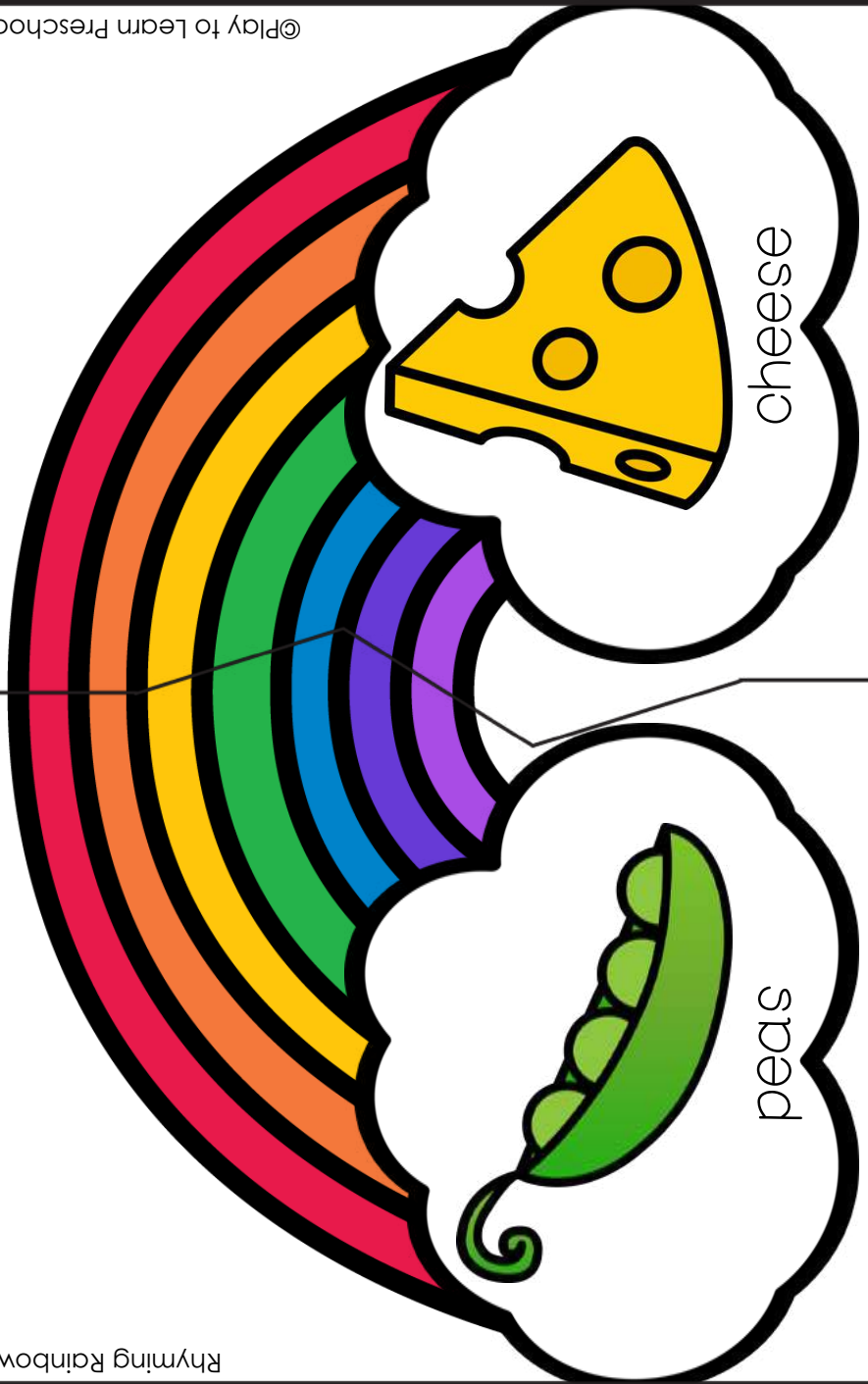

peas

cheese

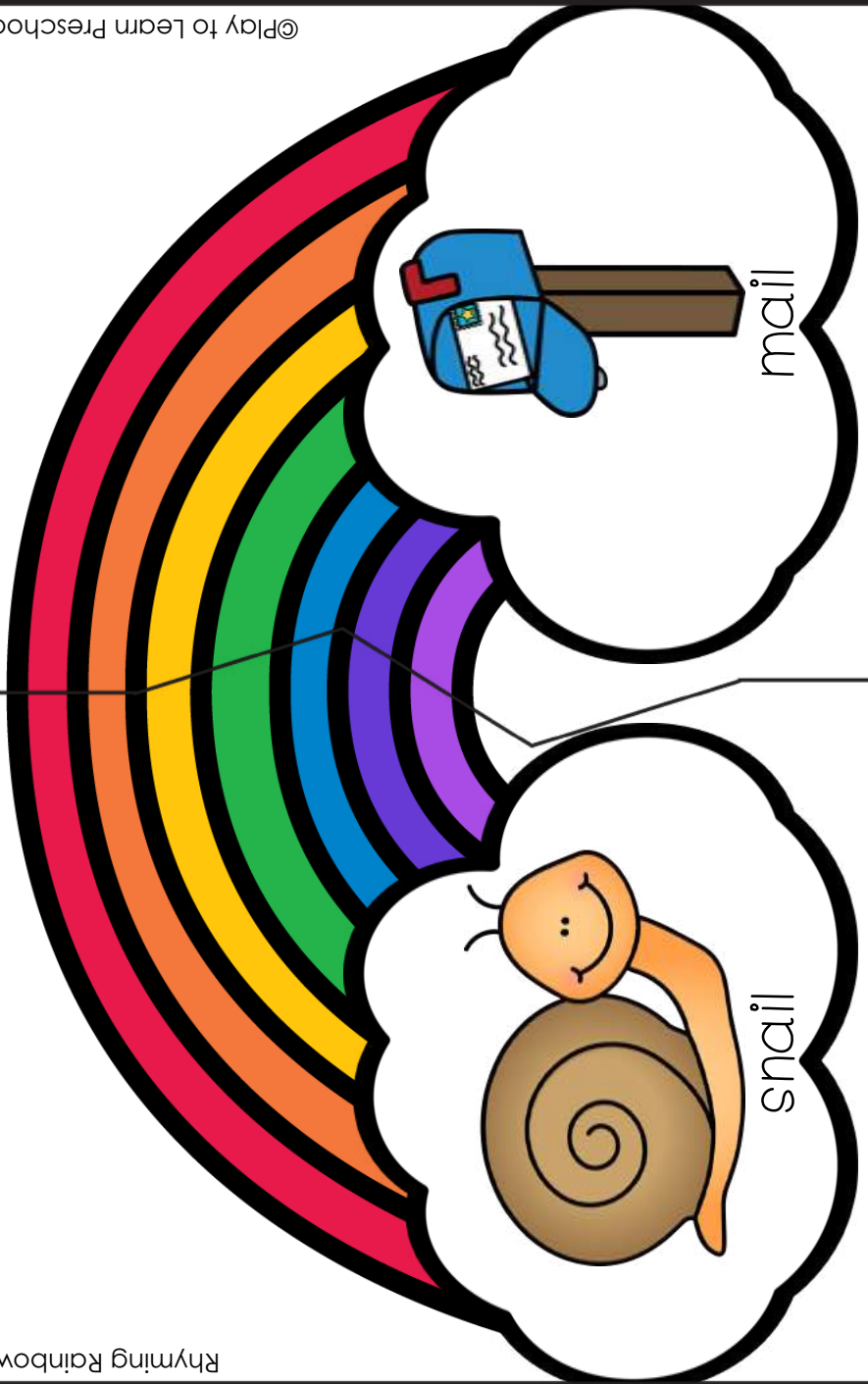

snail

mail

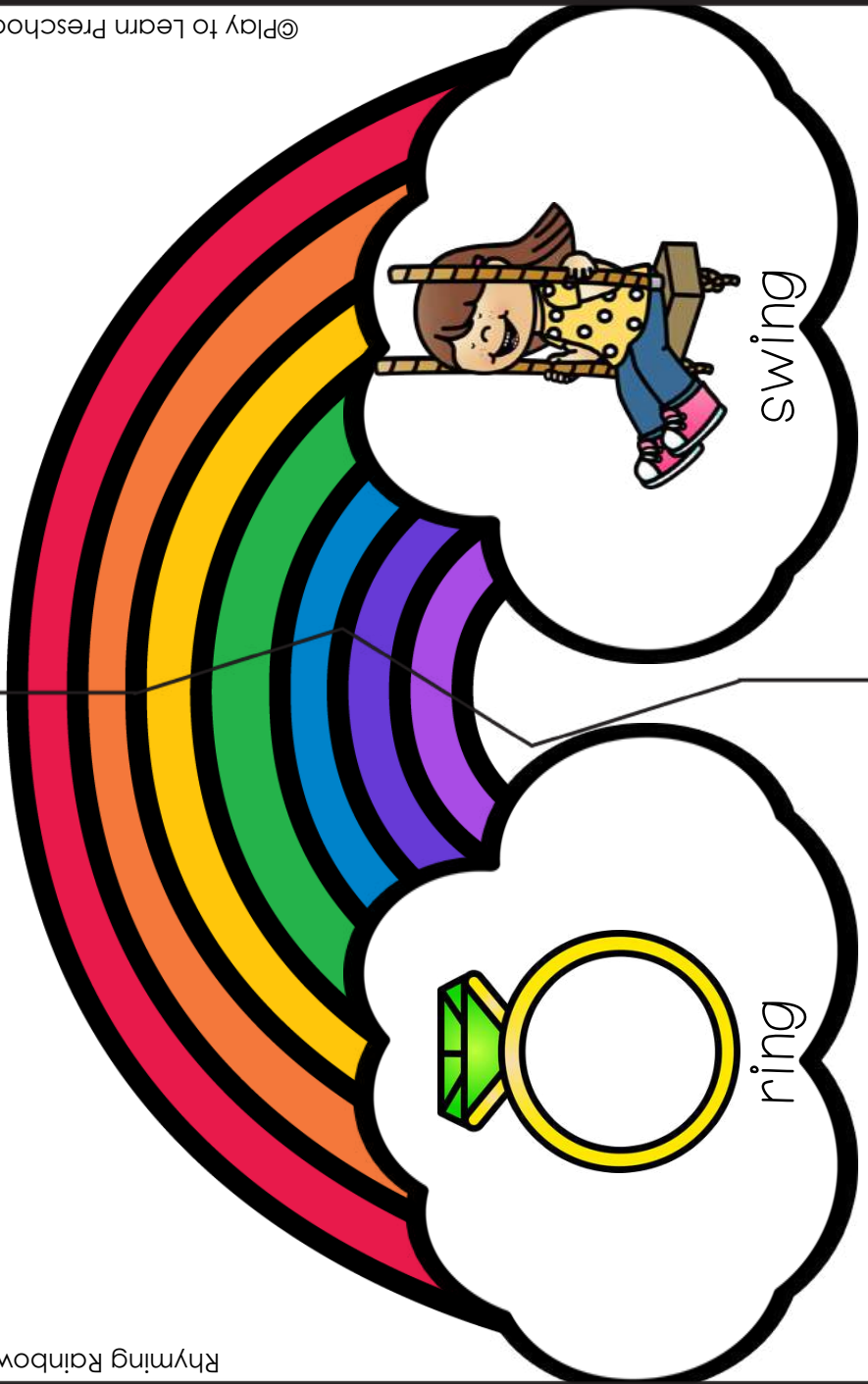
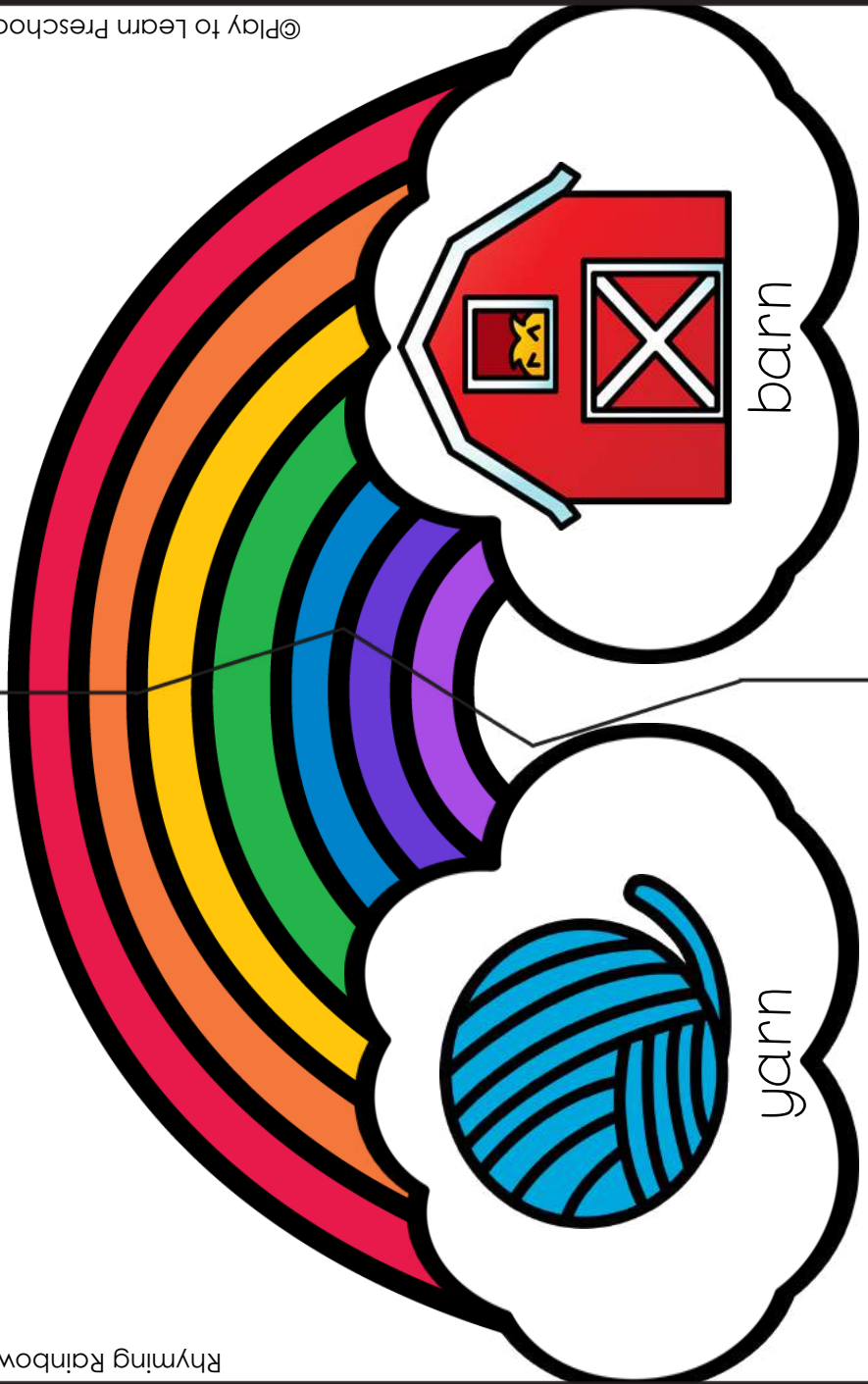



hug

hug

©Play to Learn Preschool

This page features a large, colorful rainbow. Two thought bubbles are connected to the rainbow by lines. The left thought bubble shows a girl in a yellow shirt hugging a boy in an orange shirt. The right thought bubble shows a purple rug with fringed edges.

fox

box

©Play to Learn Preschool

This page features a large, colorful rainbow. Two thought bubbles are connected to the rainbow by lines. The left thought bubble shows a cartoon fox with a white chest patch. The right thought bubble shows a brown cardboard box.

Writing Practice

Objectives: The students will write letters.

Preparation: Copy each page and place into a plastic sleeve (or print on cardstock and laminate).

Procedure: Students use a dry erase marker to trace the word.

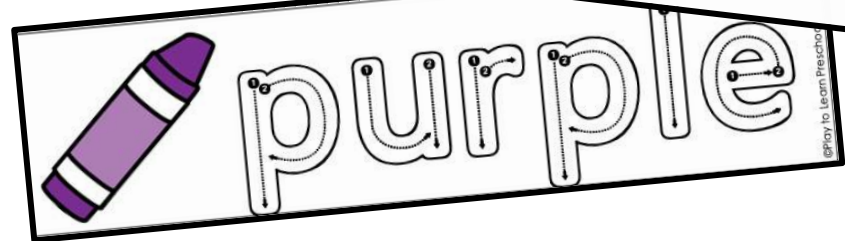
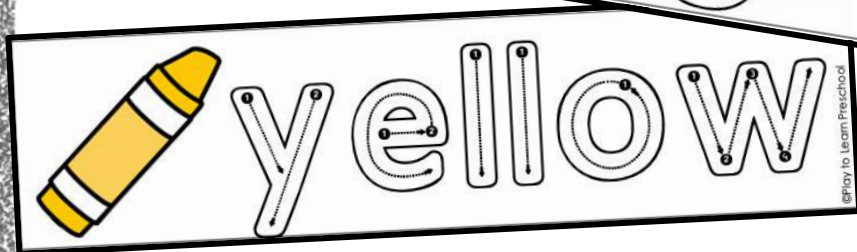
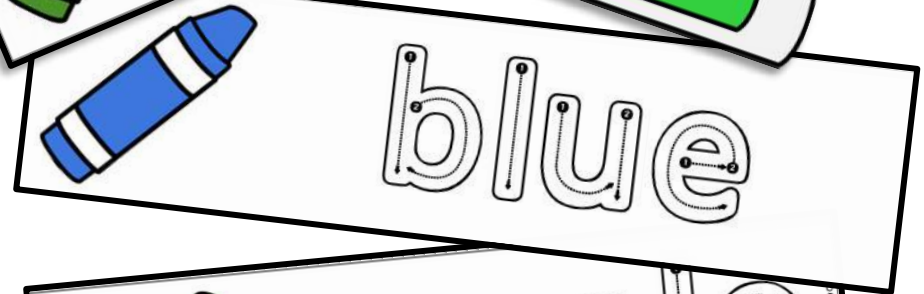
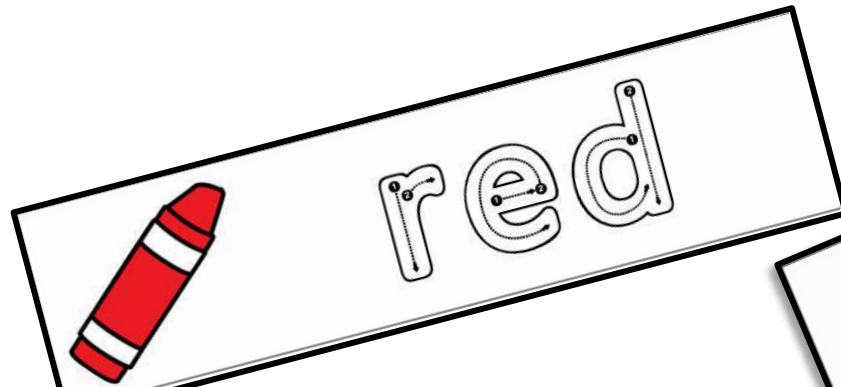

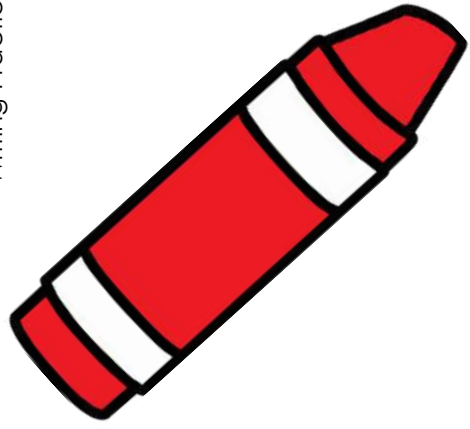

r e e d

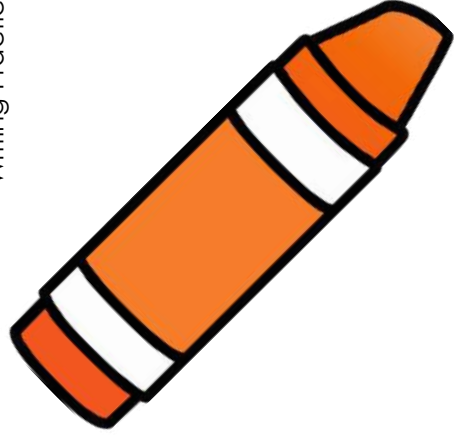

o r a n g e e

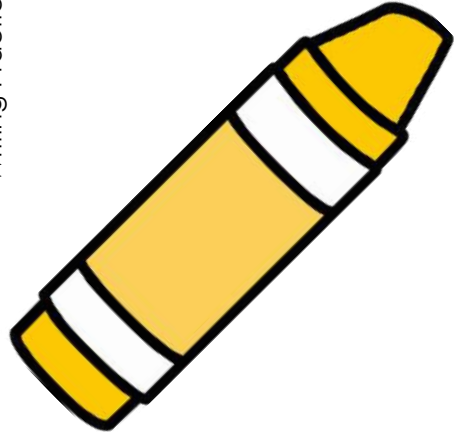

y e l l o w w

Writing Practice

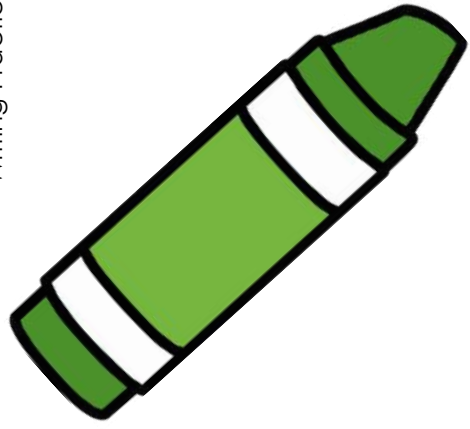

g r e e n

Writing Practice

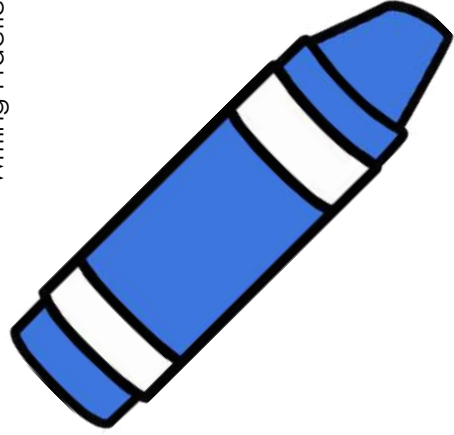

b l u e

Writing Practice

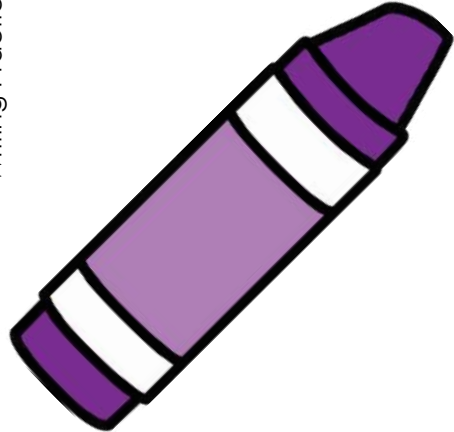

p u r p l e

Writing Practice

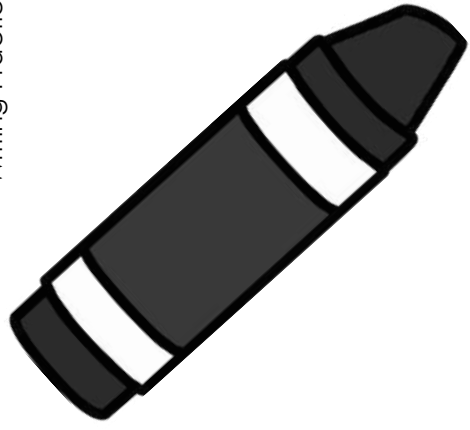

b l a c k

Writing Practice

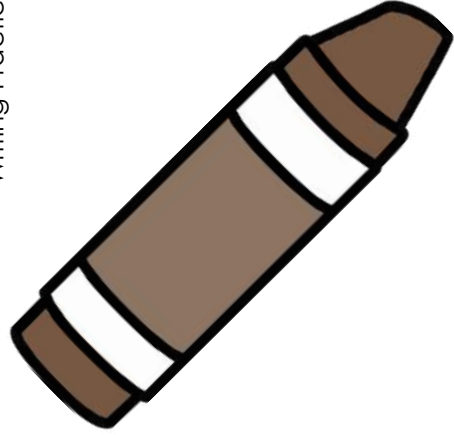

b r o w n

Writing Practice

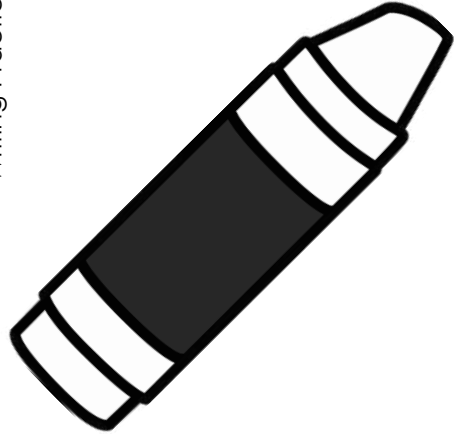

w h i t e

Writing Practice

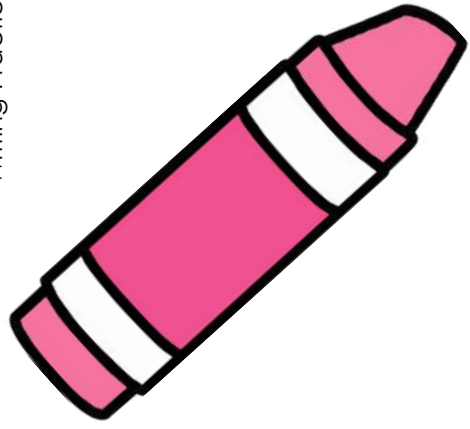

p i n k

Writing Practice

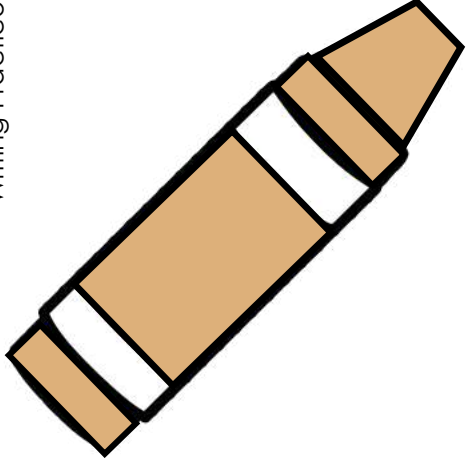

t a n

Writing Practice

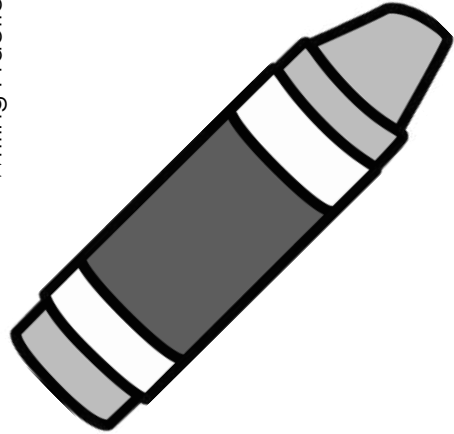

g r a y

Journaling

Objective: The students will understand the purpose of writing.

Procedure: Print the journal sheets. Students can use the journal prompts to write and draw a picture. The words can also be written for the student if necessary.

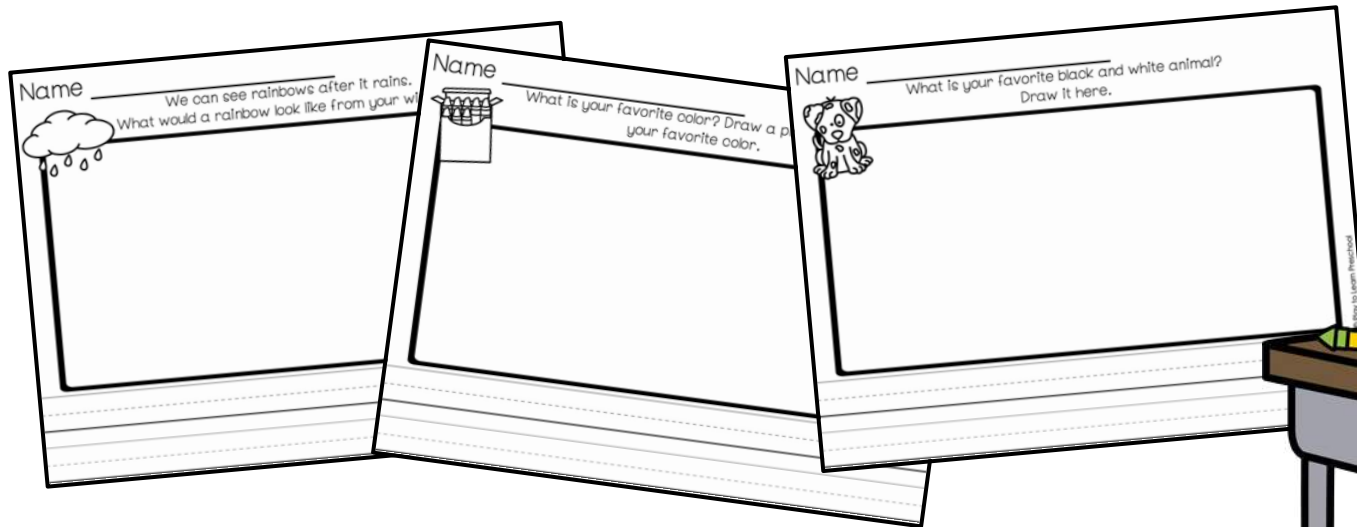

Learning to draw and write is a developmental process. Young children need lots of time and opportunities to scribble, draw, and write. This is called “emergent literacy.” The following is a very *general* guide to how children progress:

Early (ages 3-4)

- Read the prompt to the child and talk about it together.
- Encourage the child to draw a picture. It's okay if it is not yet a recognizable shape or image.
- Ask the child to tell about the picture. “Can you tell me about your picture?”
- Repeat what they say and write down your child's dictation on the lines. Be sure to date it!

Intermediate (ages 4-5)

- Read the prompt to the child and talk about it together.
- Encourage the child to draw a picture.
- Ask the child to tell about the picture. “Can you tell me about your picture?”
- Encourage the child to write about it on the lines. (The child will likely make scribbles or letter-like formations.)
- Ask your child if they want you to write their dictation on the lines as well.

Advanced (ages 5-6)

- Read the prompt to the child and talk about it together.
- Encourage the child to draw a picture and label it.
- Model for your child how to say a word, stretch it out and listen for the sounds that they hear.
- For example, if they draw a bear, say “bear.” Listen for the B sound and write the letter B to match. Can they hear any other sounds? Maybe they can also hear and write the letter R.
- Children may ask for you to write words for them to copy on the lines. This is fine as long as you also encourage them to write the letters and sounds that they hear.

Name _____

We can see rainbows after it rains.

What would a rainbow look like from your window?



A large, empty rectangular box with a thick black border, intended for drawing a rainbow.

Name _____

What is your favorite color? Draw a picture using
your favorite color.

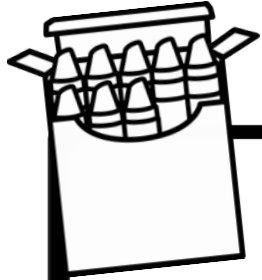

A large, empty rectangular box with a thick black border, intended for drawing a picture related to the question above.

Name _____

What is your favorite black and white animal?
Draw it here.



A large, empty rectangular box with a thick black border, intended for drawing a black and white animal.

Name _____

Chameleons can be different colors. Draw a chameleon below using many colors and then write the colors you used on the lines below.

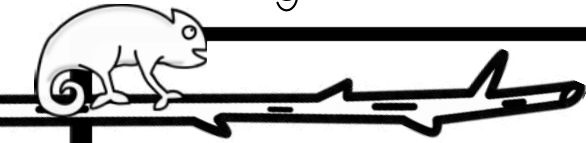

A large, empty rectangular box with a thick black border, intended for drawing a chameleon.

Two sets of horizontal lines for writing. Each set consists of a solid top line, a dashed middle line, and a solid bottom line.

Counting

File Folder Game

Objective: The students will count and recognize numbers.

Preparation: Copy the picture cards. Glue the large pictures (first 2 pages) inside a file folder. Cut and laminate the smaller pictures.

Procedure: Students will count and choose the correct number.

Counting

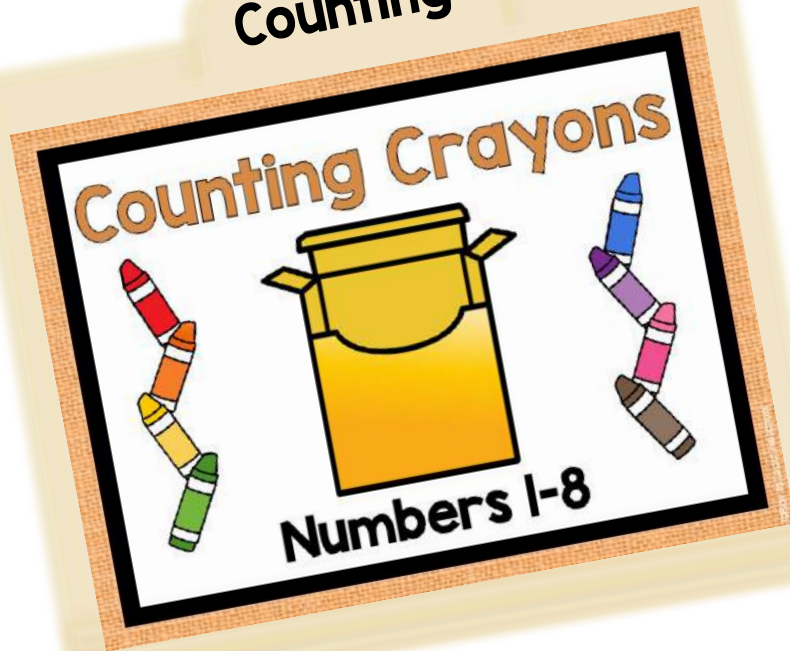

Counting



Counting Crayons

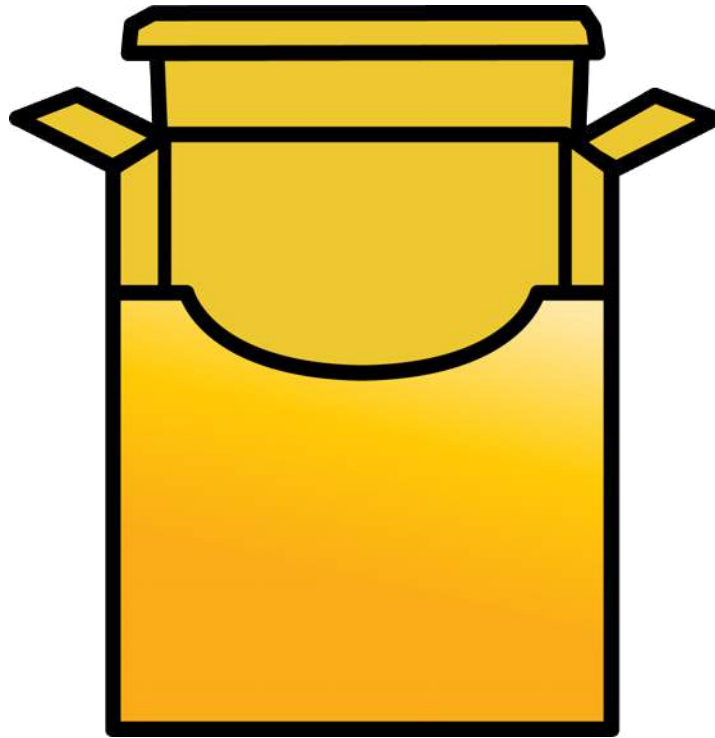
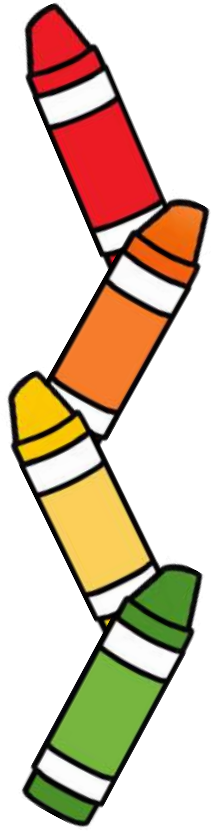

Numbers 1-8



one

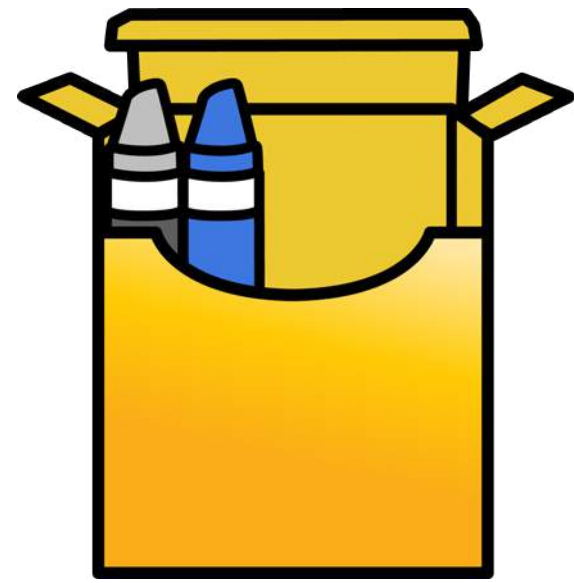

two

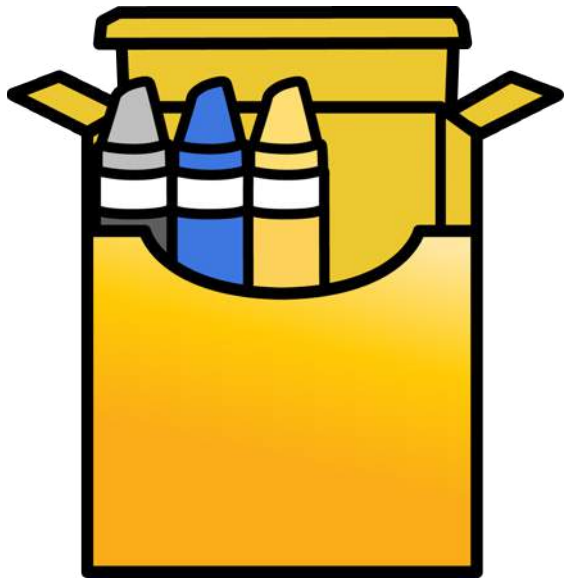

three

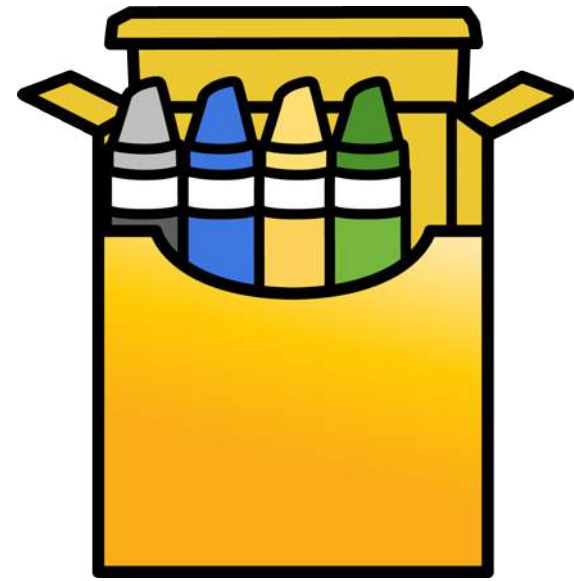

four

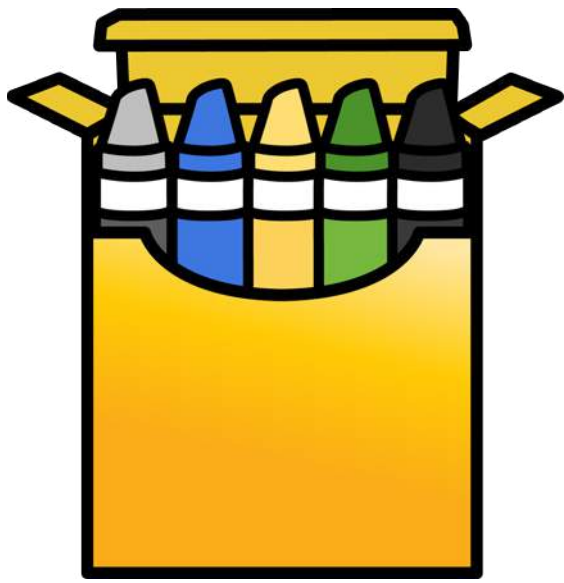

five

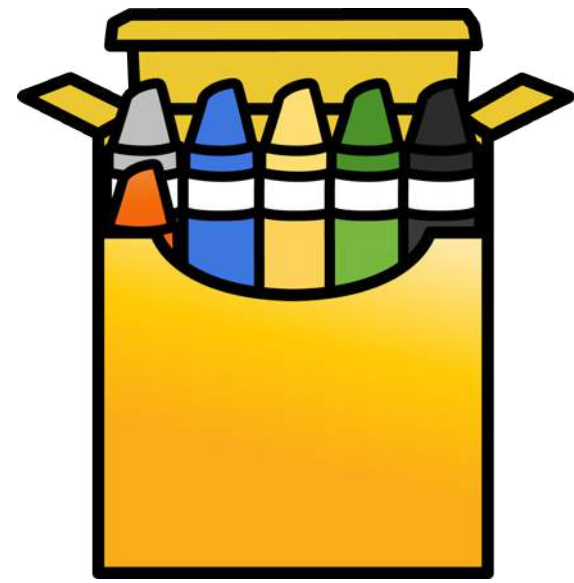

six

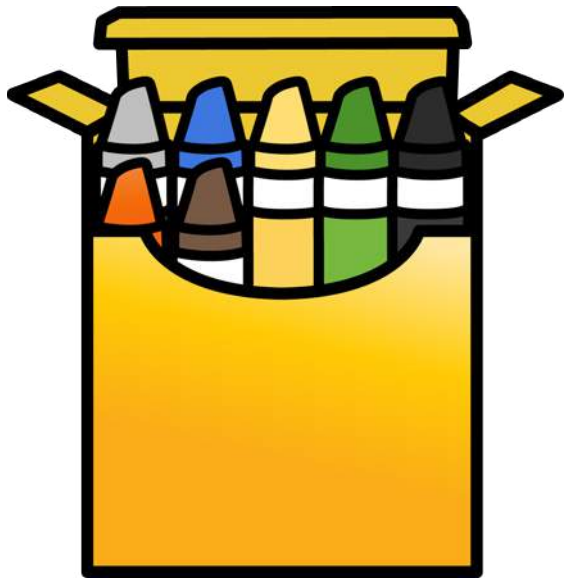

seven



eight

Counting Crayons

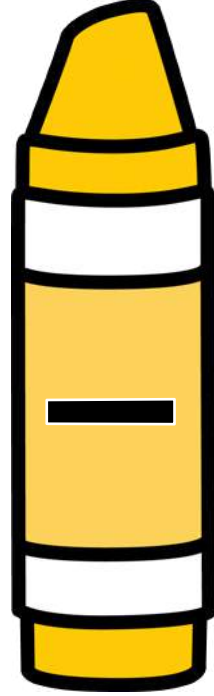

Counting Crayons



Counting Crayons



Counting Crayons



Counting Crayons



Counting Crayons

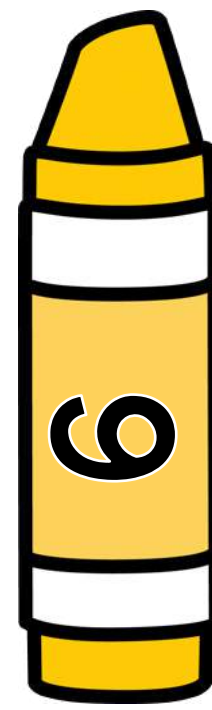

Counting Crayons



Counting Crayons

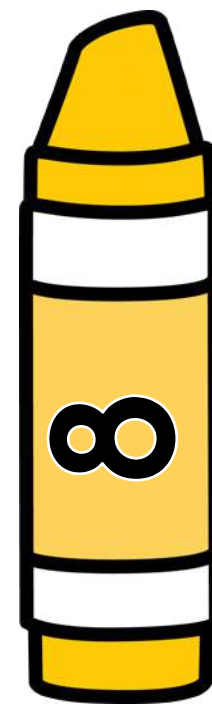

Beginning Sound Sort

Literacy
Center

File Folder Game

Objectives: The students will identify the beginning sound of each word.

Preparation: Copy the picture cards. Glue the cover on the front of the file folder and the sorting mats on the inside. Cut and laminate the smaller pieces.

Procedure: Students sort the pictures by their beginning sound.

Beginning Sound Sort

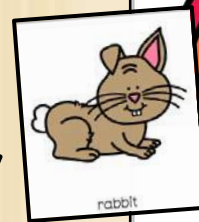
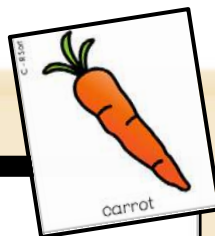
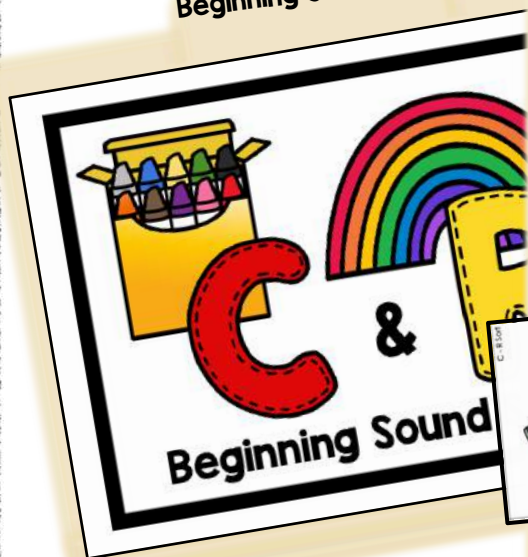

Beginning Sound Sort

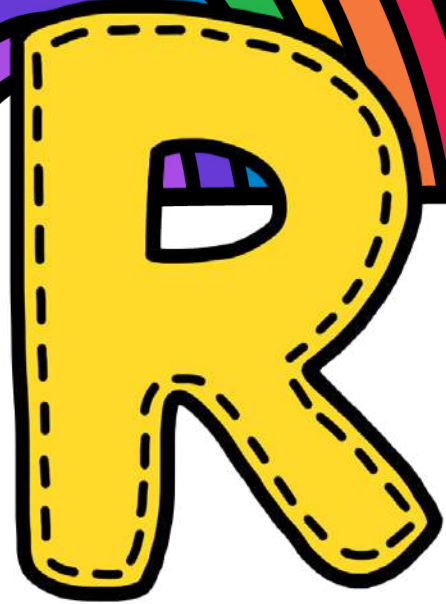
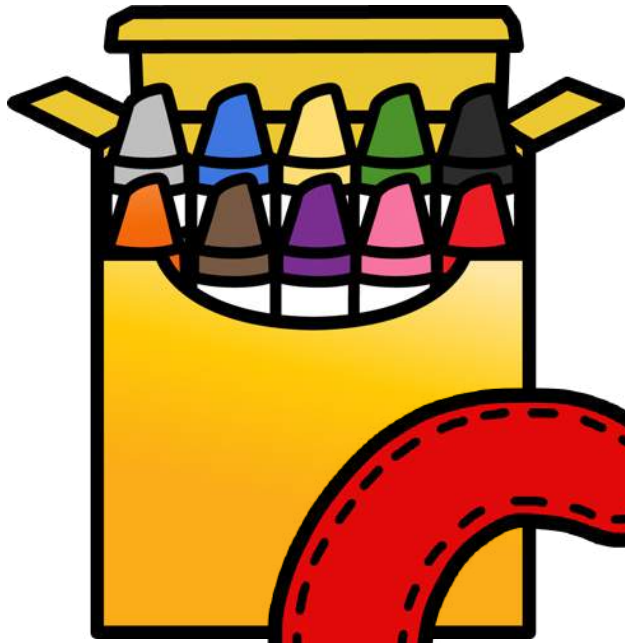

Beginning Sound Sort

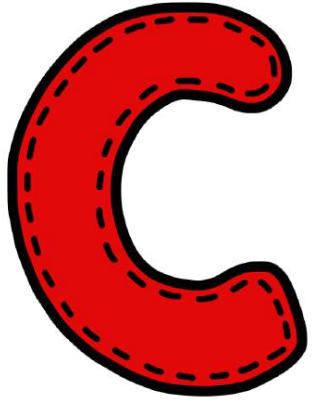

is for

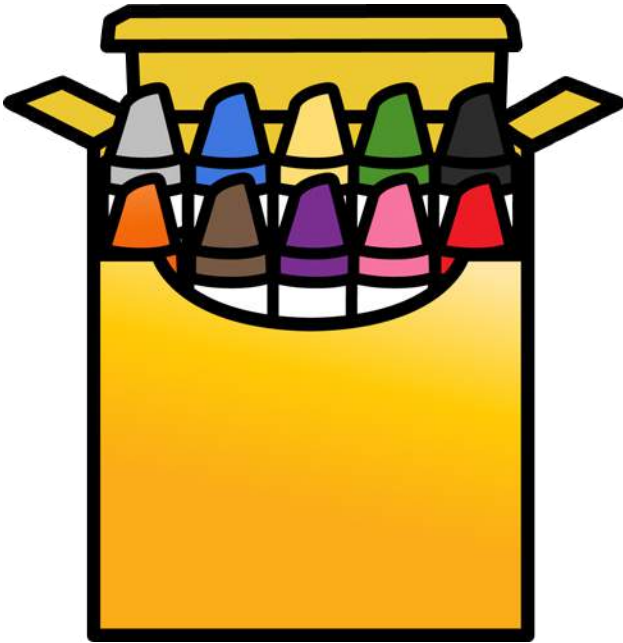

color

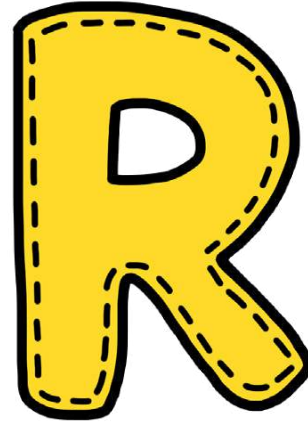

is for

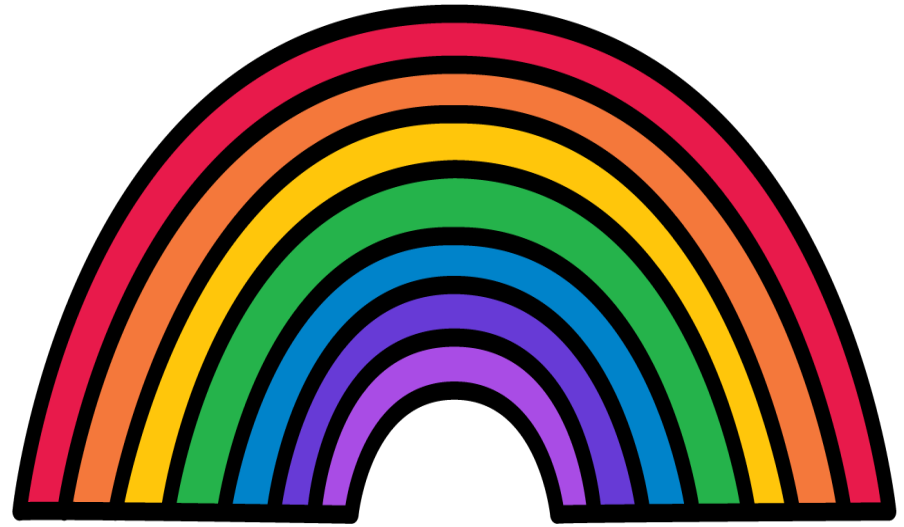

rainbow

C - R Sort



car

C - R Sort

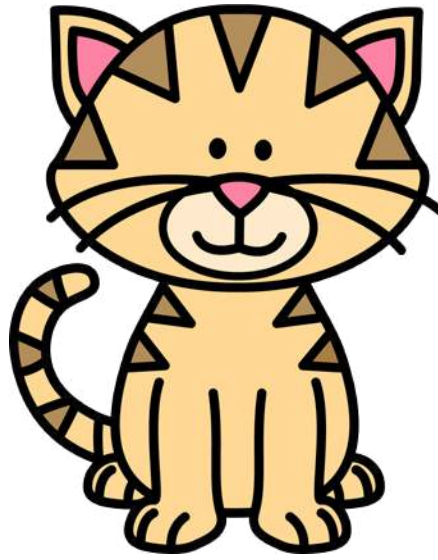

cat

C - R Sort

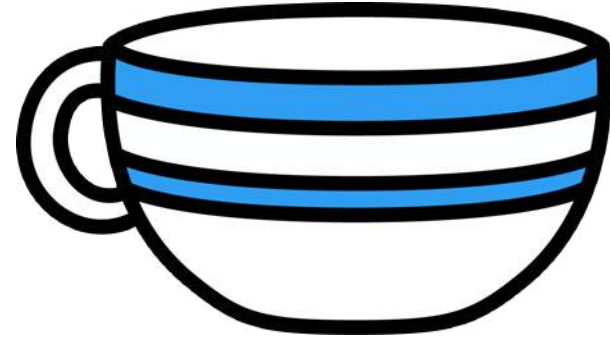

cup

C - R Sort



cake

C - R Sort

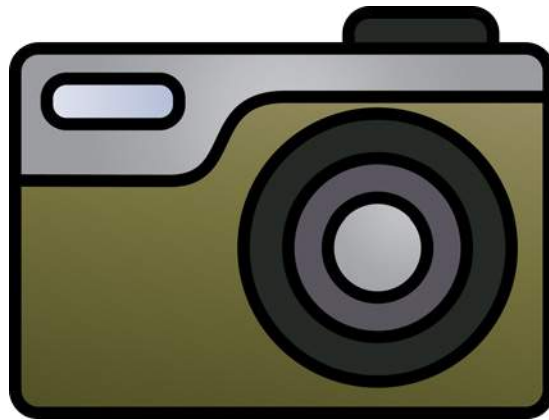

camera

C - R Sort

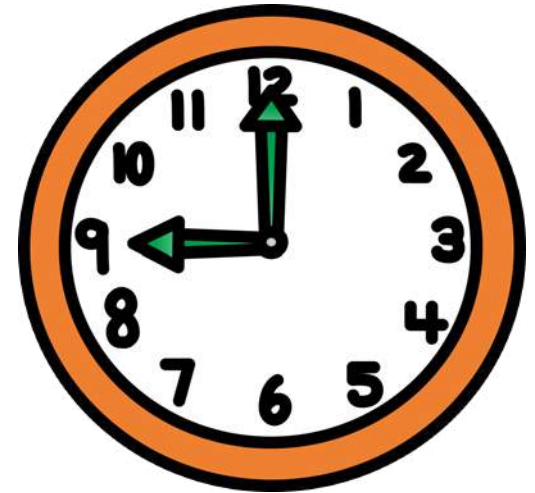

clock

C - R Sort

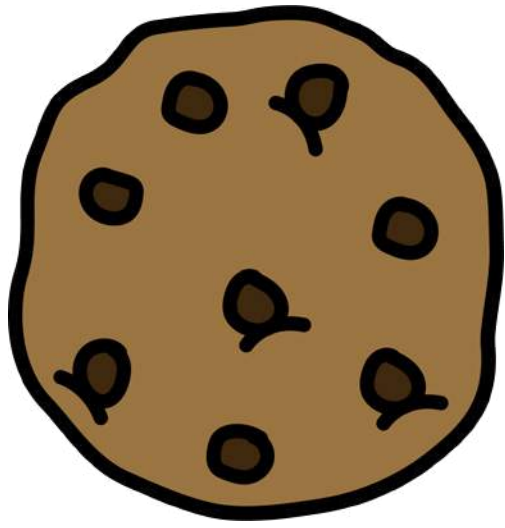

cookie

C - R Sort



cape

C - R Sort

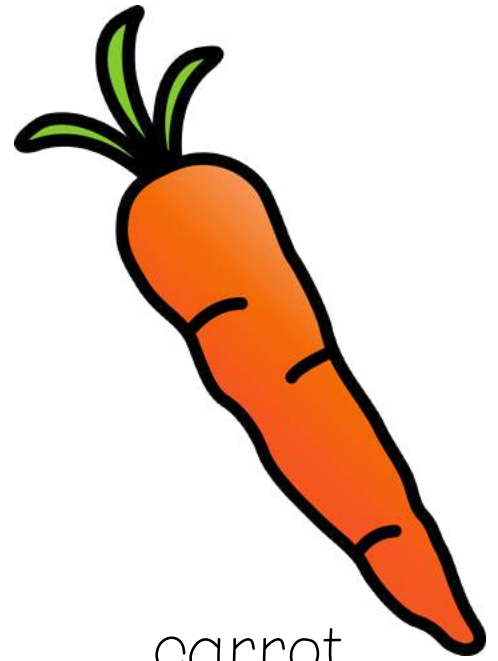

carrot

C - R Sort

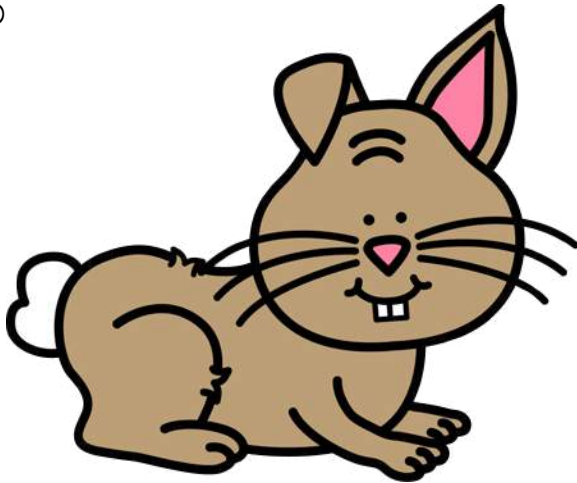

rabbit

C - R Sort



rainbow

C - R Sort



raccoon

C - R Sort

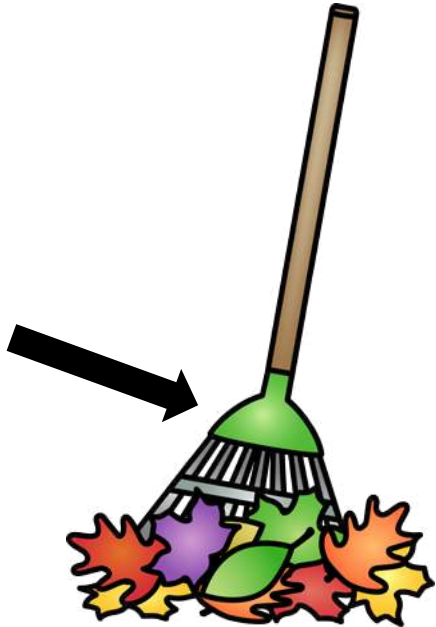

rake

C - R Sort

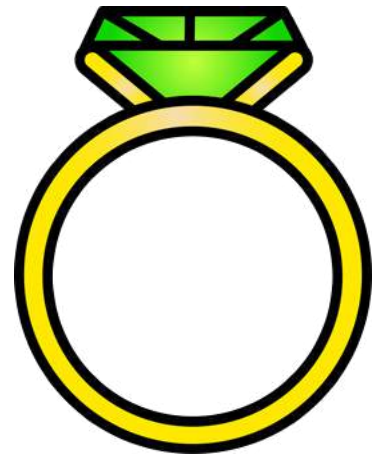

ring

C - R Sort



rain

C - R Sort

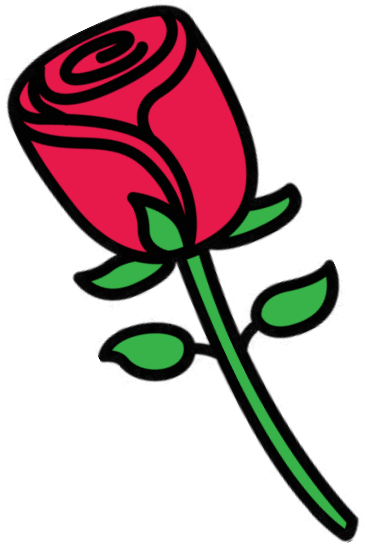

rose

C - R Sort

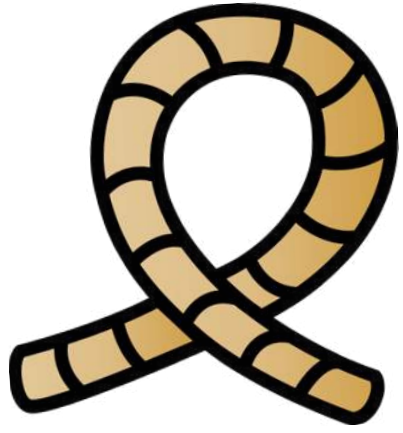

rope

C - R Sort



run

Color Sorting

Objective: The students will sort food pictures by color onto the matching colored plates.

Preparation: Print the colored plates or use the black and white plate to copy to colored paper. Print, laminate and cut apart the food pictures.

Procedure: Students look at the food and identify its color. They place the foods onto the matching plate.

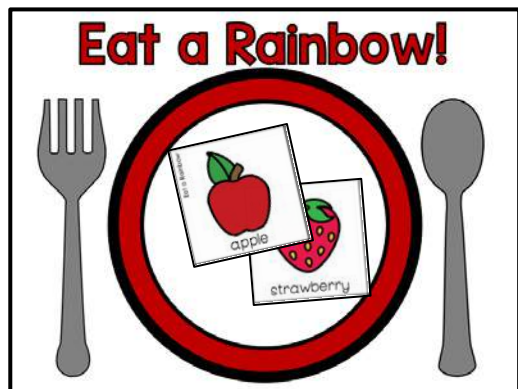

Eat a Rainbow!

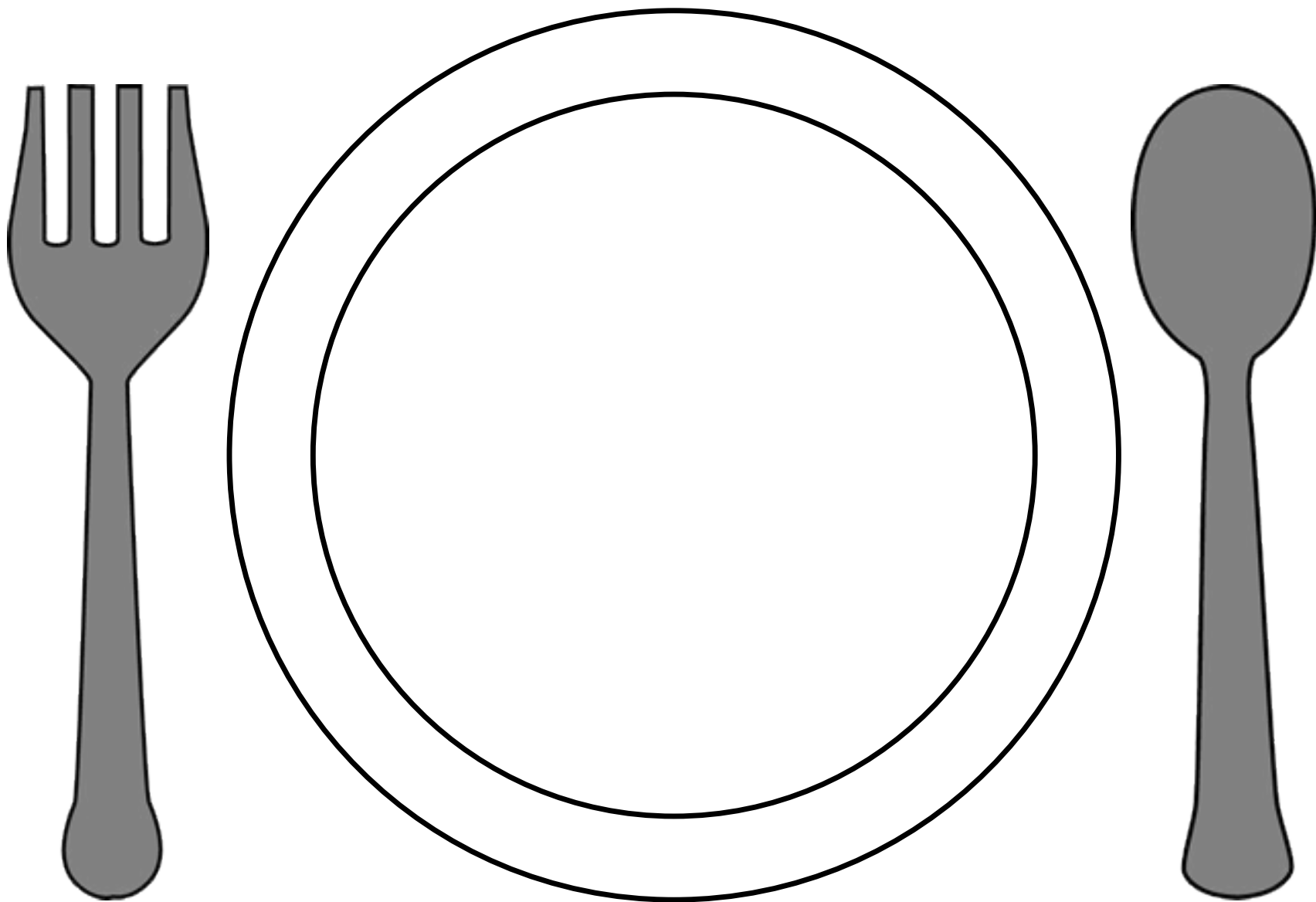

Eat a Rainbow!

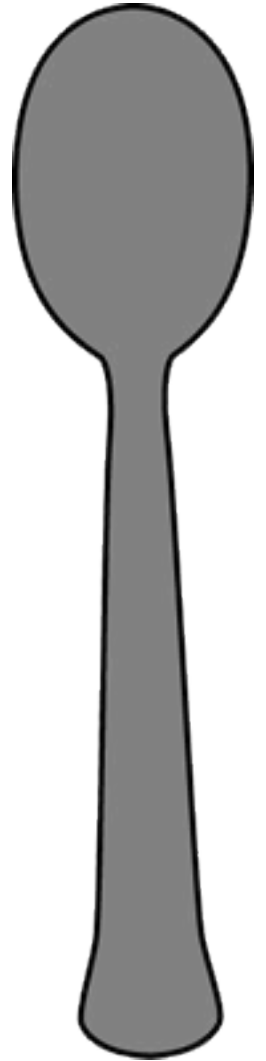
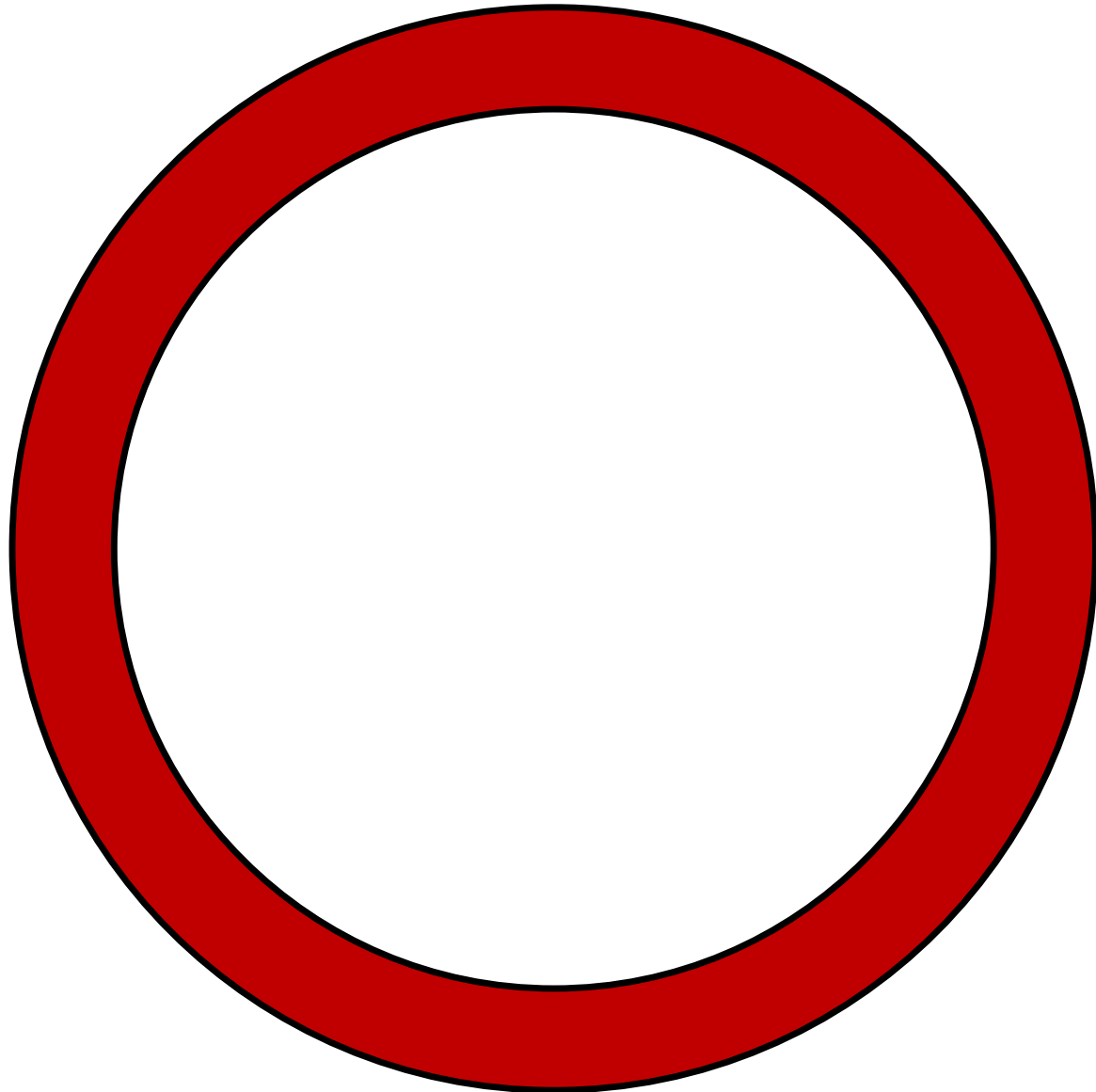
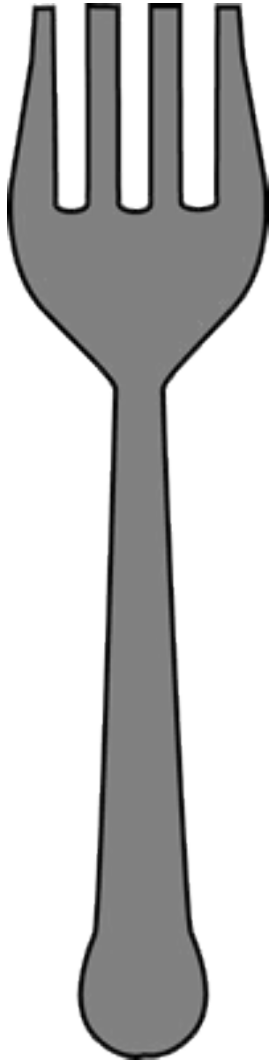

Eat a Rainbow!

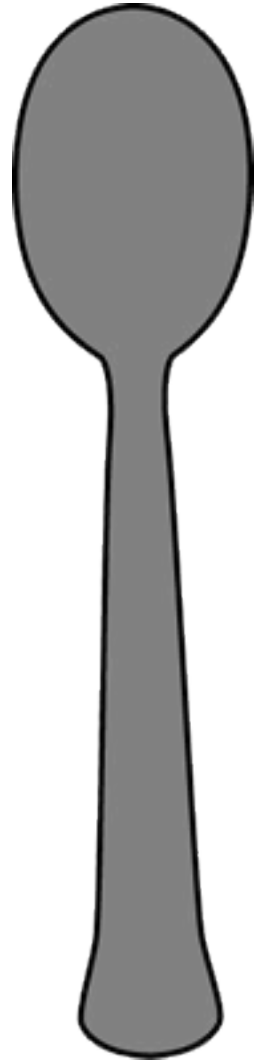
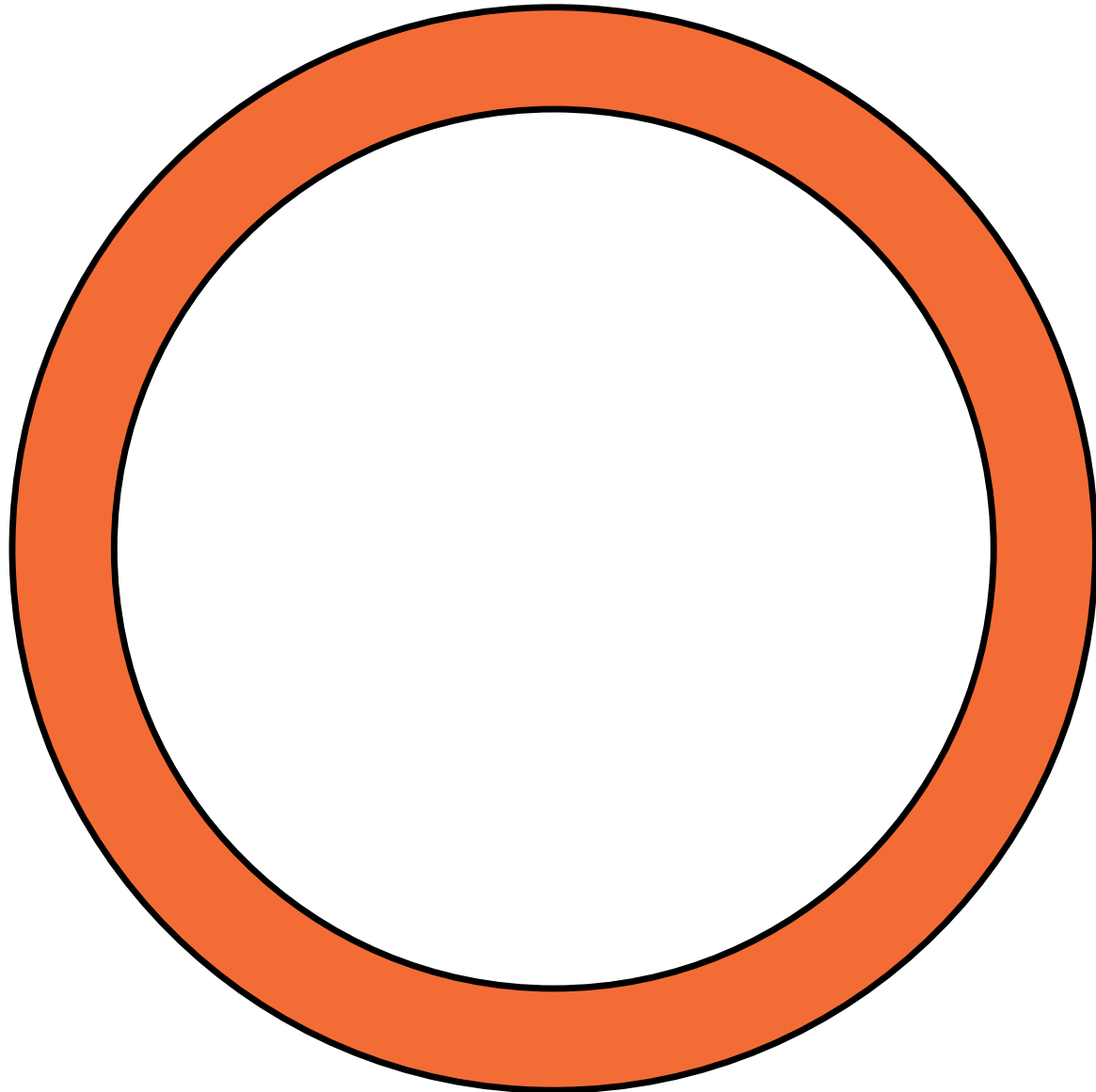
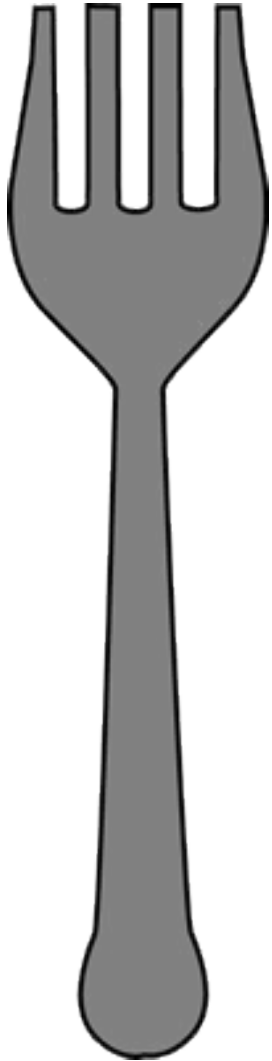

Eat a Rainbow!

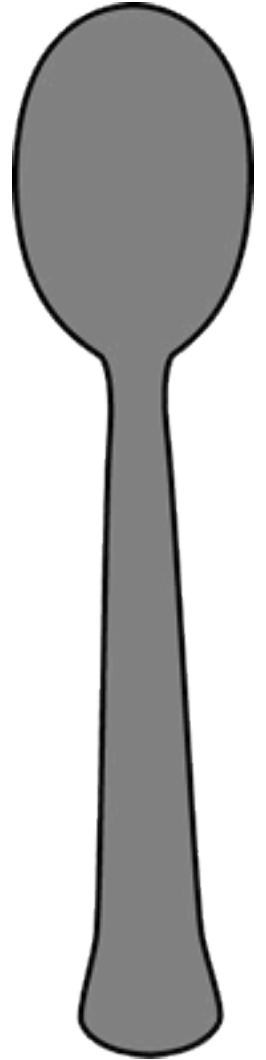
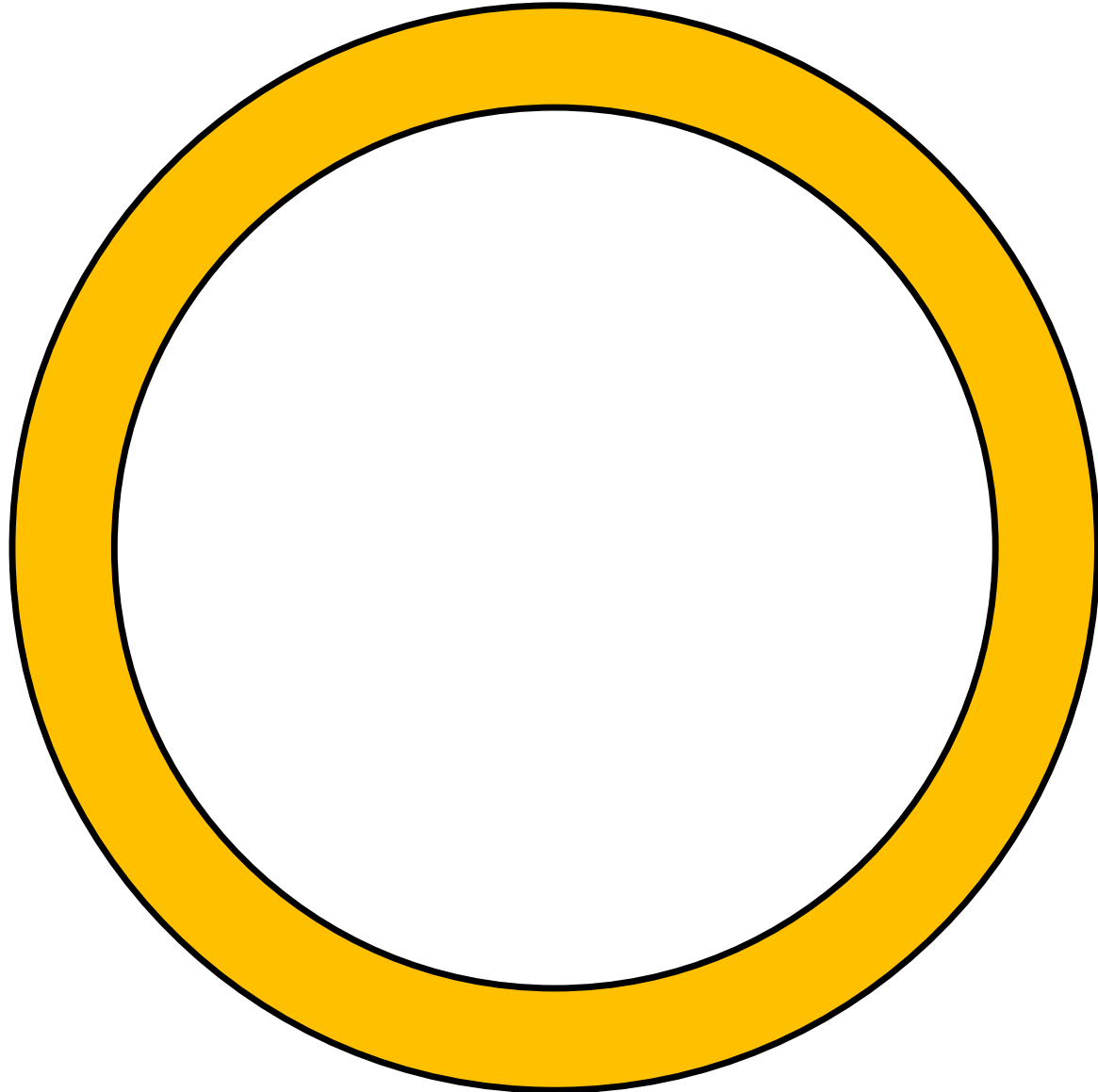
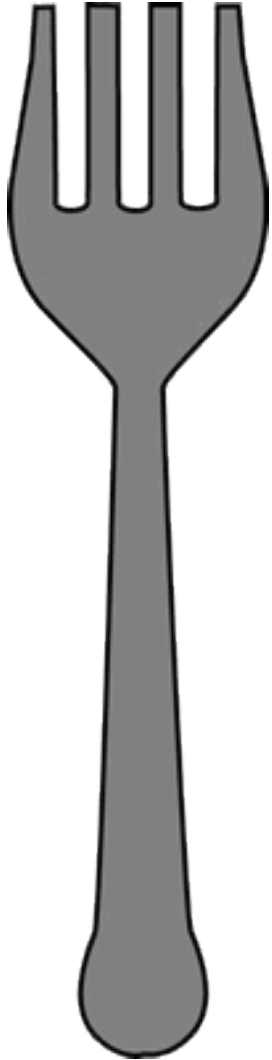

Eat a Rainbow!

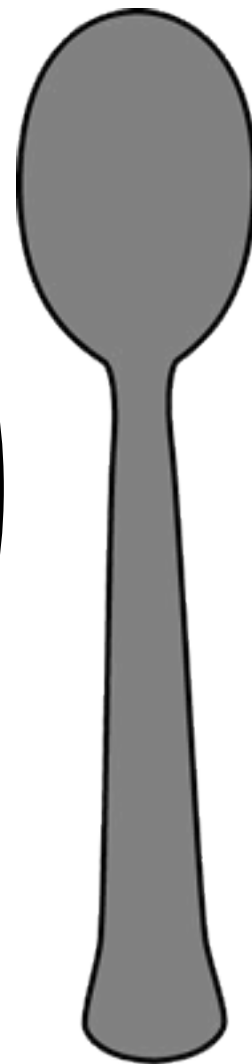
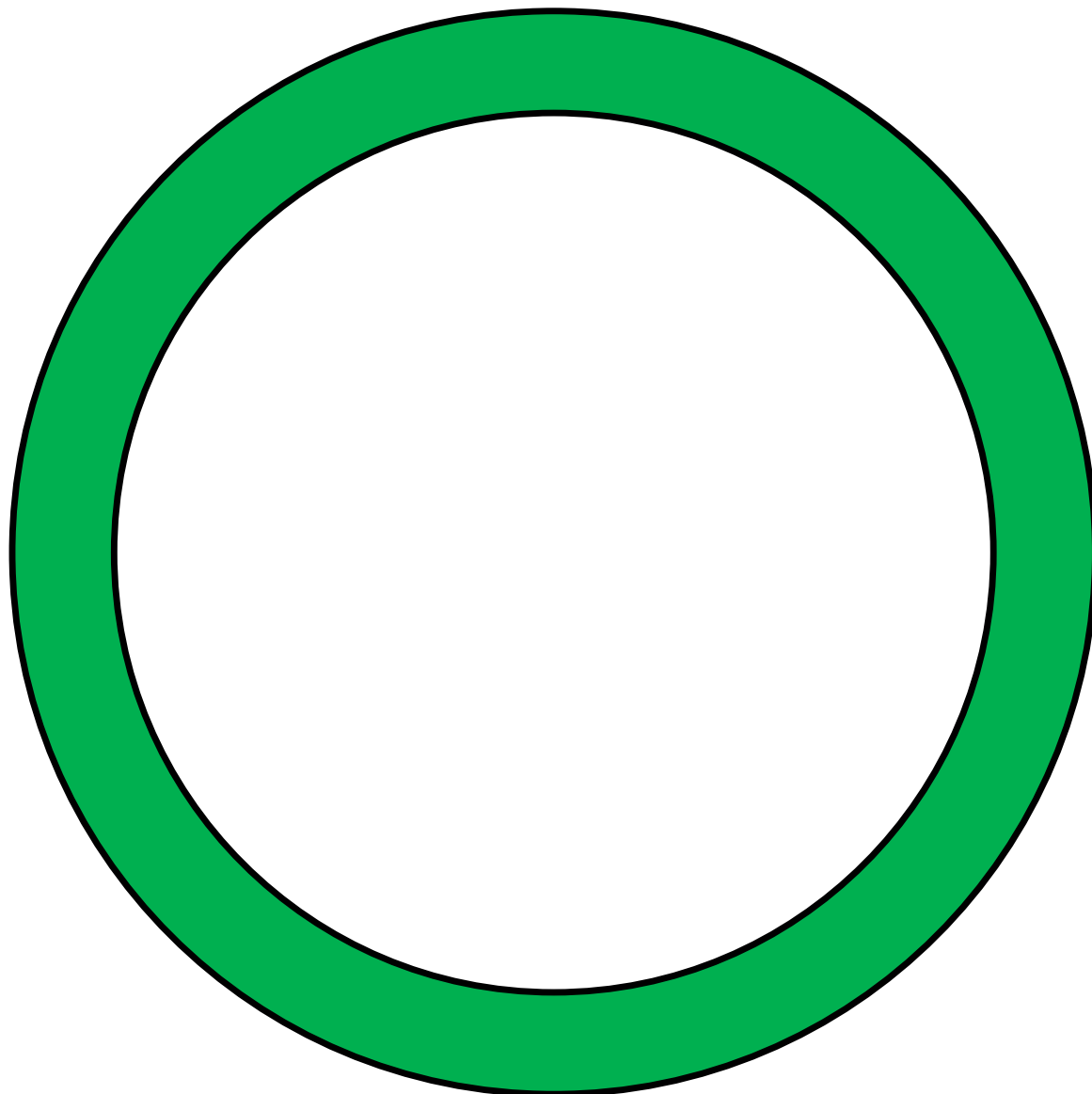
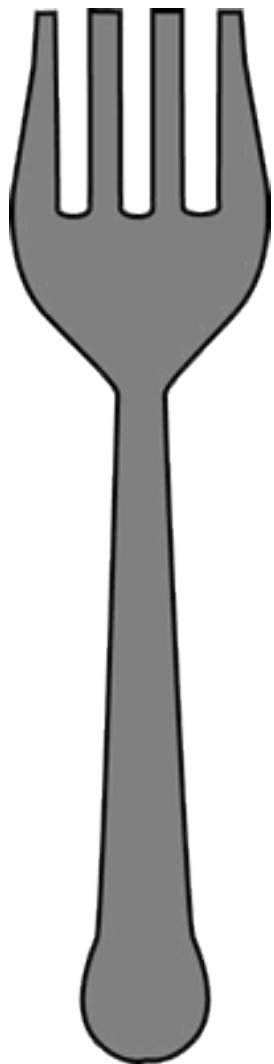

Eat a Rainbow!

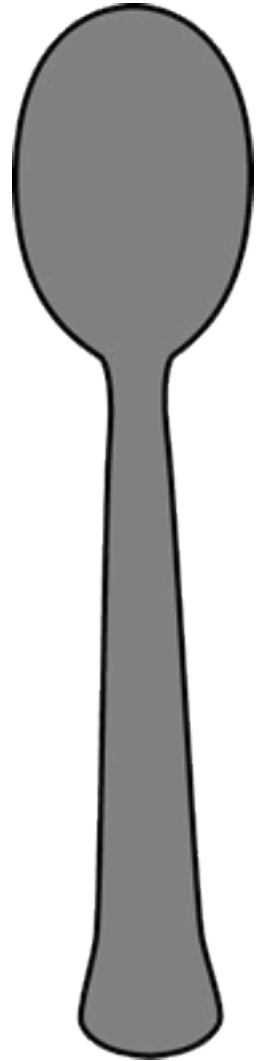
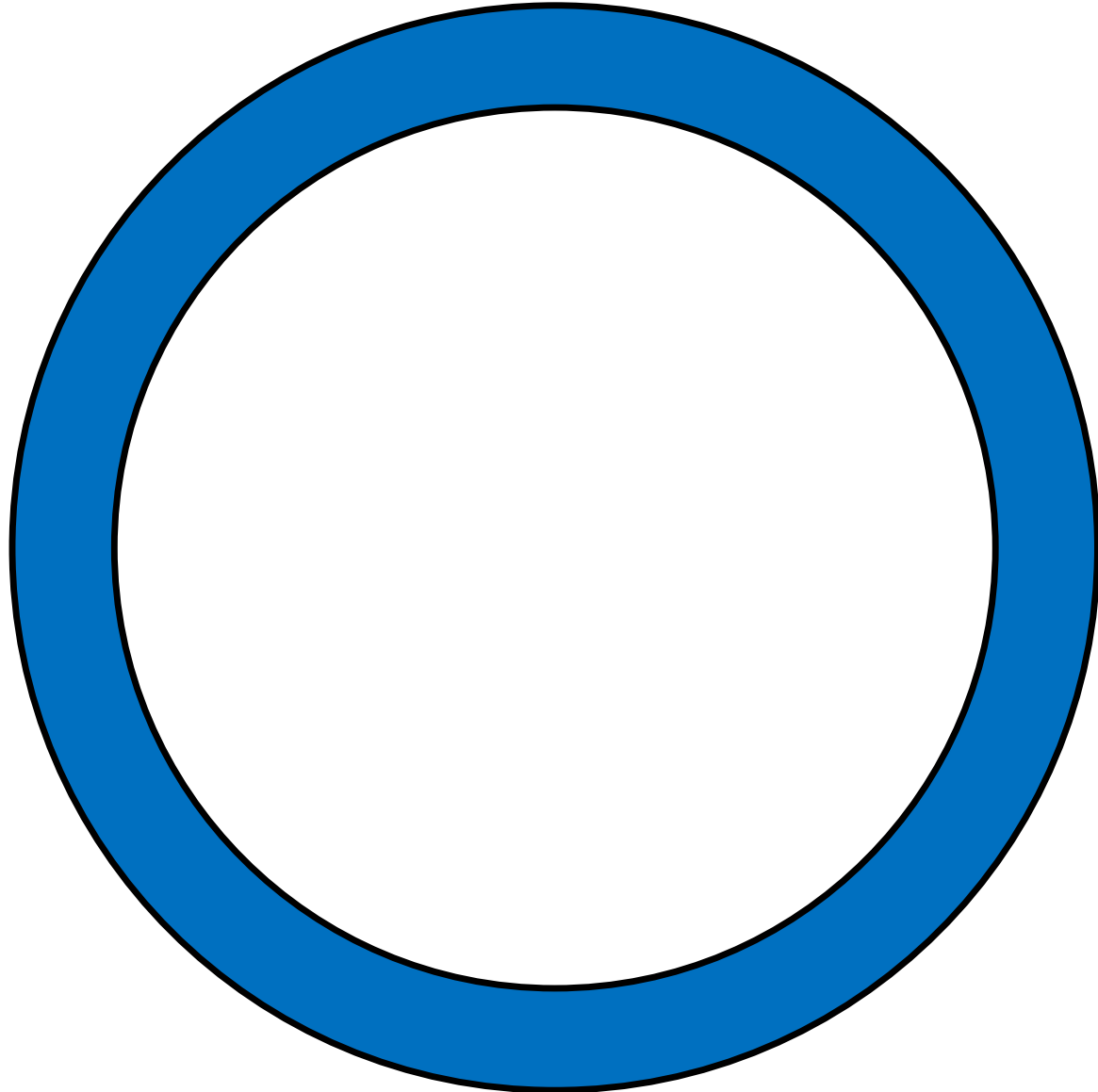
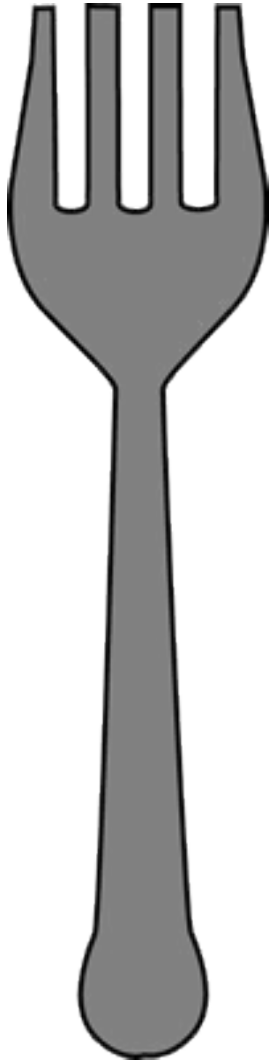

Eat a Rainbow!

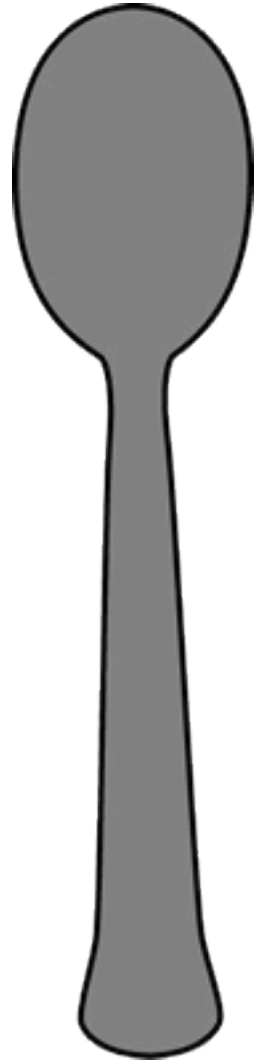
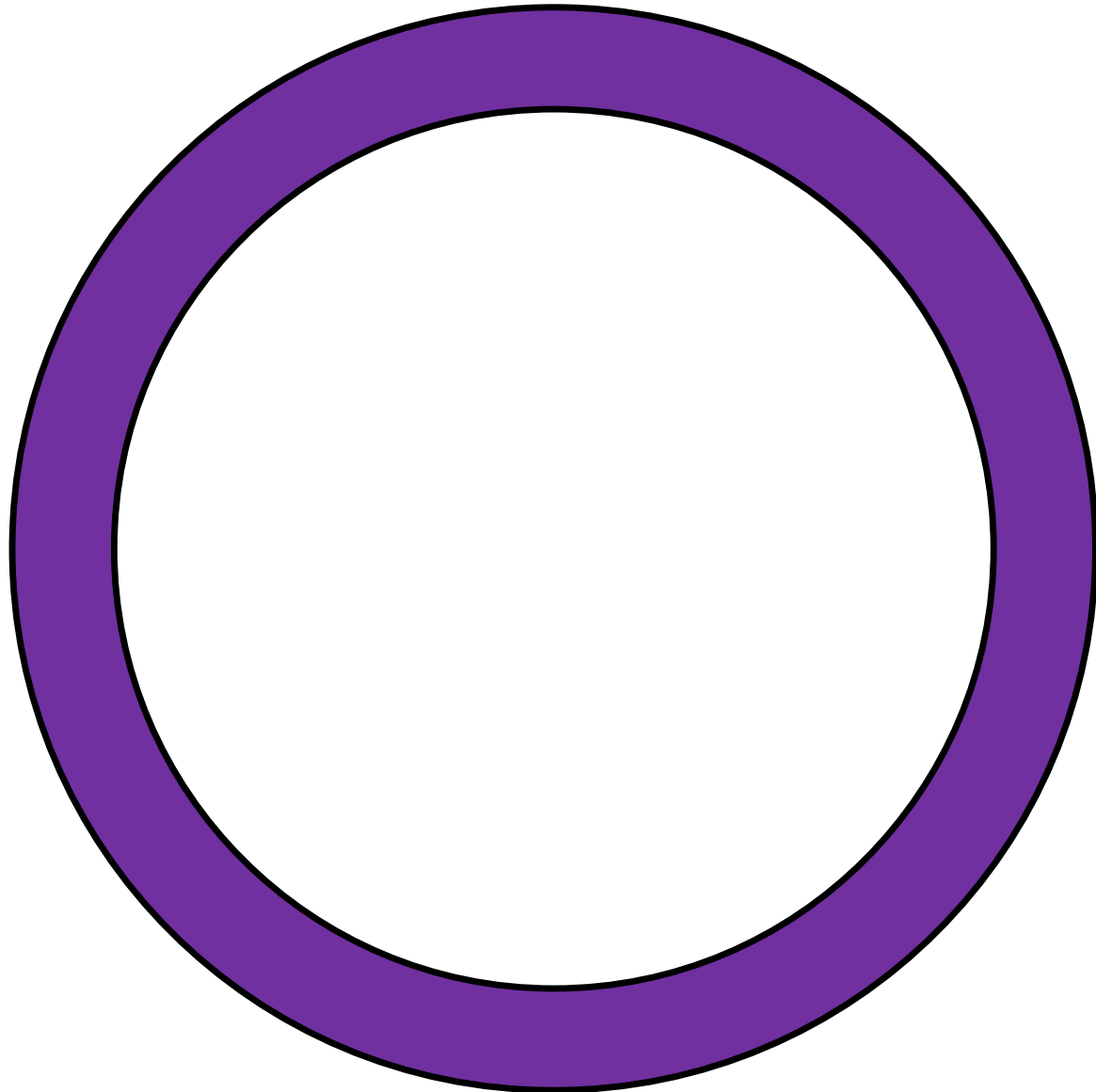
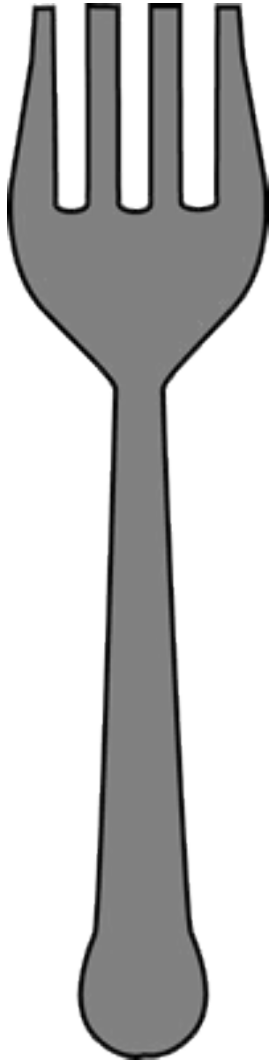

Eat a Rainbow!

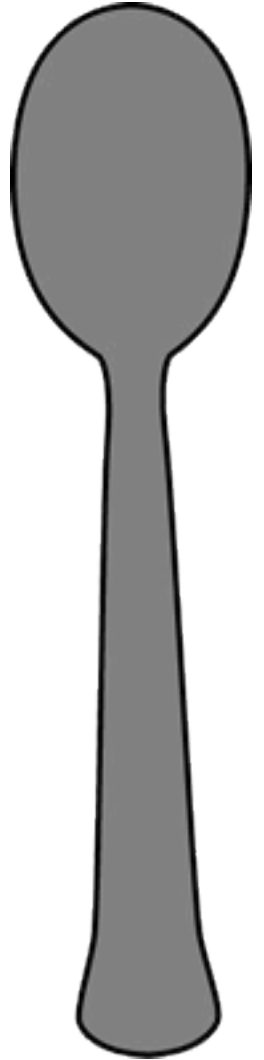
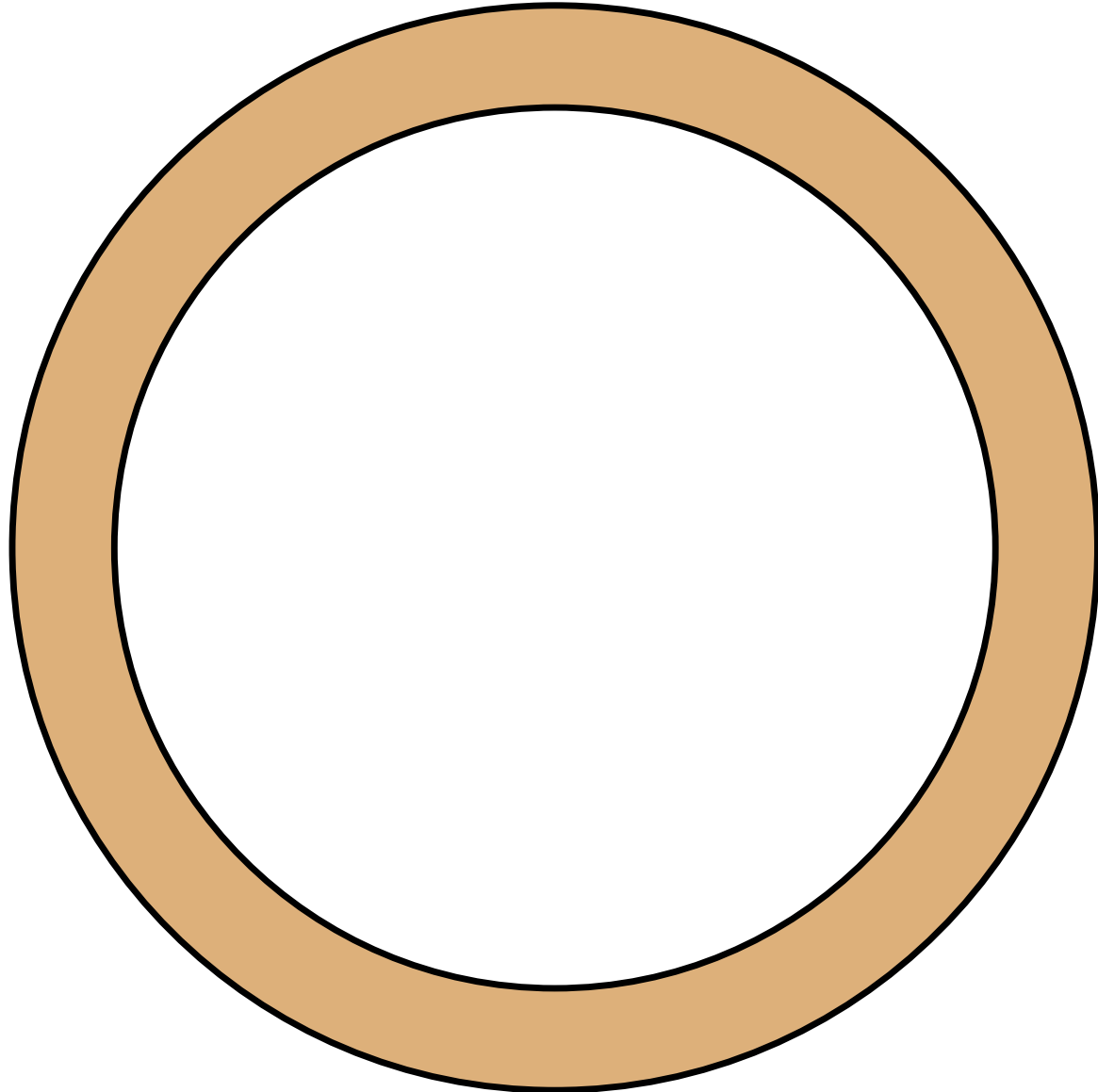
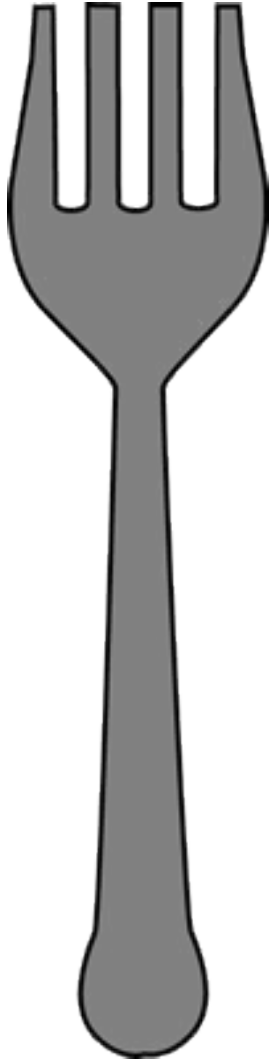

Eat a Rainbow

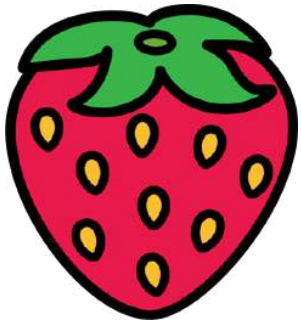

strawberry

Eat a Rainbow

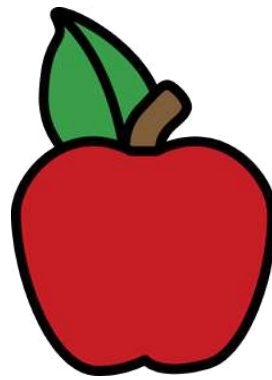

apple

Eat a Rainbow

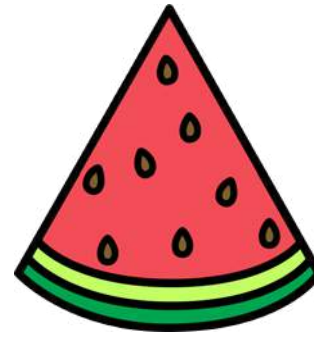

watermelon

Eat a Rainbow

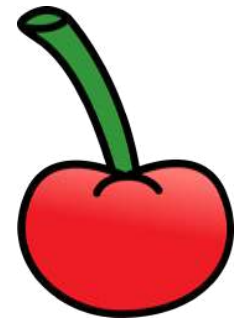

cherry

Eat a Rainbow



pumpkin

Eat a Rainbow

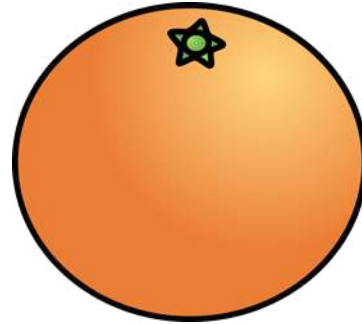

orange

Eat a Rainbow

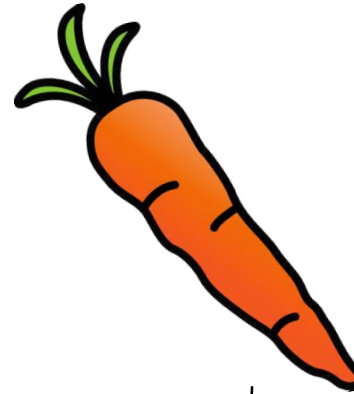

carrot

Eat a Rainbow

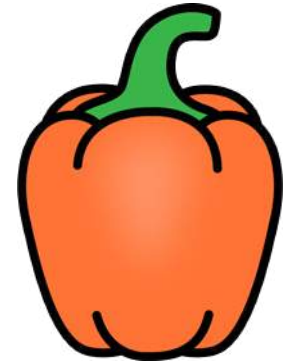

bell pepper

Eat a Rainbow

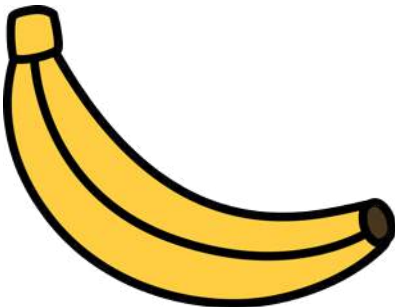

banana

Eat a Rainbow

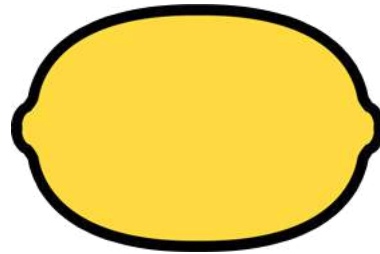

lemon

Eat a Rainbow

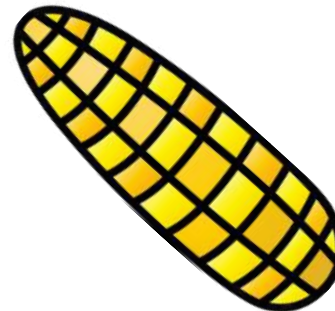

corn

Eat a Rainbow

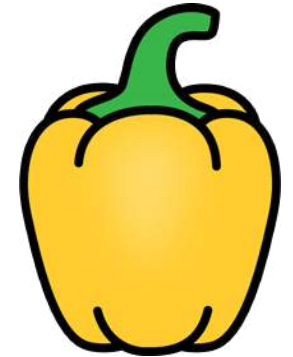

bell pepper

Eat a Rainbow



broccoli

Eat a Rainbow

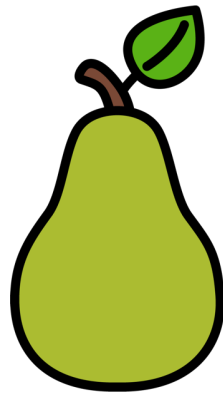

pear

Eat a Rainbow

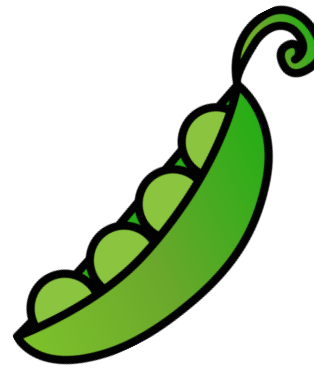

peas

Eat a Rainbow

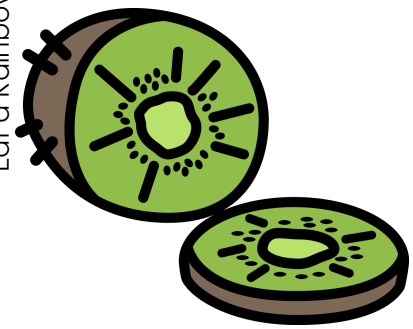

kiwi

Eat a Rainbow

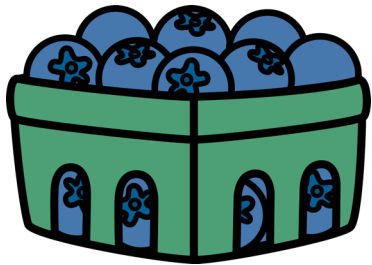

blueberries

Eat a Rainbow

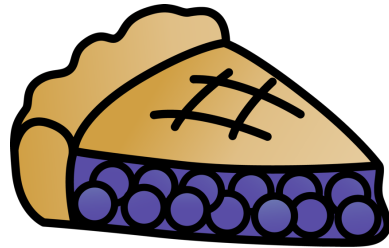

blueberry pie

Eat a Rainbow



blueberry ice cream

Eat a Rainbow

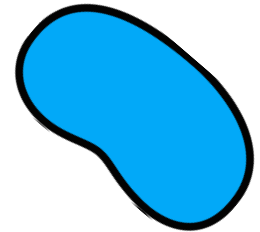

jelly bean

Eat a Rainbow

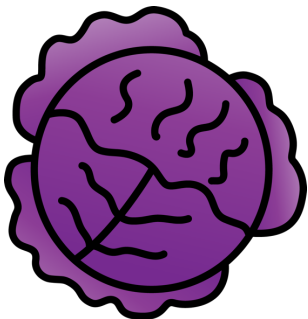

cabbage

Eat a Rainbow

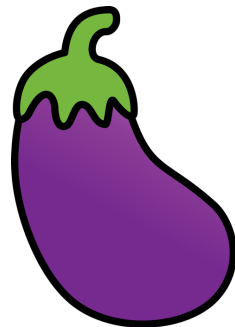

eggplant

Eat a Rainbow

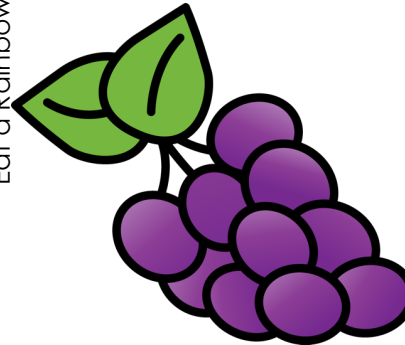

grapes

Eat a Rainbow

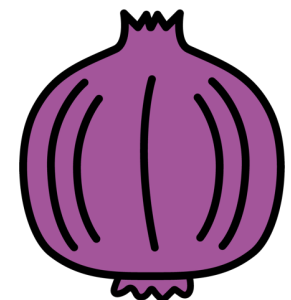

onion

Eat a Rainbow

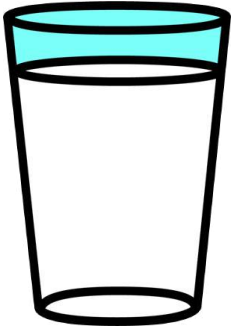

milk

Eat a Rainbow



cauliflower

Eat a Rainbow



vanilla ice cream

Eat a Rainbow

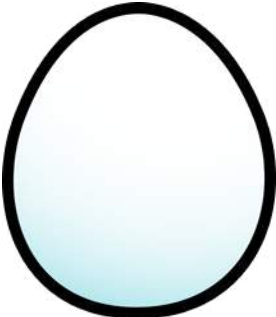

egg

Eat a Rainbow



bagel

Eat a Rainbow



spaghetti

Eat a Rainbow

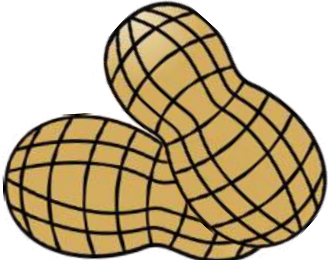

nuts

Eat a Rainbow



chicken

Count and Clip Cards

Objective: Students will practice one-to-one correspondence and number recognition to 12.

Preparation: Print the cards, mat, laminate and cut apart.

Procedure: Students count the pictures on each card and mark the correct answer with a clothes pin.

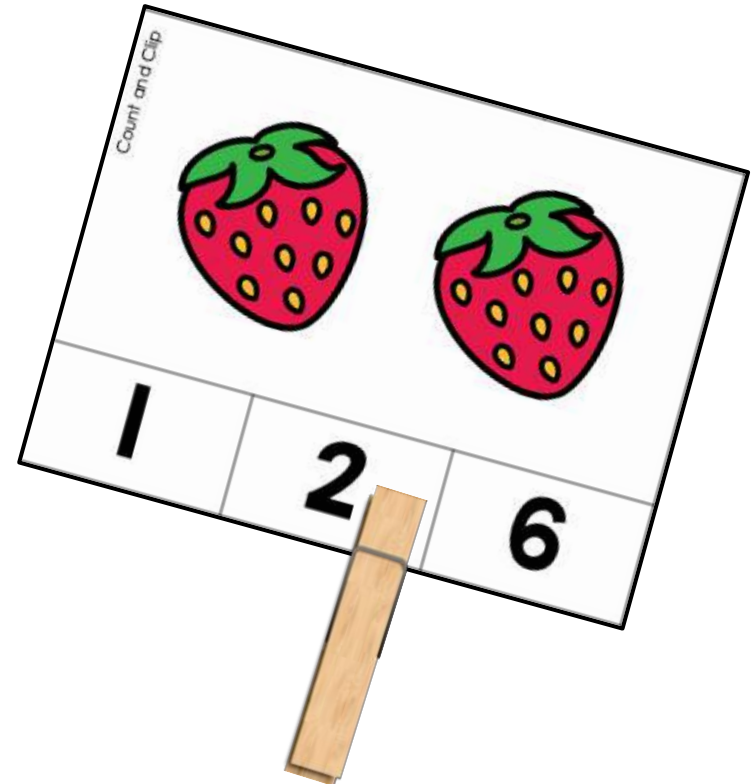
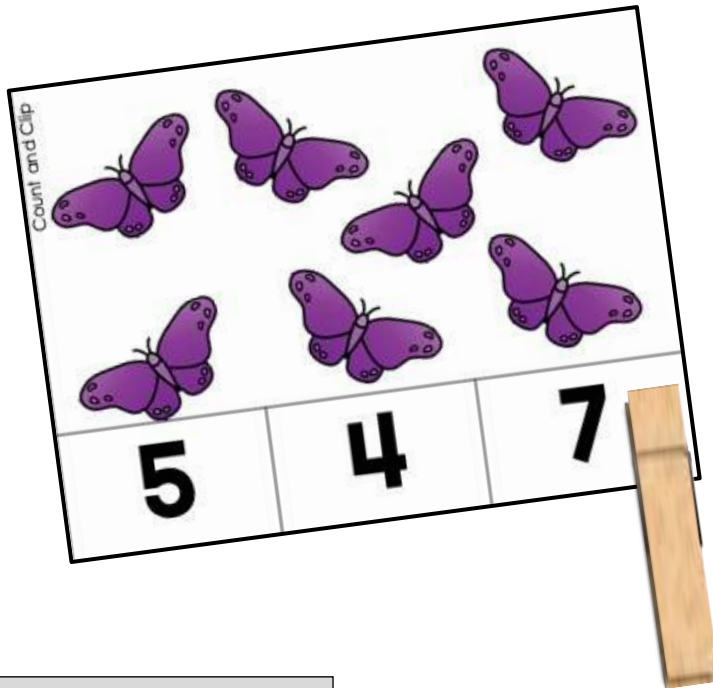

Helpful Hint:

For easy self-checking, put a sticker on the back that will match the clothes pin if the answer is correct.

Count and Clip

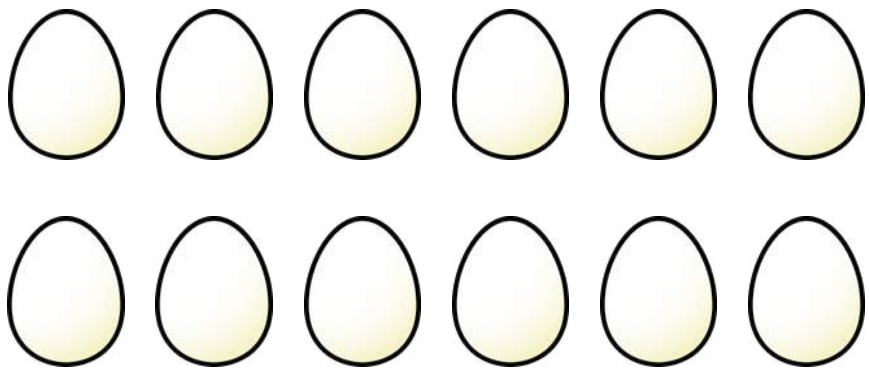

12

8

9

Count and Clip

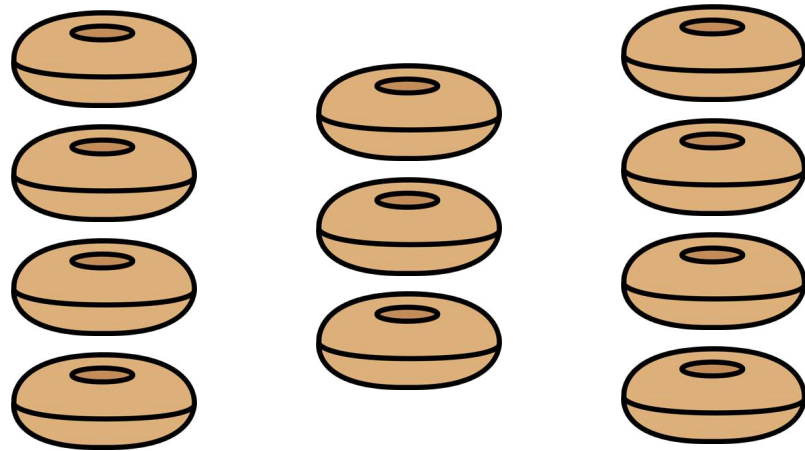

4

11

10

Count and Clip

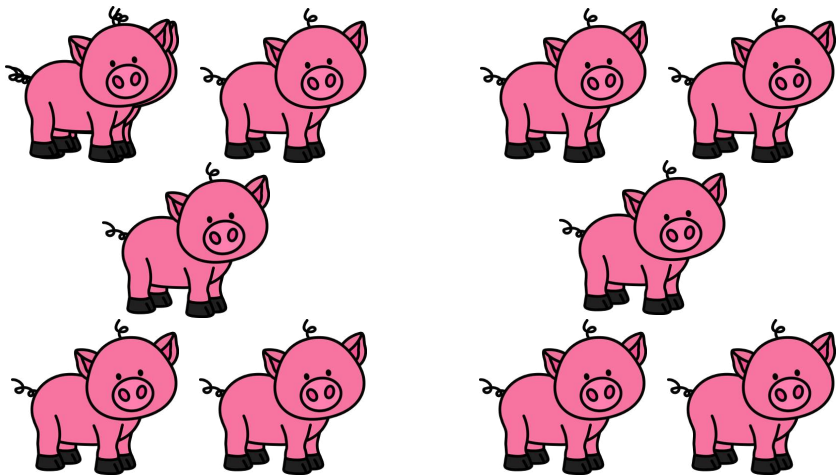

8

6

10

Count and Clip

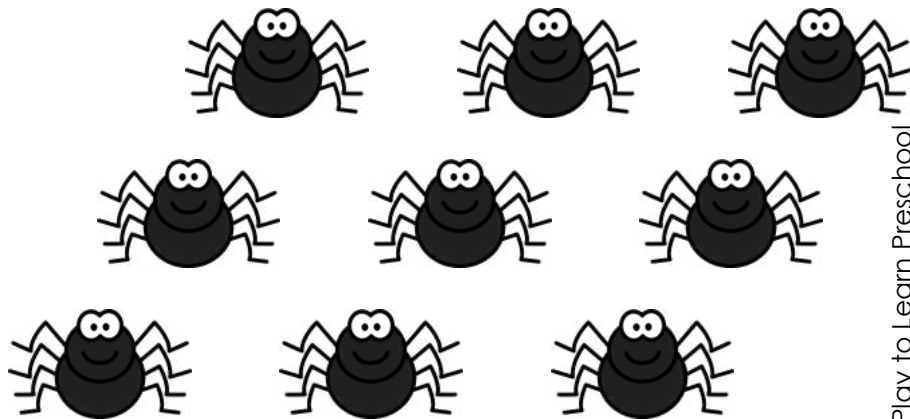

9

6

5

Count and Clip

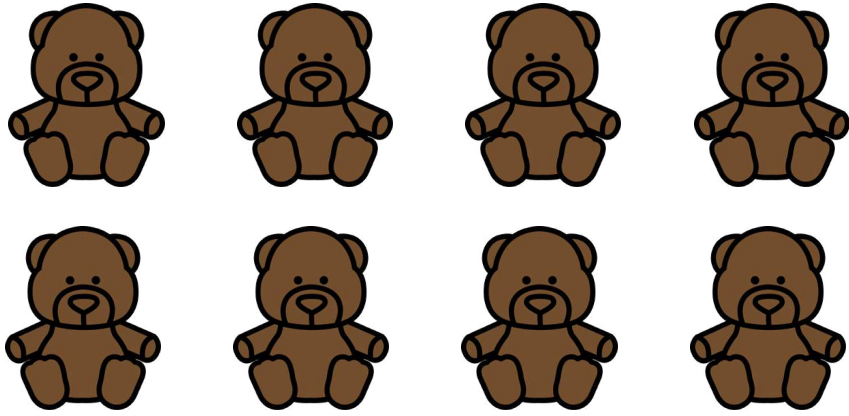

7

9

8

Count and Clip

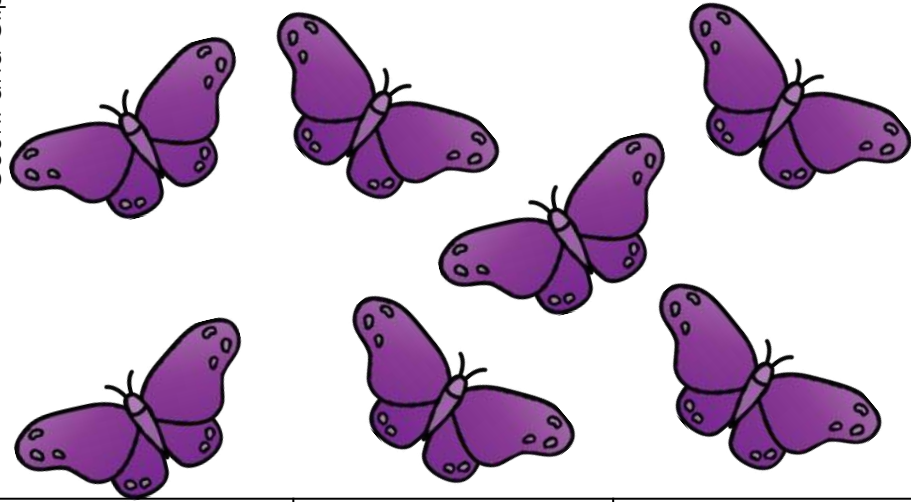

5

4

7

Count and Clip

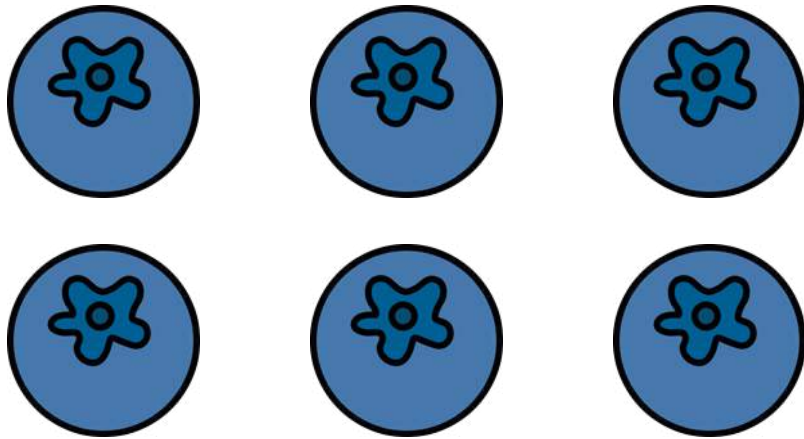

1

3

6

Count and Clip

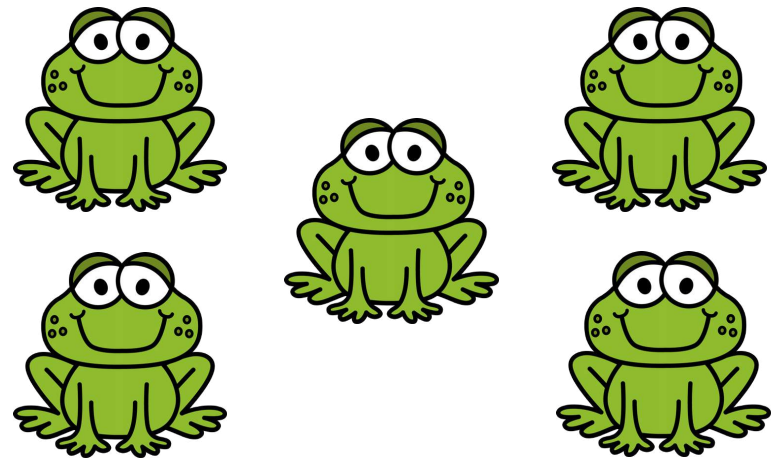

10

2

5

Count and Clip

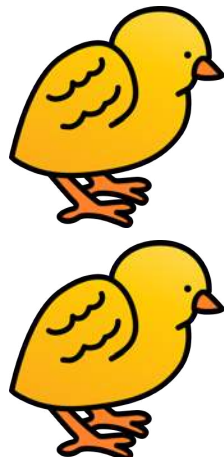
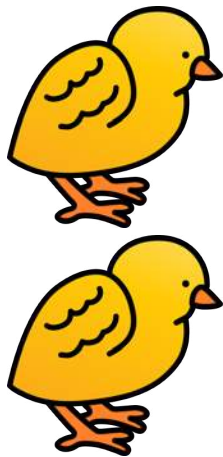

5

2

4

Count and Clip

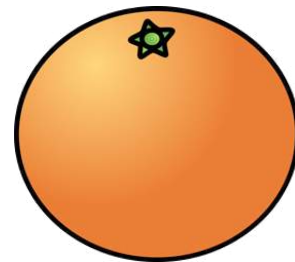
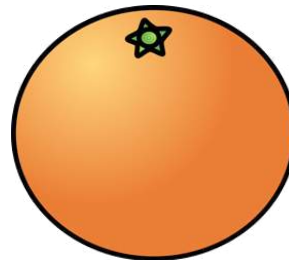
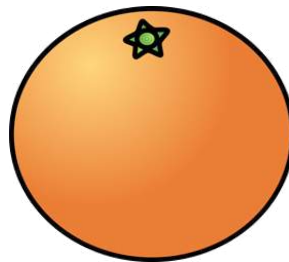

3

7

8

Count and Clip

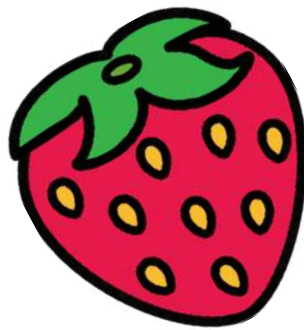
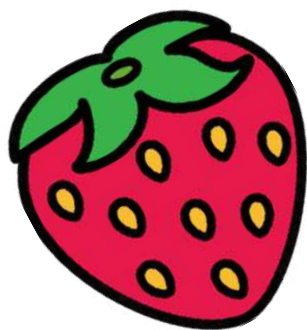

1

2

6

Count and Clip

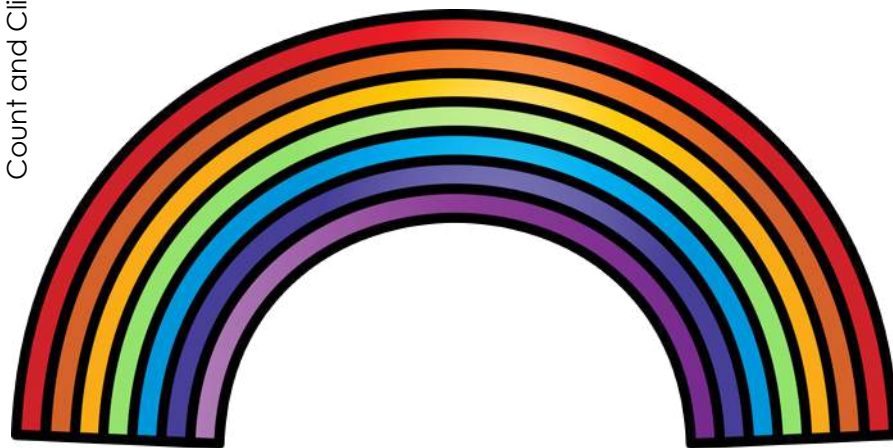

9

5

1

Concentration

Objectives: The students will use visual discrimination (matching) skills to identify two identical objects.

Preparation: Print the picture cards. Mat onto cardstock and/or laminate as desired. Cut apart.

Procedure: Place cards facing down. Students take turns flipping over 2 cards at a time. If the cards match, the student gets to keep the pair. If they don't match, they return them to the face-down position and try again.

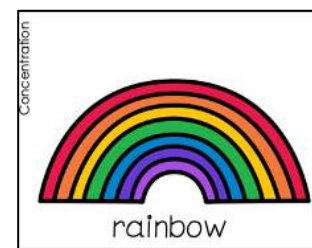
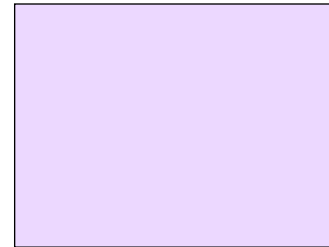
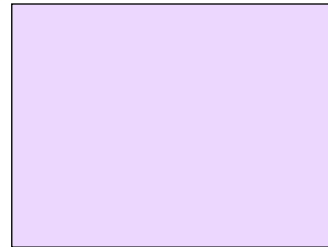
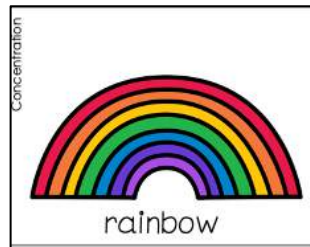

Concentration

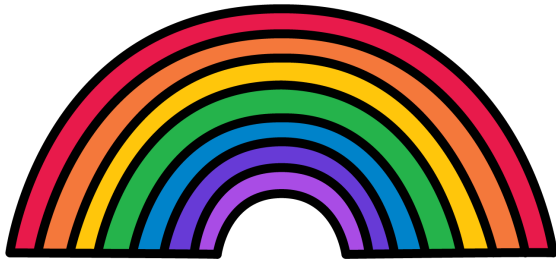

rainbow

Concentration

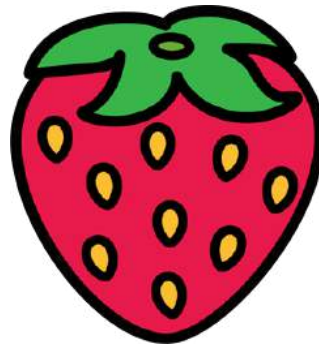

strawberry

Concentration



pumpkin

Concentration



traffic light

Concentration

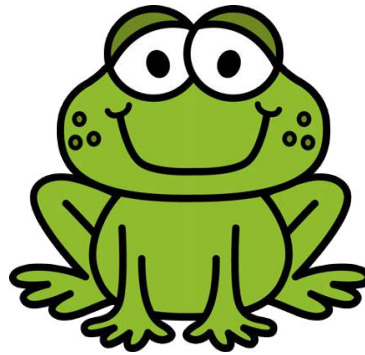

frog

Concentration

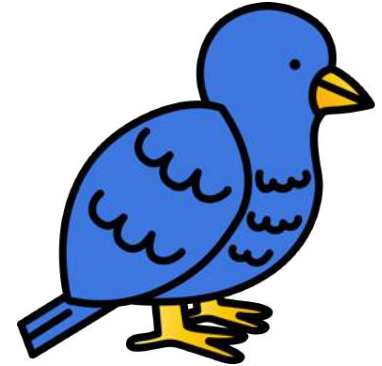

bluebird

Concentration

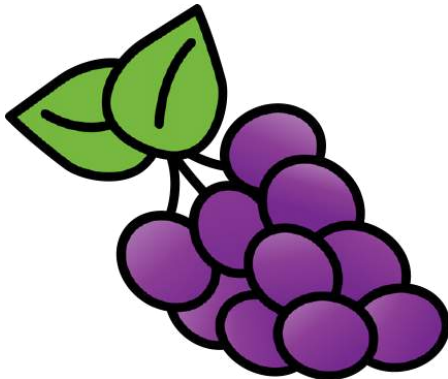

grapes

Concentration



flamingo

Concentration



bear

Concentration

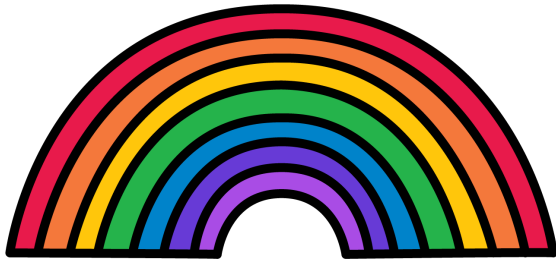

rainbow

Concentration

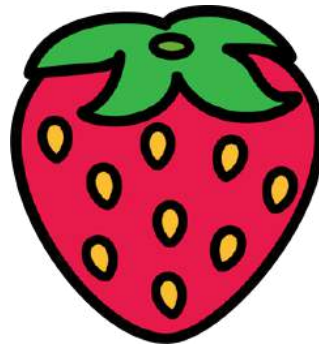

strawberry

Concentration



pumpkin

Concentration



traffic light

Concentration

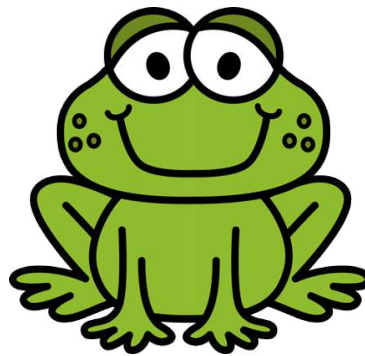

frog

Concentration

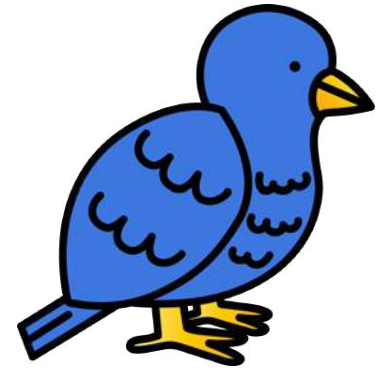

bluebird

Concentration

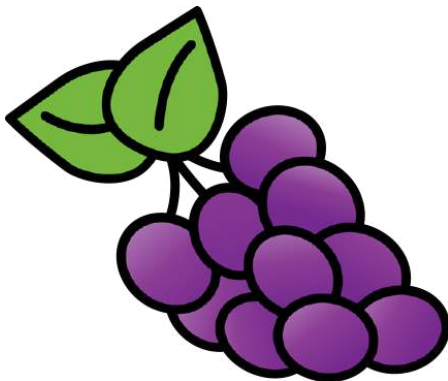

grapes

Concentration



flamingo

Concentration

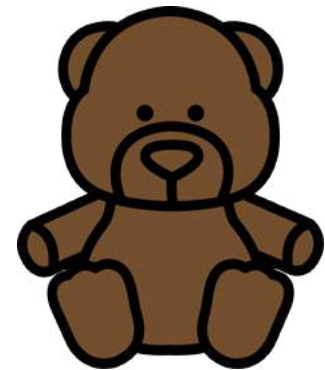

bear



Color Books

for Preschoolers



Colors

- *Teeny, Tiny Mouse A Book About Colors* by Laura Leuck
- *Purple, Green and Yellow* by Robert Munsch
- *Red A Crayon's Story* by Michael Hall
- *Five Colorful Crayons* by Lee Taylor
- *Pink is for Boys* by Robb Pearlman
- *Bear Sees Colors* by Karma Wilson & Jane Chapman
- *Brown Bear, Brown Bear, What do you See?* by Bill Martin Jr & Eric Carle
- *Pete the Cat: I Love My White Shoes* by Eric Litwin
- *The Artist Who Painted a Blue Horse* by Eric Carle
- *Lemons are Not Red* by Laura Vaccaro Seeger
- *Dog's Colorful Day* by Emma Dodd
- *Cat's Colors* by Airlie Anderson
- *Little Green Peas* by Keith Baker
- *A Color of his Own* by Leo Lionni
- *Monsters Love Colors* by Mike Austin
- *The Mixed-Up Chameleon* by Eric Carle
- *Penguins Love Colors* by Sarah Aspinall
- *Festival of Colors* by Kabir and Surishtha Sehgal

Mixing Colors

- *White Rabbit's Color Book* by Alan Baker
- *Color Dance* by Ann Jonas
- *Mixed: A Colorful Story* by Arree Chung
- *Little Blue and Little Yellow* by Leo Lionni
- *Mouse Paint* by Ellen Stoll Walsh
- *I Love Colors* by Hans Wilhelm
- *Mix it Up!* by Herve Tullet
- *Blue vs. Yellow* by Tom Sullivan

Rainbows

- *What Makes a Rainbow* by Betty Ann Schwartz
- *Rainbow Duck* by Yvette Lodge
- *Ava and the Rainbow (Who Stayed)* by Ged Adamson
- *Planting a Rainbow* by Lois Ehlert
- *Duckie's Rainbow* by Frances Barry
- *A Rainbow of My Own* by Don Freeman
- *Black is a Rainbow Color* by Angela Joy
- *Rainbow Stew* by Cathryn Falwell

More resources

for preschool and Pre-K learners:

Connect:



[Newsletter](#)

[Facebook](#)

[Instagram](#)

[Blog](#)

[Pinterest](#)

Printable Resources for

Preschool Learners

Credit:

These talented artists made this possible.



Terms of Use:

Play to Learn resources are for personal classroom and home use only. They may not be used commercially.

YES:

- You may use this resource at home with your own children or in your classroom with your own students.
- You may print copies for your own children or students.
- You may send printed copies home with your students.
- You may use these lessons yourself to provide virtual teaching videos for your own students who might be learning at home.

NO:

- You may NOT post this file to any file sharing website. (DropBox, Google Drive, Facebook, Amazon, SeeSaw, etc.)
- You may NOT resell these resources.
- You may NOT send these PDFs via email for students to print at home.
- You may NOT share these PDFs with colleagues via email or otherwise.
- You may not claim these resources or ideas as your own.
- You may NOT use these resources to teach lessons that you **sell** online. (Teaching your own students – great. Selling these lessons, even if you do them yourself, online – not permitted.) This includes OutSchool and similar platforms.

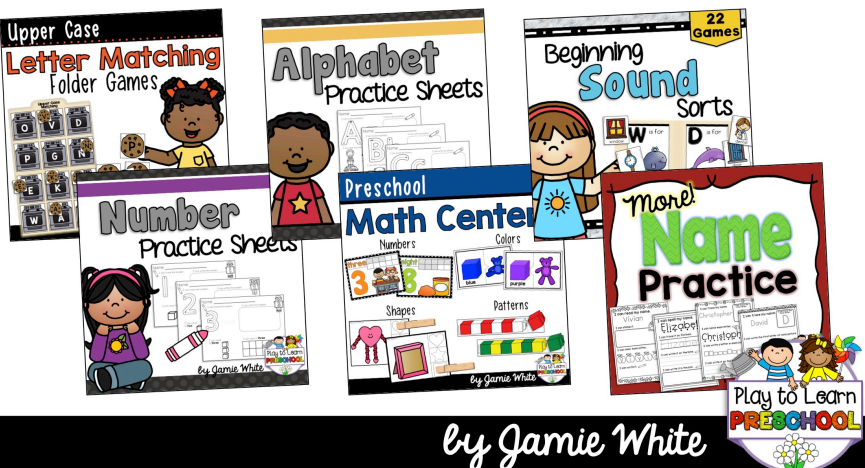

By Jamie White



Find literacy, math, name practice, dramatic play, and unit lesson plans for preschool students.