

Circle Time

Fire Safety

Mini-Unit for Preschoolers



Hurry, hurry action cards

drive the firetruck

Hurry, hurry action cards

climb the ladder

Hurry, hurry action cards

back to the station

Hurry, Hurry, Drive the Firetruck!

Action Song

Hurry, hurry, drive the fire truck.
(hold and turn a pretend steering wheel)

Hurry, hurry, drive the fire truck.
Hurry, hurry, drive the fire truck.
Ding, ding, ding, ding, ding!
(ring the bell)

Repeat with verses:

- Turn the corner
(lean left, then right)
- Climb the ladder
(pretend to climb a ladder)
- Spray the water
(pretend to spray a hose)
- Back to the station
(slowly lean left, then right)

Play to Learn Preschool



Circle Time Lessons

Day 1 Introduction - Fire Safety

Introduce the mini unit: **Fire Safety**

Learn ways to stay safe in dangerous situations by singing a song and acting out a poem.

Day 2 Firefighter

Look at the real pictures of firefighters. Label the firefighter and play a carpet game.

Day 3 Stop, Drop, and Roll

Play the "Stop, Drop, and Roll" action spinner game and find what's missing in the Grid Game.

Day 4 Tell a Grown-up

Look at the real pictures. Play "Captain Says" and a sorting game.

Day 5 Conclusion

Play the riddle game and write about what the students have learned.

Introduction

What is Fire Safety?

Teaching young learners about fire safety is important. Students need to understand the dangers and how to respond when they see fire or smoke. Please follow your organization's guidelines when practicing your fire drill.

Objectives:

- The students will demonstrate basic locomotor skills.
- The students will follow oral directions.

Activities:

- Show the real photos. Ask students if they have seen a red fire truck or firefighter.
- Recite and act out the "Hurry, Hurry, Drive the Fire Truck" poem/simulation song.
- Read the poem "Fire Drill". Students will act out the parts to practice a fire drill.

Extension Idea:

Assign your local fire department to ask if they would come and talk to the students about fire safety.

Day 1 lesson plans

Firefighter

Local Items

Firefighters wear a lot of gear to protect themselves from fire and smoke. When children can see what firefighters wear, it can be less scary to see one in real life.

Objectives:

- The students will use new vocabulary.
- The students will demonstrate an understanding of print concepts.
- The students will share and take turns with others.

Activities:

- Show the real pictures of the firefighters and their gear. Consider having a real firefighter come to speak to the class. Children may feel more at ease when they realize a real person is behind the mask.
- Label the different parts of the firefighter. Discuss why each item is important to a firefighter.
- Play a carpet game and explain that firefighters use the hydrant to water a fire. Use the cards for your students.

Where's the Hoop? Whose is the Hoop?

Place a number on each hoop. Play to learn numbers.

Day 2 lesson plans

Stop, Drop, and Roll

Crawl Under Snake

Show the students the safest way to respond to smoke in the room by dropping down and crawling to safety. If flames catch on fire, teach them to stop, drop, and roll.

Objectives:

- Students will demonstrate basic locomotor skills.
- The students will express themselves using words and sentences.

Activities:

- Look at the picture. Practice crawling with the students. Talk about "stop, drop, and roll" if catches catch on fire.
- Play a version of snakes dance with the fire safety action wheel. Play some music, spin the wheel and the act out the motion until the music stops. Assembly directions included on spinner page.
- Play the Grid game.

To Play:

- Copy, laminate page and cut out pieces of paper.
- Create a grid where each square has the action from instructions in the lesson book. Discuss the pattern and materials of the snake.
- Students close their eyes until the teacher releases the snake.
- Students use their knowledge of patterns to remember where the snake and where it's moving.

Extension Idea: Use chalk to draw snakes on the ground outside or on paper. If a water bottle and soap the bottles until they disappear.

Day 3 lesson plans

Tell a Grown-up

Staying Safe

It is important for young learners to understand what to do if they see something dangerous. Identify items that are dangerous then, tell an adult.

Objectives:

- The students will notice similarities and differences and ask questions.
- The students will sort pictures by property.
- The students will demonstrate basic locomotor skills.

Activities:

- Show the real pictures to the students and discuss when it is important to "tell a grown-up" if they see something dangerous.
- Play the "Safe/Not Safe" pocket chart game.
- Give two thumbs up if the picture is safe. Give one thumb down if it is not safe. Play "Like Simon Says". Have the students act out their items.

Captain Says

Play to learn numbers.

Day 4 lesson plans

Conclusion

What We Knew

To conclude the unit, ask the students to describe what they have learned about fire safety.

Objectives:

- The students will actively participate in conversations.
- The students will interact and participate in circle time.

Activities:

- Invite the students to tell the things they have learned about fire safety. Write their ideas on index cards or the hydrant cards provided.
- Read the riddle while the students practice their active listening skills. They guess the answer to the question and then double check the answer card inside the bag. Please adjust the riddle answers to the guidelines of your organization.

Extension Idea: Make a memory tray with a small fire safety-themed bag. Drawers (think: the room by firefighter sound). Show the students the bag and then have them close their eyes as they go into the bag slowly. Have them guess which bag is missing.

Day 5 lesson plans

Introduction

What is Fire Safety?

Day
Lesson
Plans

Teaching young learners about fire safety is important. Students need to understand the dangers and how to respond when they see fire or smoke. Please follow your organization's guidelines when practicing your fire drills.

Objectives:

- The students will demonstrate basic locomotor skills.
- The students will follow oral directions.

Activities:

1. Show the real photos. Ask students if they have seen a real fire truck or firefighter.
2. Recite and act out the "Hurry, Hurry, Drive the Firetruck" poem/action song.
3. Read the poem "Fire Drill", students will act out the parts to practice a fire drill.



Extension Idea:

Contact your local fire department to ask if they would come out and talk to the students about fire safety.





A fire station has a lot of equipment used to help fight fires.



**Fire trucks have hoses, water,
and other tools to put out fires.**



Smoke detectors and fire alarms help alert people to fires.

Hurry, Hurry, Drive the Firetruck!

Action Song

Hurry, hurry, drive the fire truck.

(hold and turn a pretend steering wheel)

Hurry, hurry, drive the fire truck.

Hurry, hurry, drive the fire truck.

Ding, ding, ding, ding, ding!

(ring the bell)

Repeat with verses:

- Turn the corner
(lean left, then right)
- Climb the ladder
(pretend to climb a ladder)
- Spray the water
(pretend to spray a hose)
- Back to the station
(slowly lean left, then right)





drive the firetruck



turn the corner

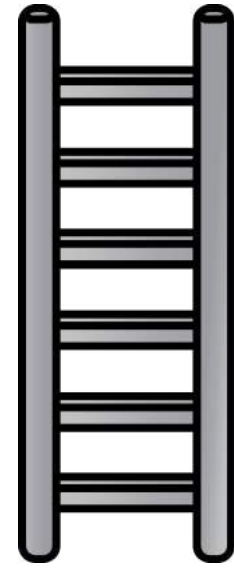

climb the ladder



spray the water



back to the station

Fire Drill

Directional Poem

Fire alarm, fire alarm, why so loud?
Are you trying to *alert* the crowd?



Beep, beep, womp, womp! Time to stand up!
Watch the teacher and *line right up*.



Mouth is closed. No talking allowed.
We need to *hear* directions for the crowd.



One by one, we walk down the hall.
Outside is our *meeting spot*. Stand so tall!



Teacher *counts* us one by one.
Almost time to go back to our fun.



We are all here, *safe* and sound.
So glad to have my friends around.





Fire alarm, fire alarm,
Why so LOUD?
Are you trying
To *alert* the crowd?

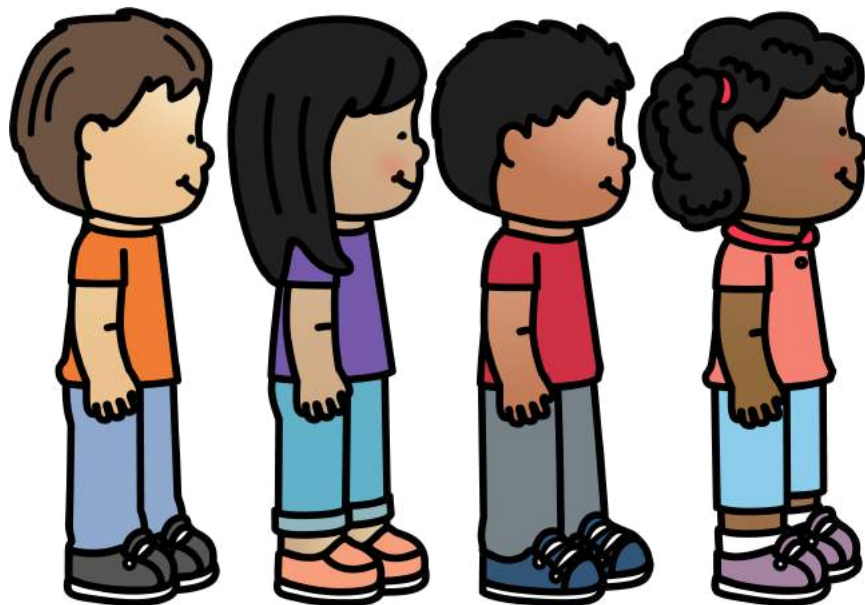

Beep, Beep, Womp, Womp!
Time to stand up!
Watch the teacher and
Line right up!

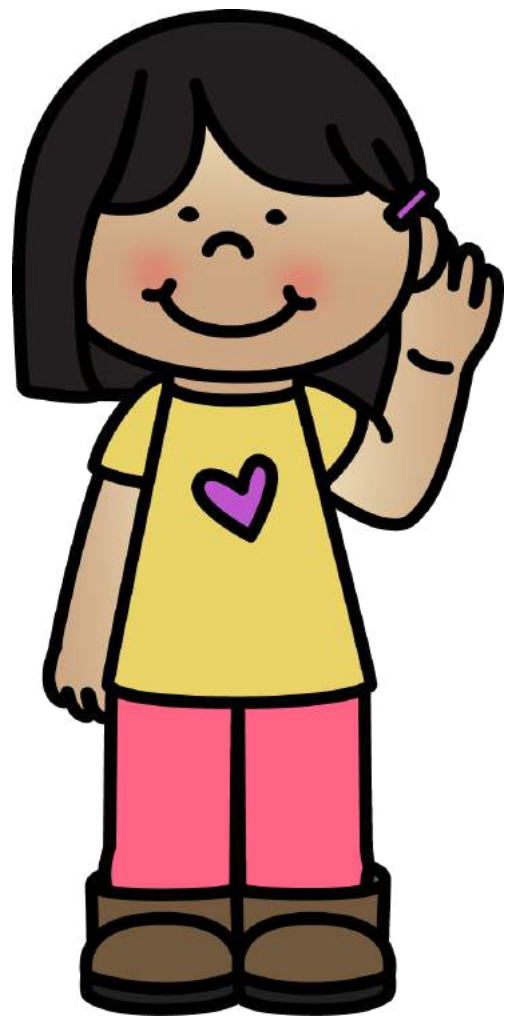

Mouth is closed.
No talking allowed.
We need to hear directions
For the crowd.

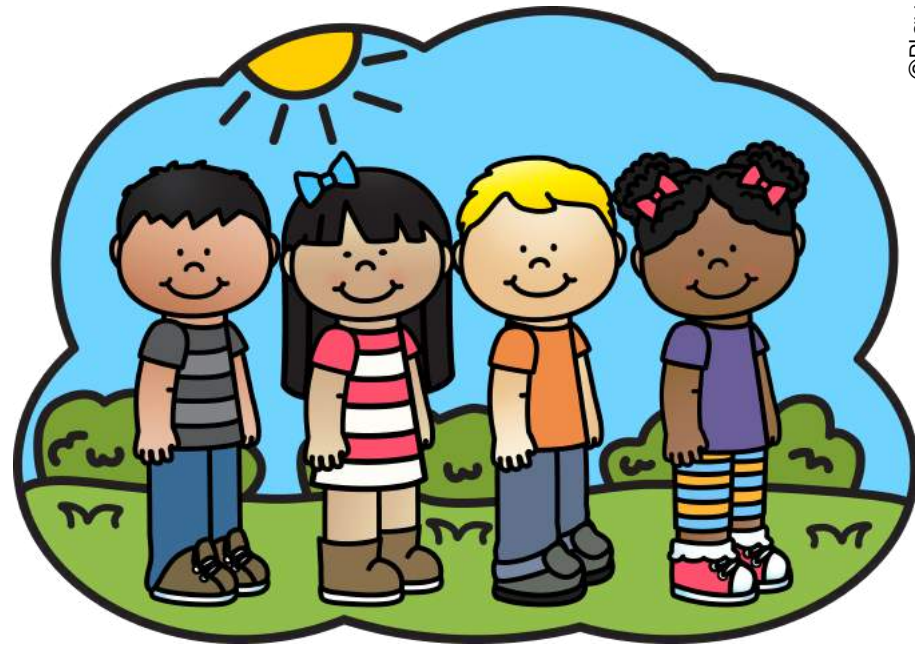

One by one,
We walk down the hall.
Outside is our meeting spot.
Stand so tall!



Teacher counts us,
One by one.
Almost time
To go back to our fun.



We are all here,
Safe and sound.
So glad to have
My friends around!

Firefighter

Local Heroes

Day 2
lesson
plans

Firefighters wear a lot of gear to protect themselves from fire and smoke. When children can see what firefighters wear, it can be less scary to see one in real life.

Objectives:

- The students will use new vocabulary.
- The students will demonstrate an understanding of print concepts.
- The students will share and take turns with others.

Activities:

1. Show the real pictures of the firefighters and their gear. Consider having a real firefighter come to speak to the class. Children may feel more at ease when they realize a real person is behind the mask.
2. Label the different parts of the firefighter. Discuss why each item is important to a firefighter.
3. Play the "Where's the hose?" carpet game and explain that firefighters use a wrench to open the fire hydrants so water can flow. Use the numbers that are appropriate for your students.



Extension Idea: Teach the ASL sign for "firefighter." Place the back of your hand on your forehead with your palm out. Touch your forehead with the back of your hand twice.

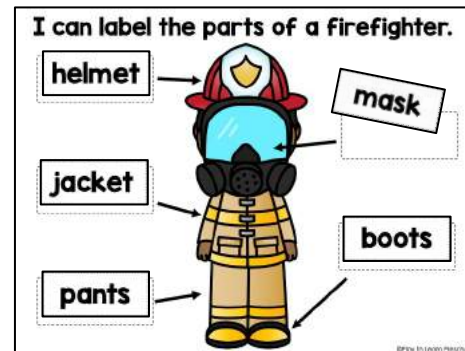



Firefighters wear helmets to protect their heads from falling debris.

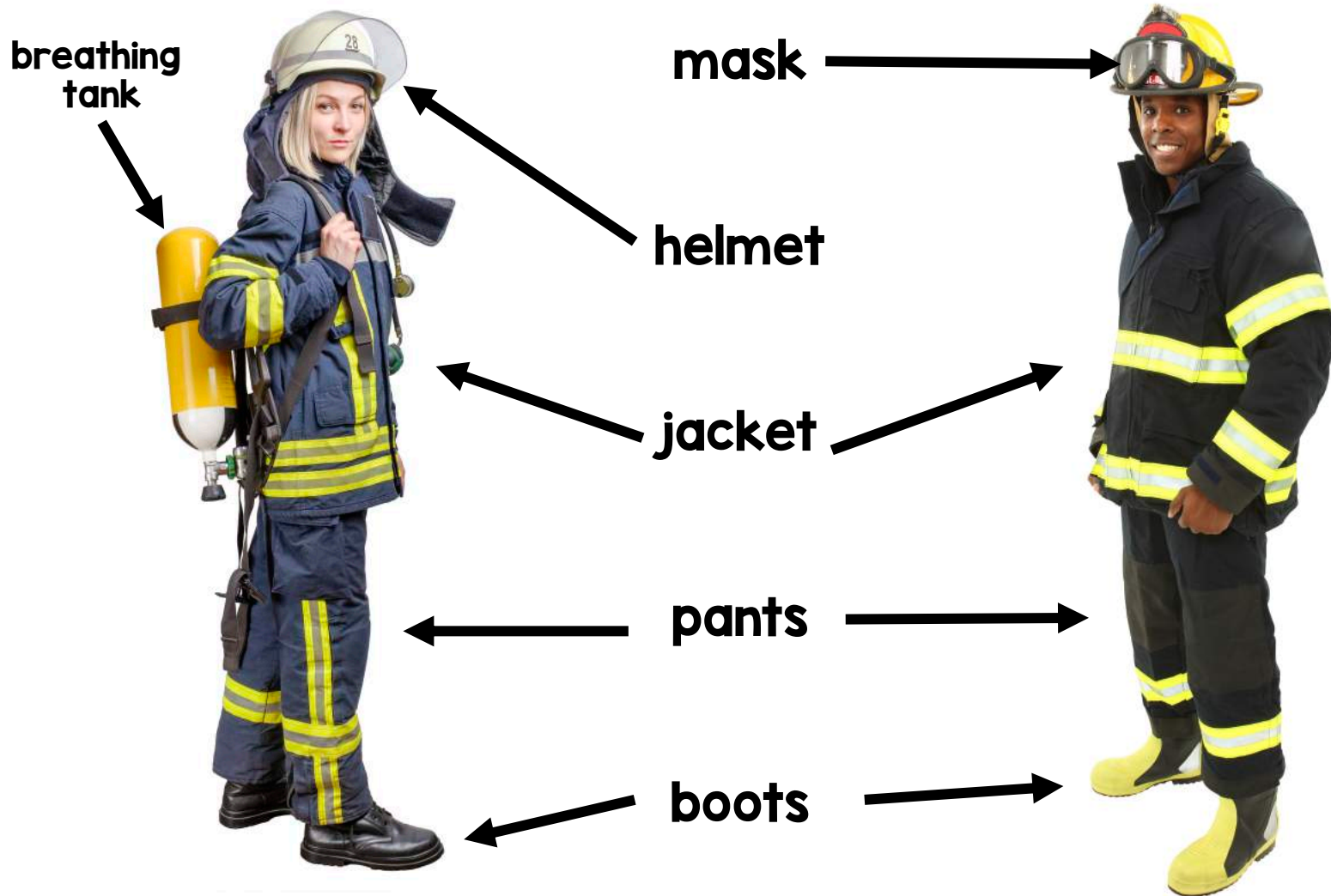

Firefighters wear a lot of gear to keep them safe from fire and smoke.



Firefighters use a mask to help them breathe while fighting fires with a lot of smoke.



Firefighters use tools such as fire extinguishers and hoses to put out fires.

I can label the parts of a firefighter.

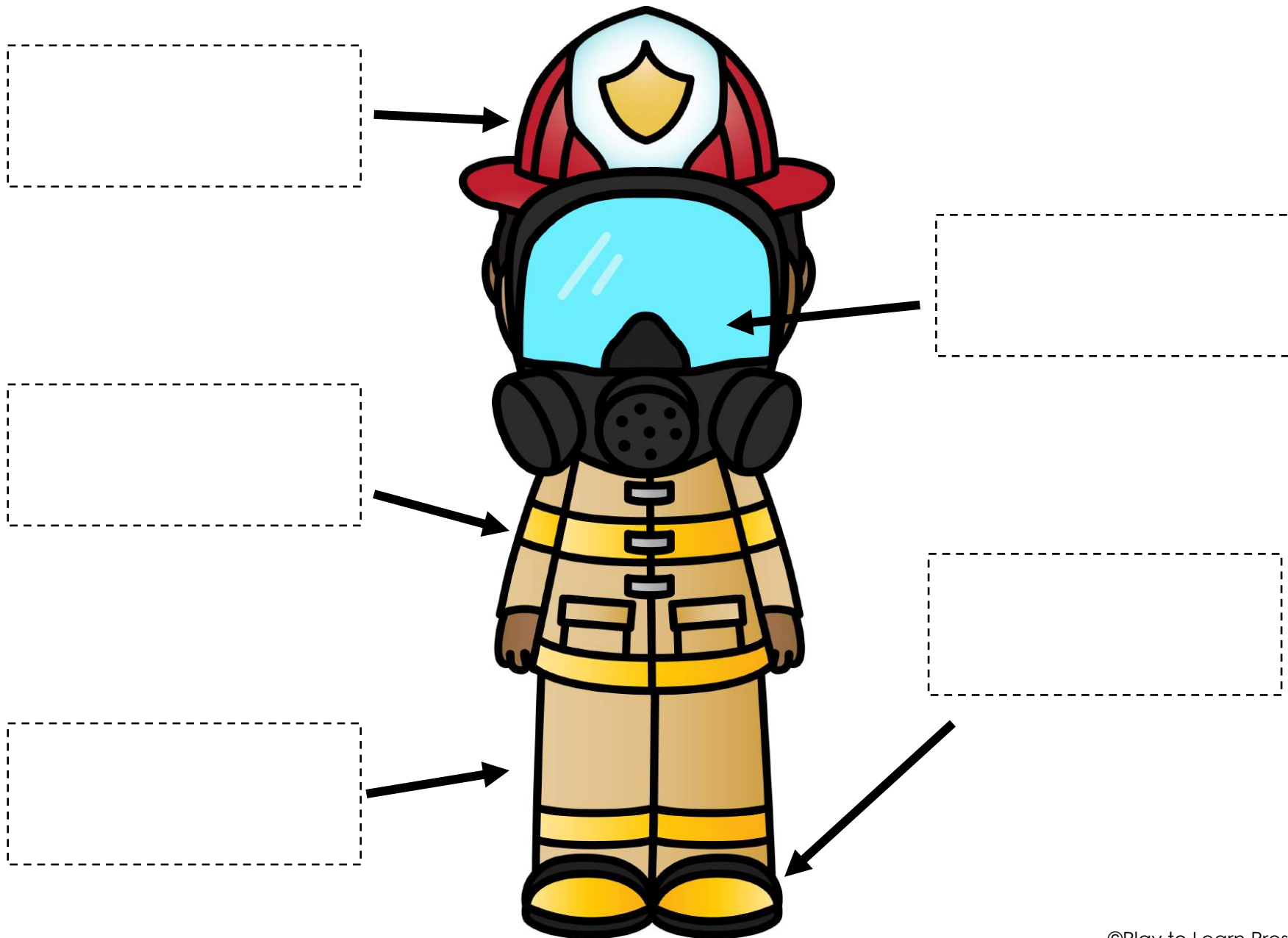

I can label the parts of a firefighter.

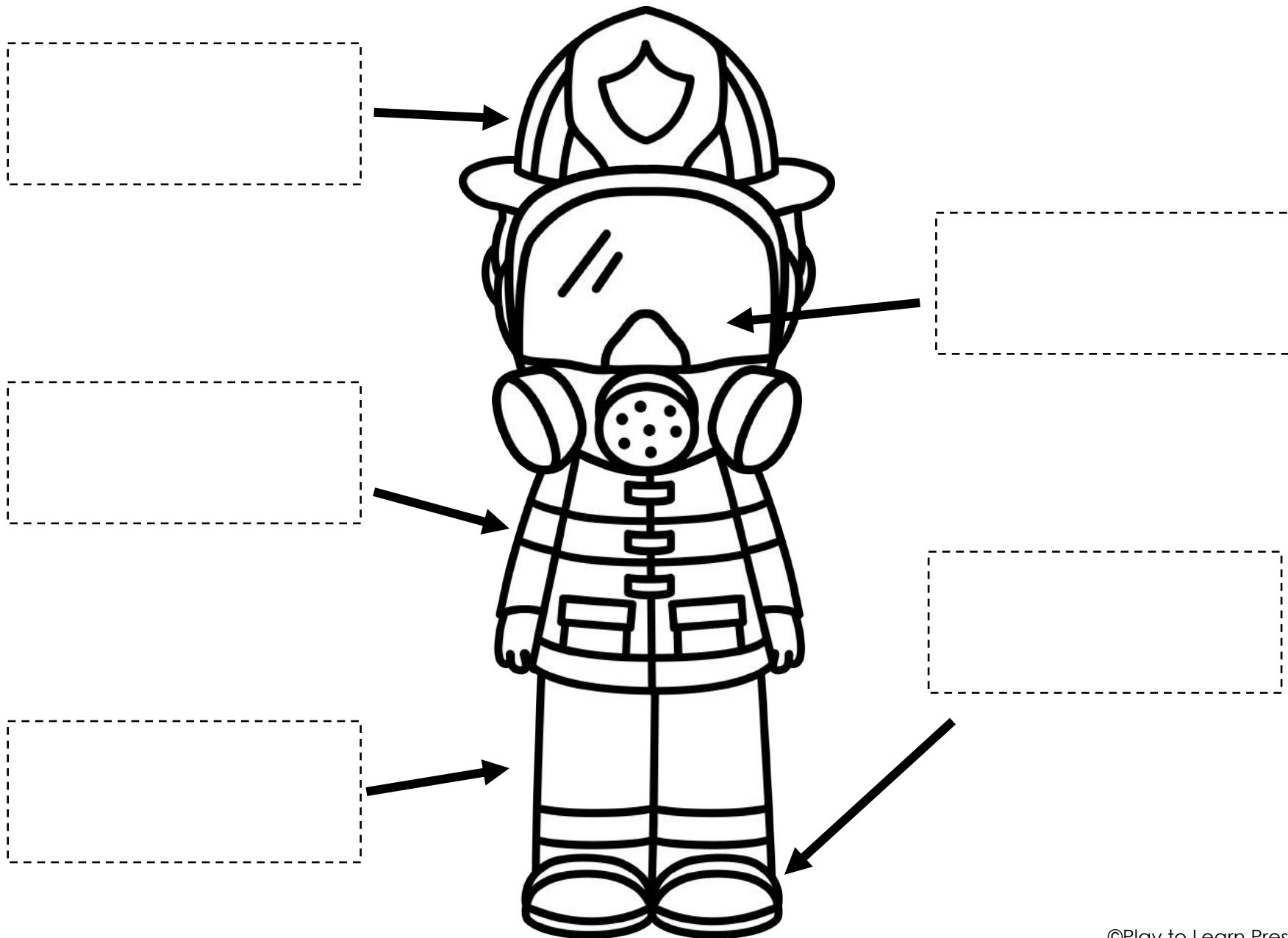

Use these cards to label the firefighter.

helmet

helmet

helmet

helmet

jacket

jacket

jacket

jacket

pants

pants

pants

pants

mask

mask

mask

mask

boots

boots

boots

boots

Where's the Hose?

Firefighter, firefighter,
Where's the hose?



Pick a number.
Let's see what you chose.

Where's the Hose?

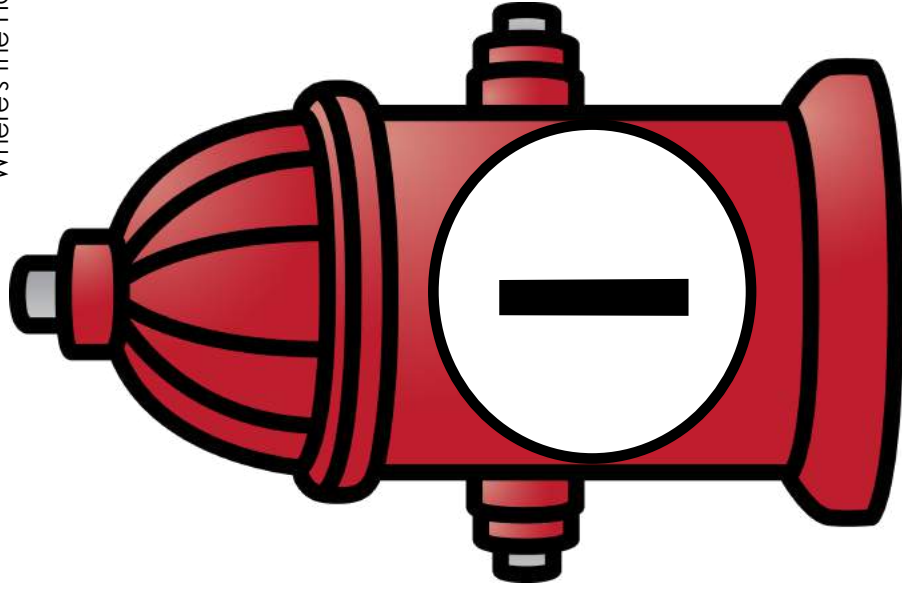

Where's the Hose?

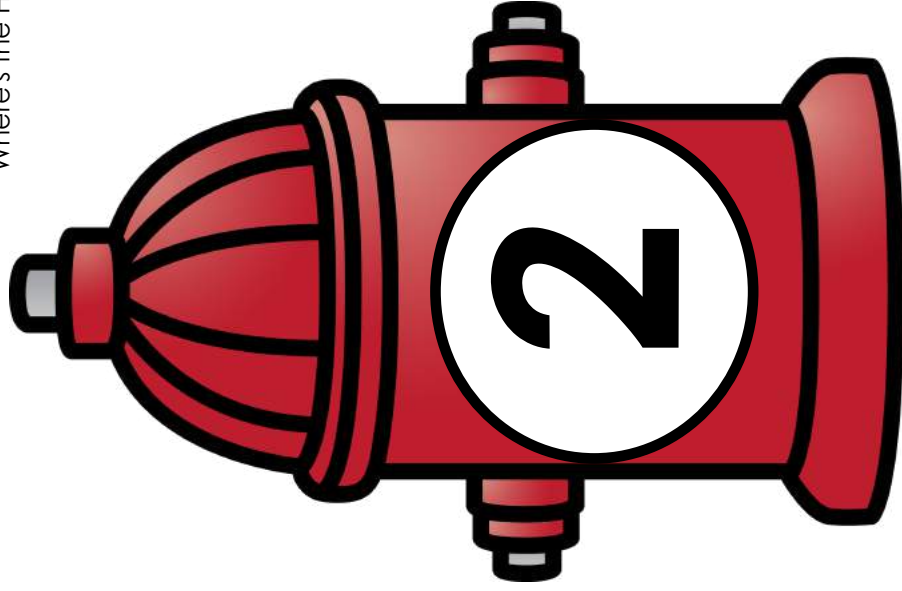

Where's the Hose?

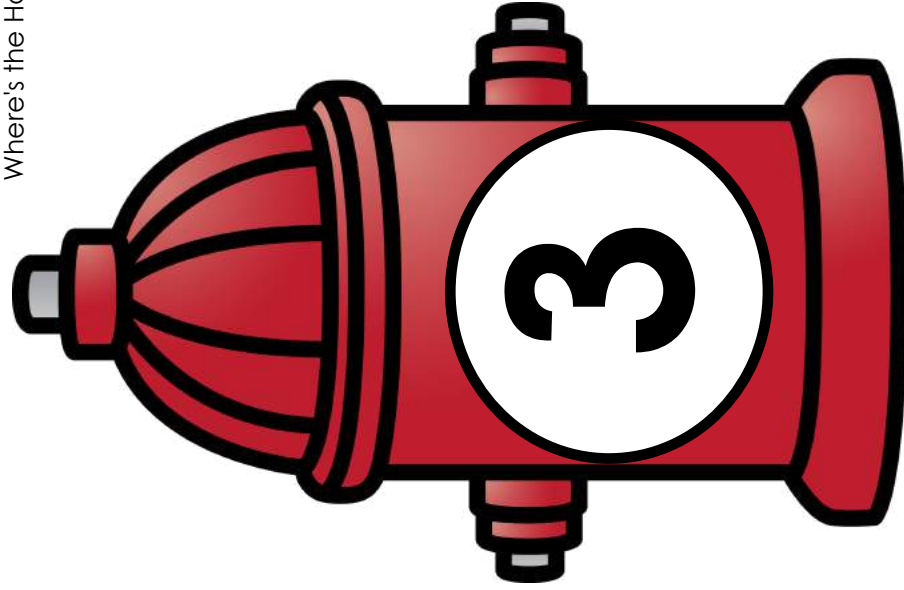

Where's the Hose?

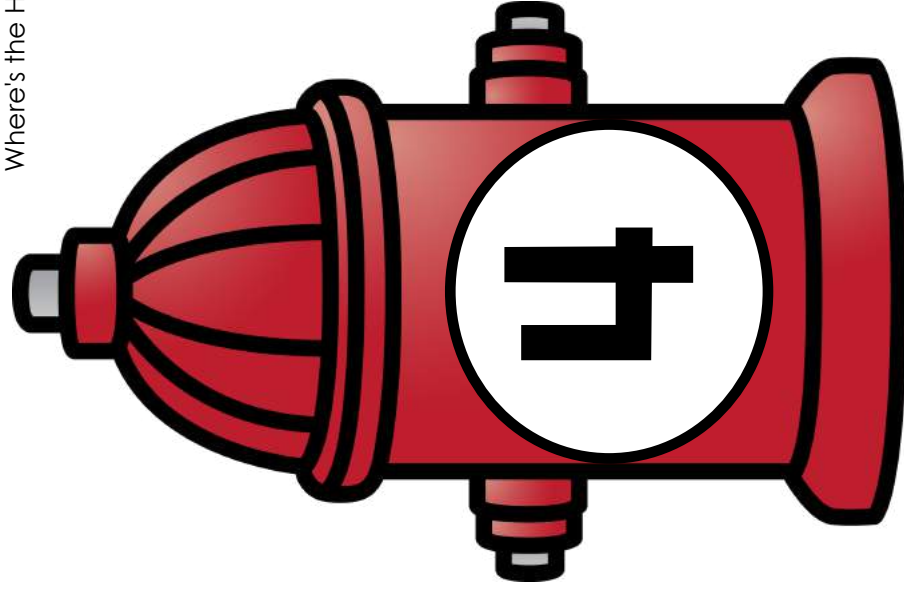

Where's the hose?

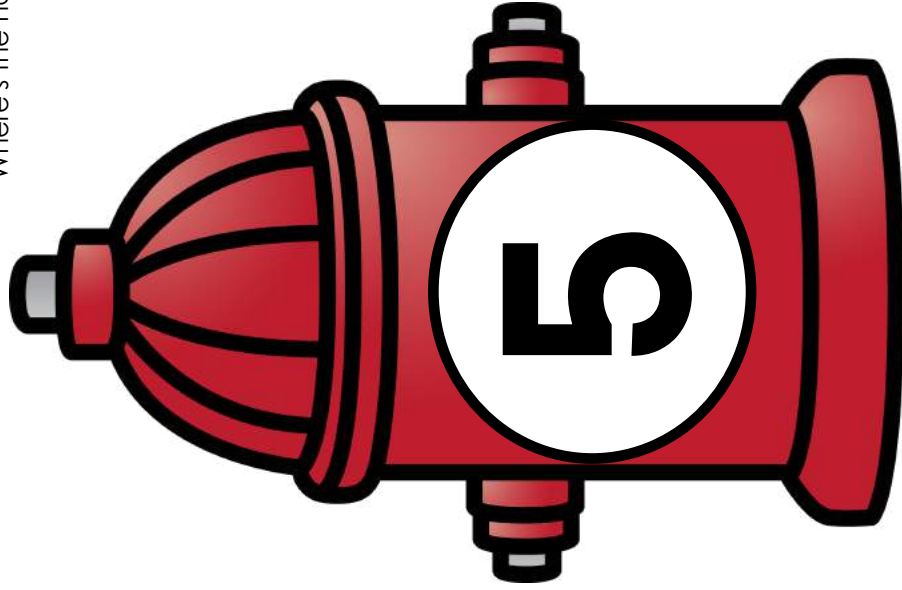

Where's the hose?

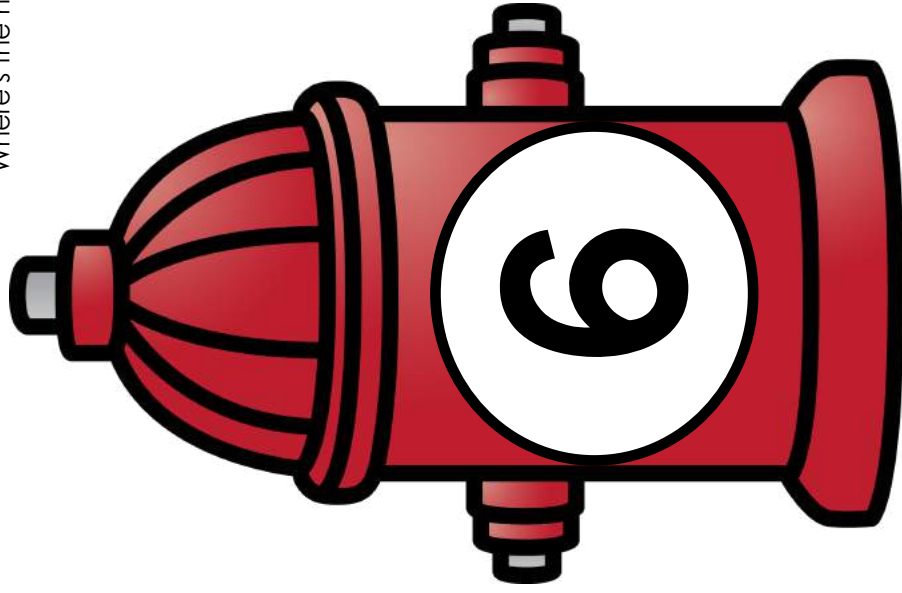

Where's the hose?

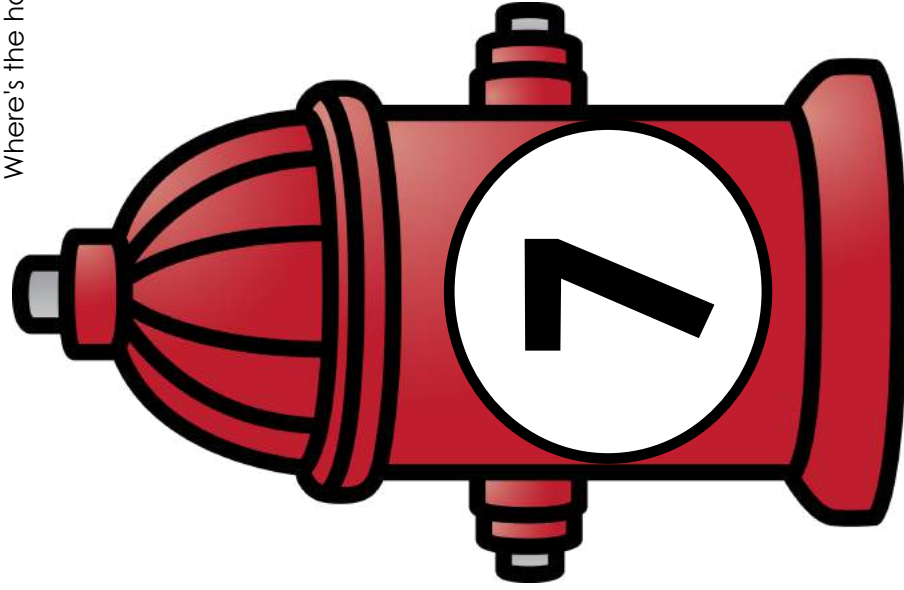

Where's the hose?

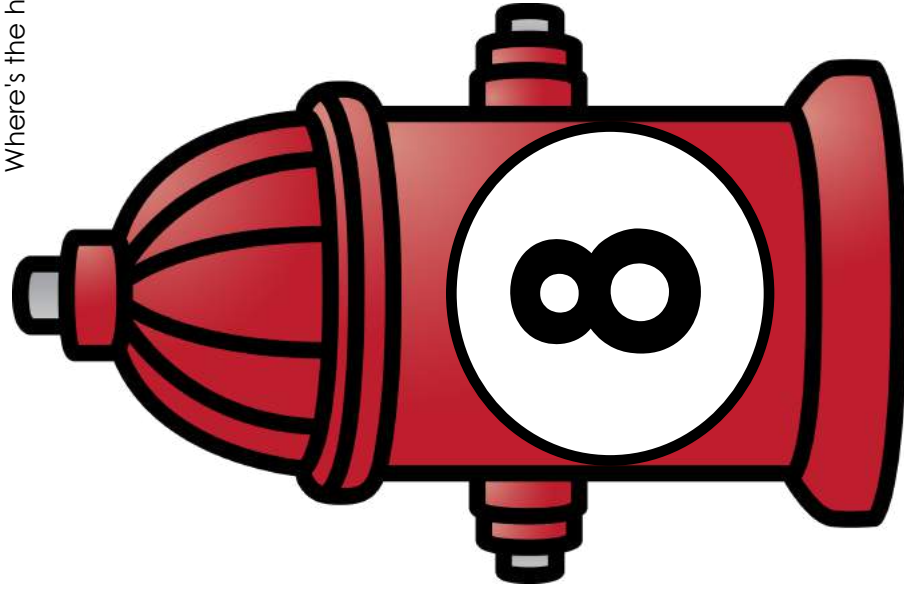

Where's the hose?

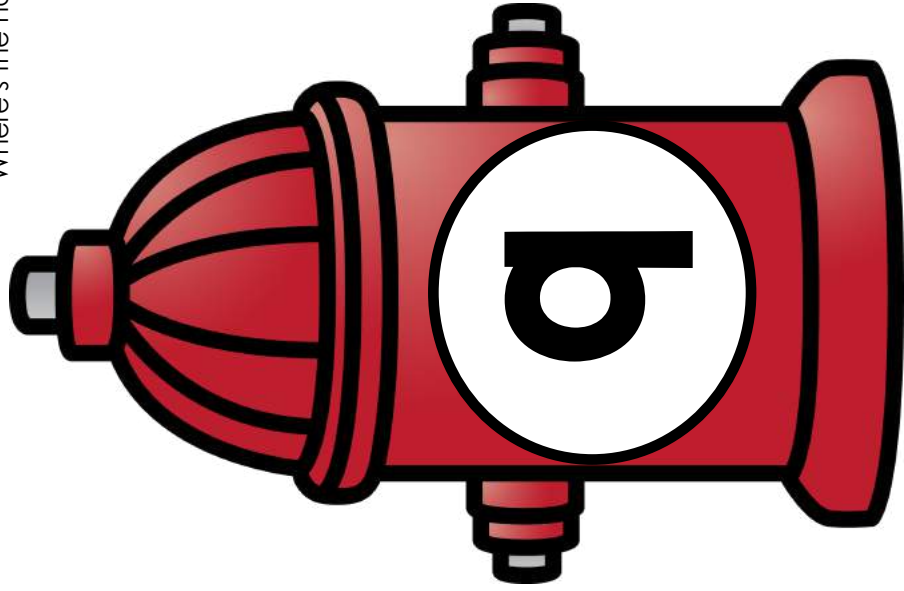

Where's the hose?

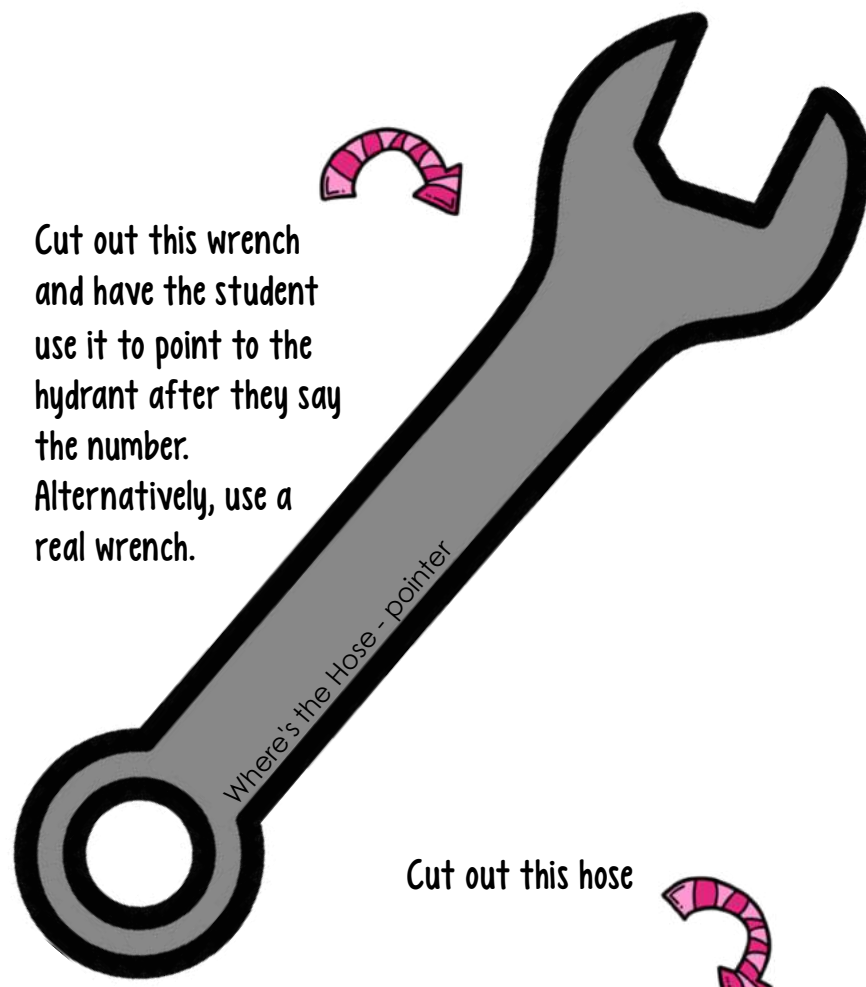
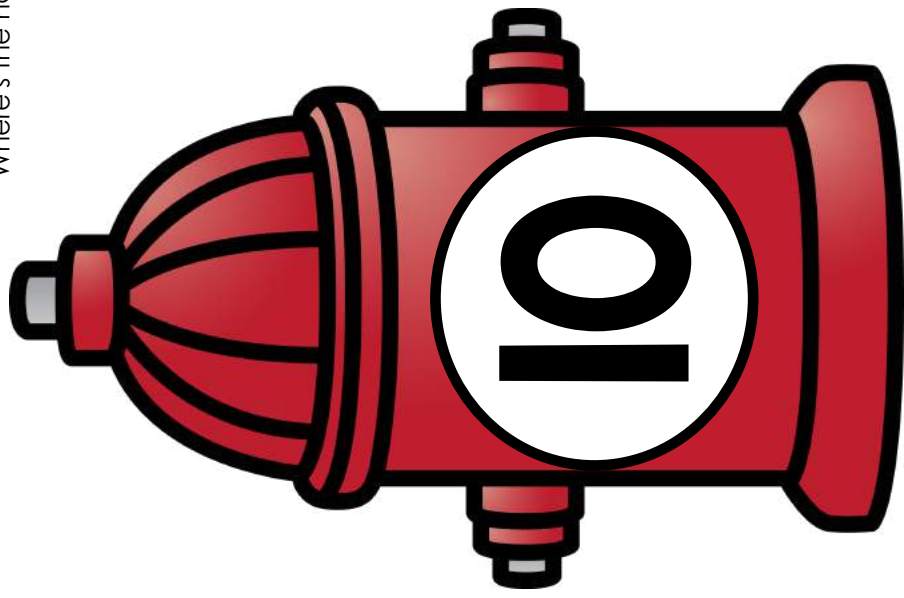

Cut out this wrench and have the student use it to point to the hydrant after they say the number. Alternatively, use a real wrench.

Cut out this hose

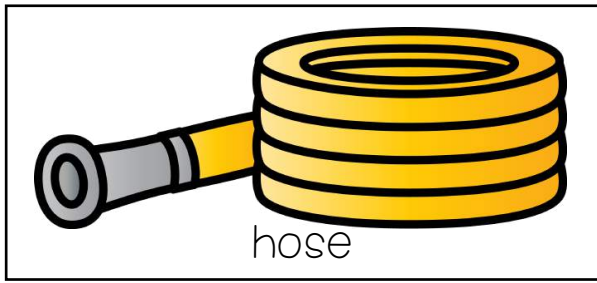

Stop, Drop, and Roll

Crawl Under Smoke

Day 3
lesson
plans

Show the students the safest way to respond to smoke in the room by dropping down and crawling to safety. If clothes catch on fire, teach them to stop, drop, and roll.

Objectives:

- Students will demonstrate basic locomotor skills.
- The students will express themselves using words and sentences.

Activities:

1. Look at the picture. Practice crawling with the students. Talk about “stop, drop, and roll” if clothes catch on fire.
2. Play a version of freeze dance with the fire safety spinner wheel. Play some music, spin the wheel and the act out the motion until the music stops. Assembly directions included on spinner page.
3. Play the Grid game.

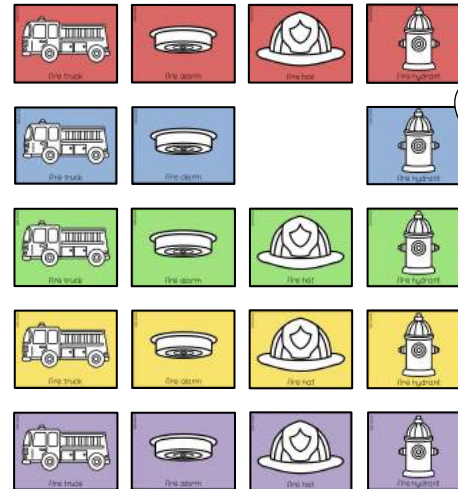
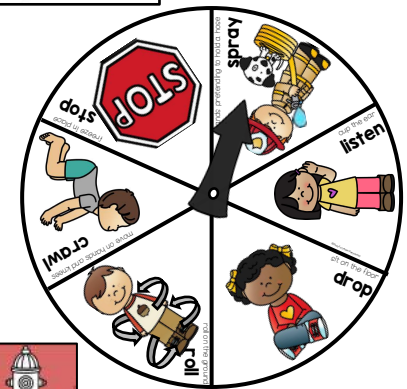

Which one is missing?

To Play:

1. Copy template page onto 5 different colors of paper.
2. Create a grid where each column has the same item, and each row is the same color. Discuss the pattern and relationship of the cards.
3. Students close their eyes while the teacher removes 1 card.
4. Students use their knowledge of patterns to determine which card (color and picture) is missing.

Extension Idea: Use chalk to draw flames on the ground outside or on paper. Fill a water bottle and squirt the flames until they disappear.



**If you see smoke, tell an adult
and crawl to safety.**

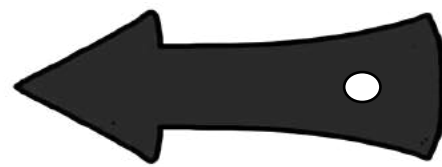
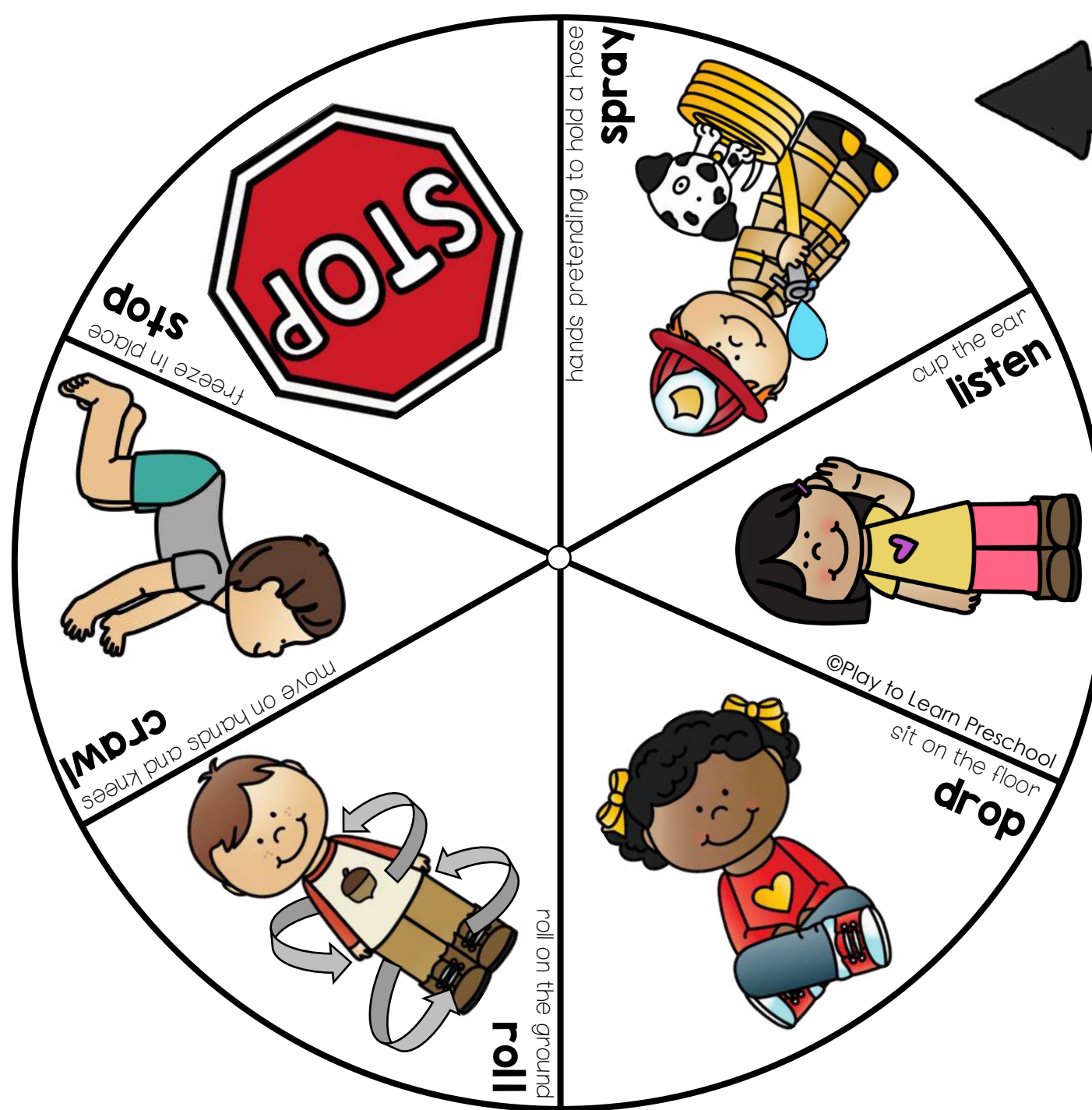

Print the spinner on heavy cardstock or back to cardboard. Make and assemble the "action spinner." Open up a paper clip, push one end through the arrow and then the spinner. Fold the end of the paperclip down the back and secure with tape. Twist the other end to ensure the arrow does not fall off. (see diagram below)

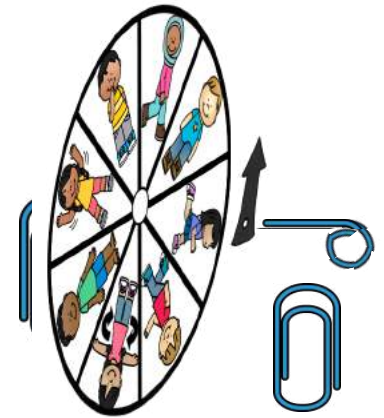

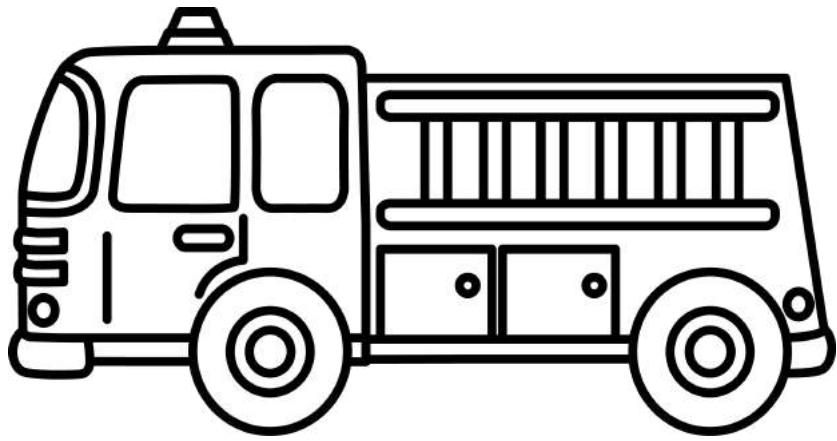

fire truck

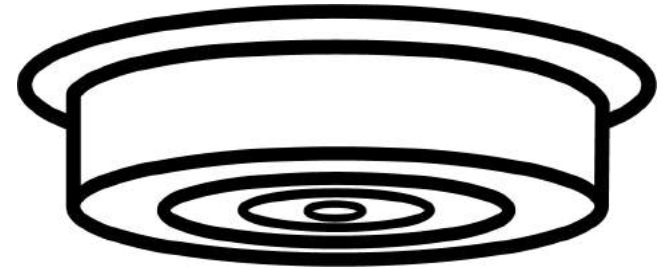

fire alarm

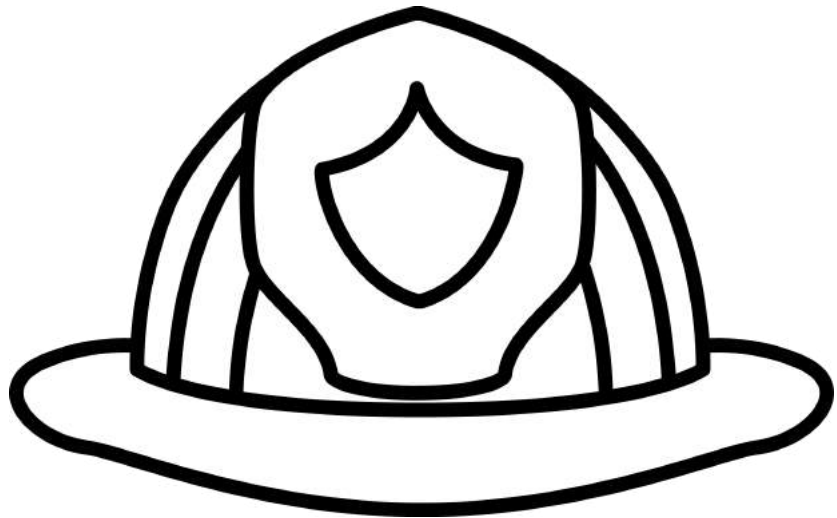

fire hat

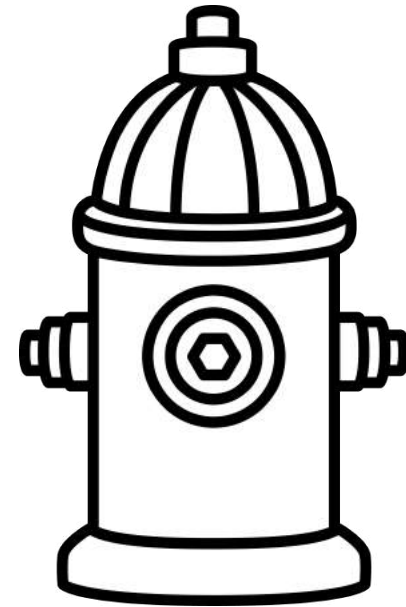

fire hydrant

Tell a Grown-Up

Staying Safe

Day 4
lesson
plans

It is important for young learners to understand what to do if they see something dangerous. Identify items that are dangerous then, tell an adult.

Objectives:

- The students will notice similarities and differences and ask questions.
- The students will sort pictures by property.
- The students will demonstrate basic locomotor skills.

Activities:

1. Show the real pictures to the students and discuss when it is important to “tell a grown-up” if they see something dangerous.
2. Play the “Safe/Not Safe” pocket chart game. Instruct the students to give two thumbs up if the item is safe or two thumbs down if it is not safe.
3. Play the game “Captain Says” like “Simon Says.” Show an action card and have the students act out how they would use/wear that item.



Extension Idea: Print out the “Safe/Not Safe” black and white sheet. Students cut out the pieces, then sort them into the right box. Or send the sheet home for the student to do with their family.

Name _____

Put out the pieces at the bottom of the page. Glue them into the correct column.

Safe	Not Safe
oven toothbrush crayon fire book shovel table gift pillow	





**Firefighters use hoses to put out fires.
If you see fire, tell a grown-up right away!**



knife



sewing needle



hot grill



matches



medicine

**If you see any of these things,
do NOT touch them and tell a grown-up!**

These things



are safe.

These things

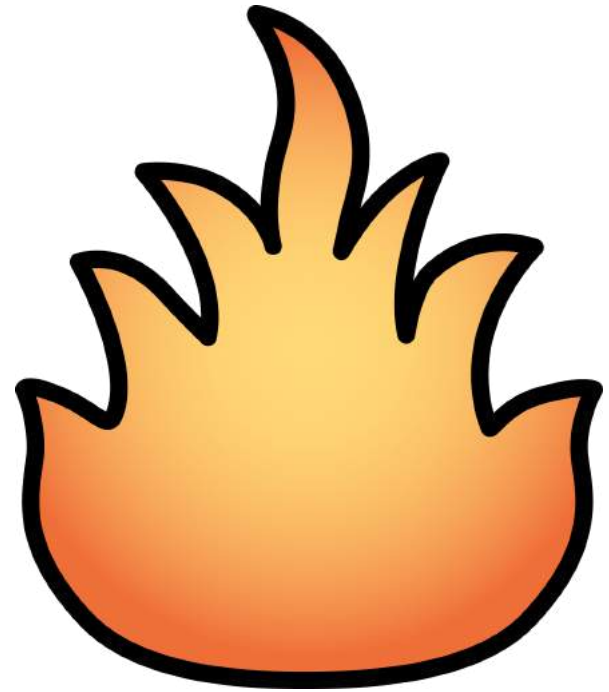

are **NOT** safe.

(Tell a grown-up)

Safe/Not safe sort

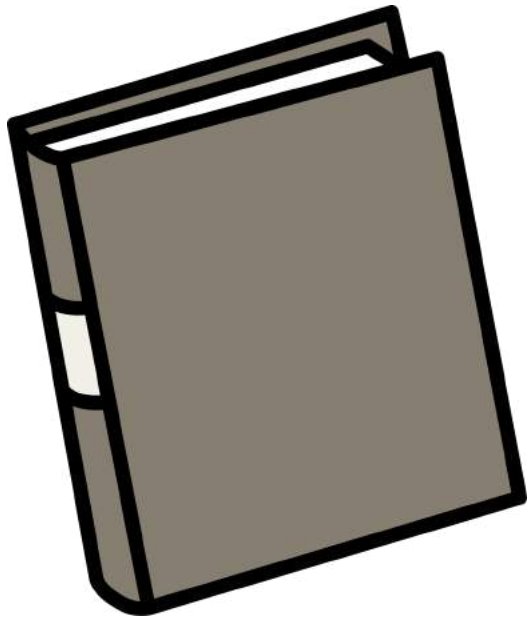

book

Safe/Not safe sort

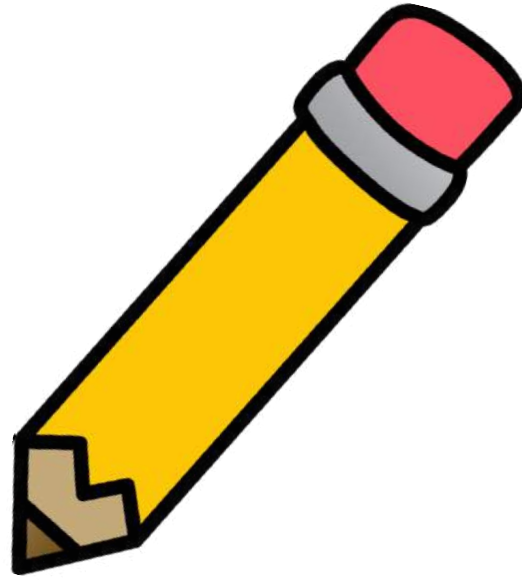

pencil

Safe/Not safe sort

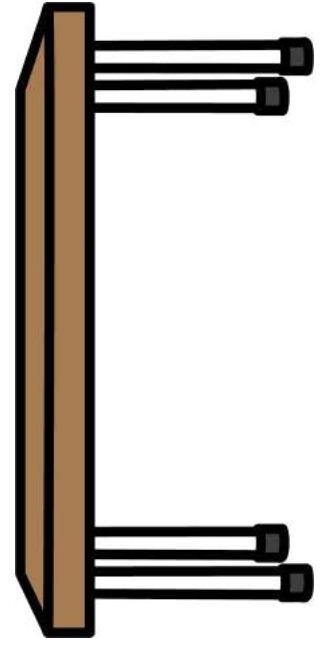

table

Safe/Not safe sort



crayon

Safe/Not safe sort

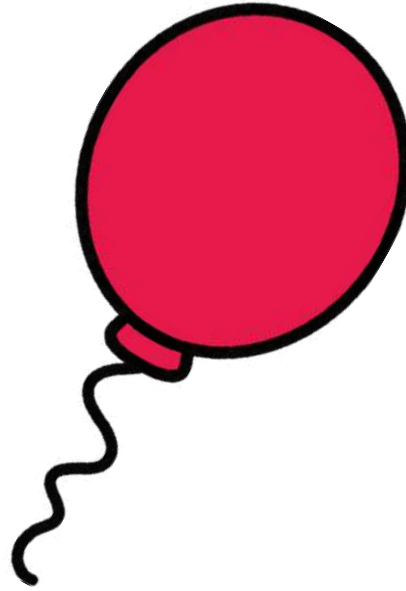

balloon

Safe/Not safe sort

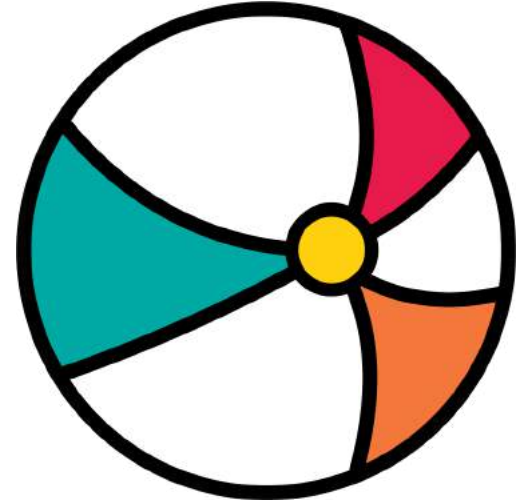

ball

Safe/Not safe sort

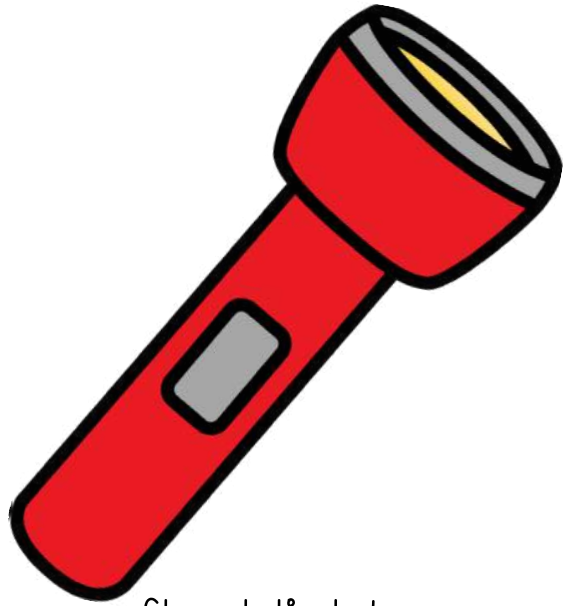

flashlight

Safe/Not safe sort

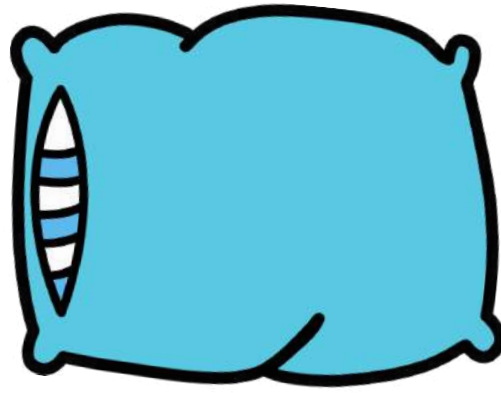

pillow

Safe/Not safe sort



socks

Safe/Not safe sort

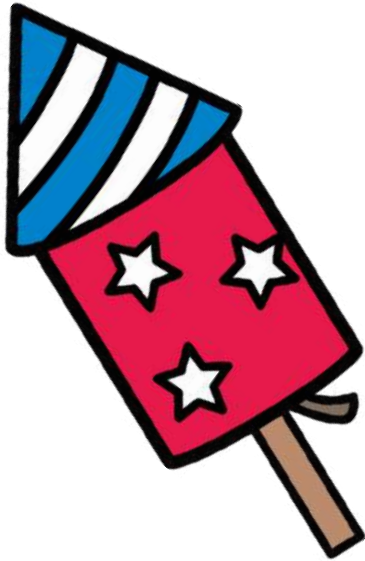

fireworks

Safe/Not safe sort

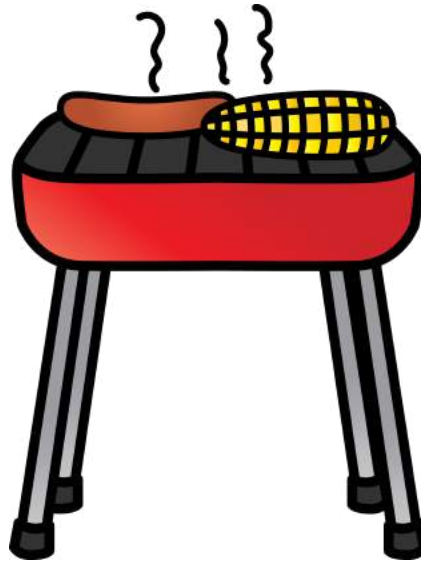

grill

Safe/Not safe sort

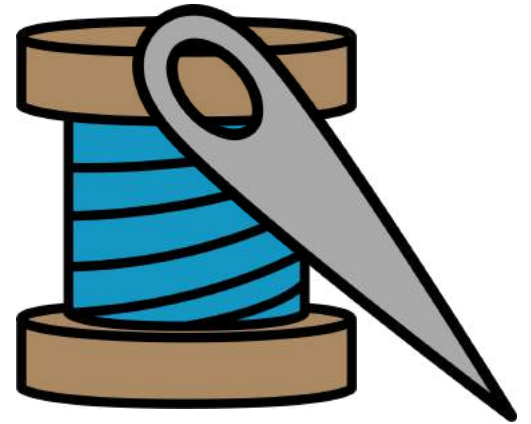

needle

Safe/Not safe sort



medicine

Safe/Not safe sort

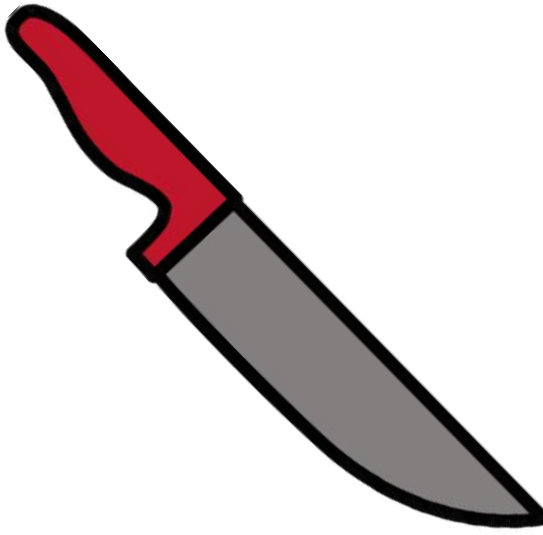

knife

Safe/Not safe sort



stove

Safe/Not safe sort



matches

Safe/Not safe sort

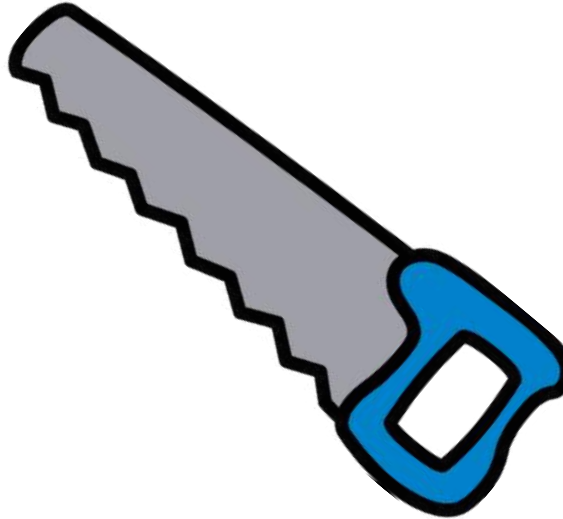

saw

Safe/Not safe sort

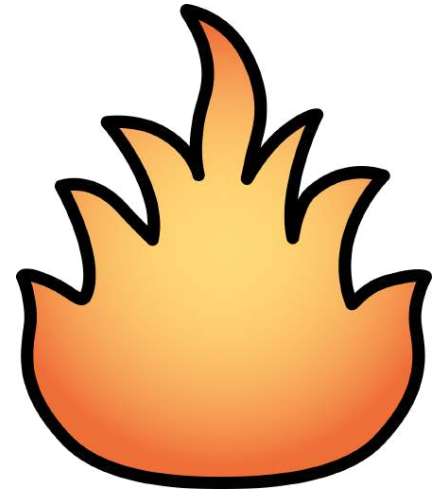

fire

Captain Says

Play like "Simon Says"

Captain says,
Stomp around in your fire boots.

(stomp around the circle)

Captain says,
Pull on your fire jacket.
(pretend to pull on a jacket)

Repeat with verses:

Pull up your fire pants.
Put your helmet on your head.
Cover your face with the mask.
Spray the fire with a hose.
Climb up the ladder with
your hands and feet.
Drive the fire truck.

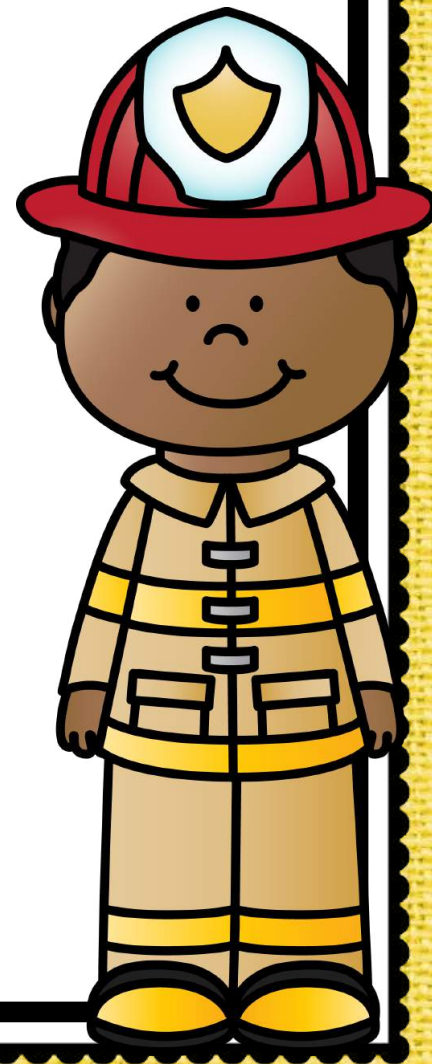



Stomp around in your boots



Pull on your jacket

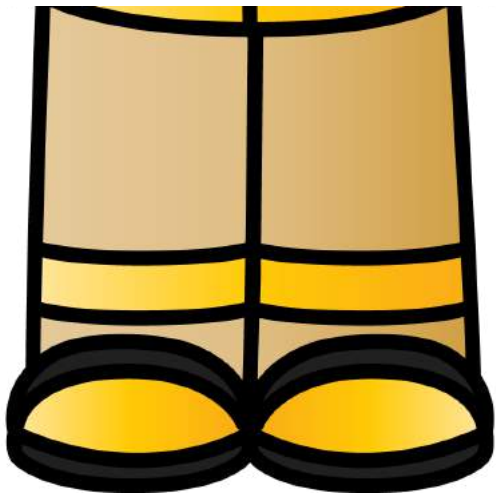

Pull on your pants



Put your helmet on your head



Cover your face with the mask

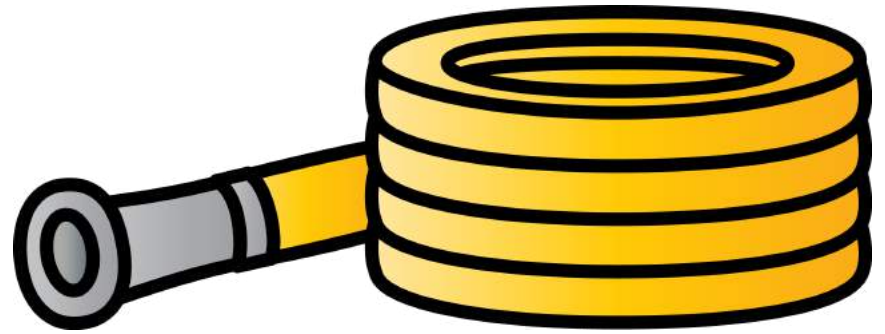

Spray the fire with a hose

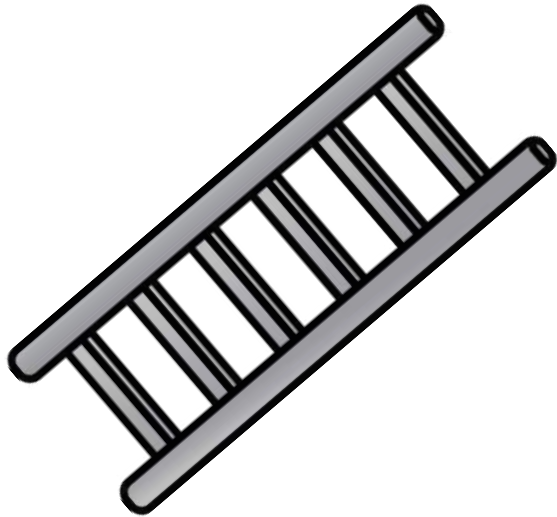

Climb the ladder with your hands and feet



Drive the fire truck, beep-beep

Name _____



Cut out the pieces at the bottom of the page.

Glue them to the correct column.

Safe 

Not Safe 



oven



teddy bear

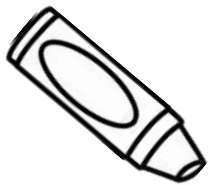

crayon

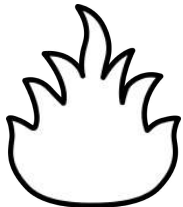

fire



book



saw



grill

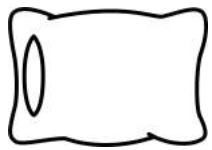

pillow

Conclusion

What We Know

Day 5
lesson
plans

To conclude the unit, ask the students to describe what they have learned about fire safety.

Objectives:

- The students will actively participate in conversations.
- The students will interact and participate in circle time.

Activities:

1. Invite the students to list the things they have learned about fire safety. Write their ideas on index cards or the hydrant cards provided.
2. Read the riddle while the students practice their active listening skills. They guess the answer to the question and then double check the answer card inside the bag. Please adjust the riddle answers to the guidelines of your organization.



Extension Idea: Make a memory tray with 4-6 small fire safety-themed toys. (helmet, firetruck, tiny hose, toy firefighter, boots) Show the students the tray and then have them close their eyes while you take one toy away. Have them guess which toy is missing.



What we have learned about fire safety.



What I know about fire safety.

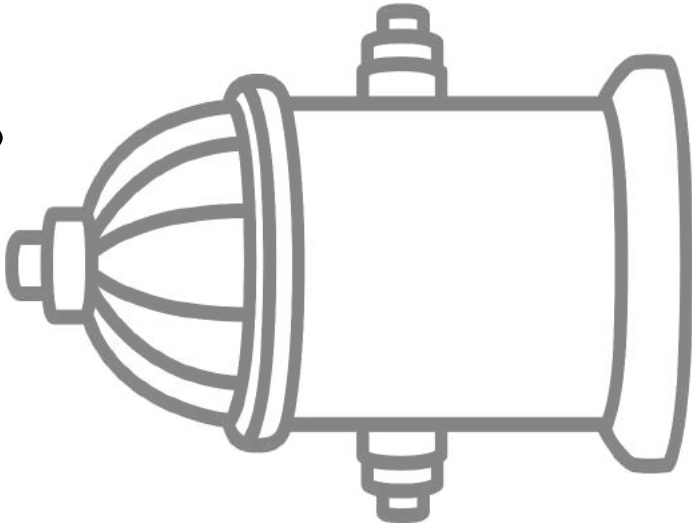

Name: _____

What I know about fire safety.

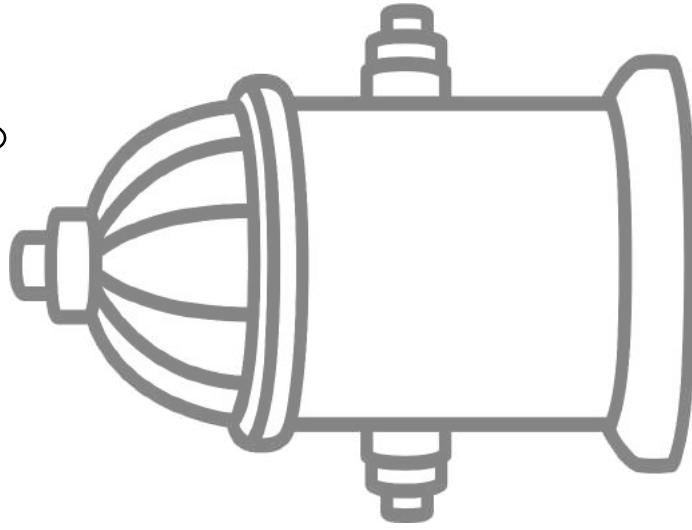

Name: _____

What I know about
fire safety:

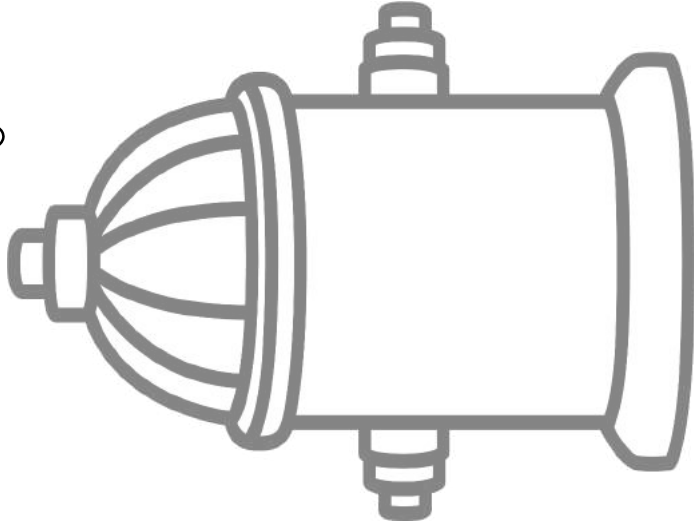

Name: _____

What I know about
fire safety:

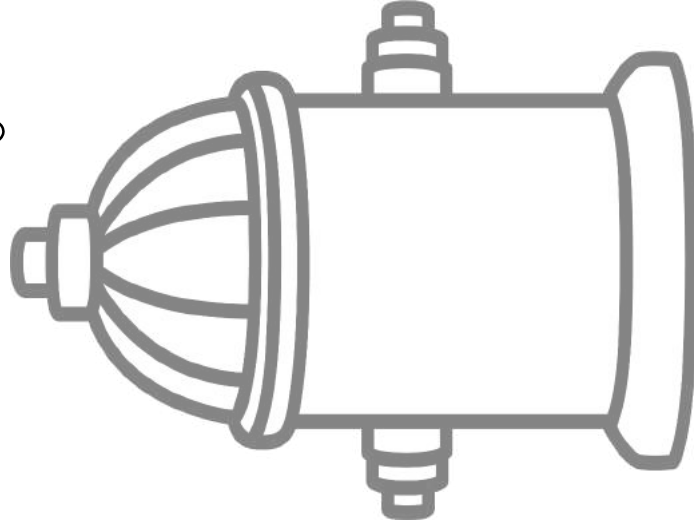

Name: _____

What I know about
fire safety:

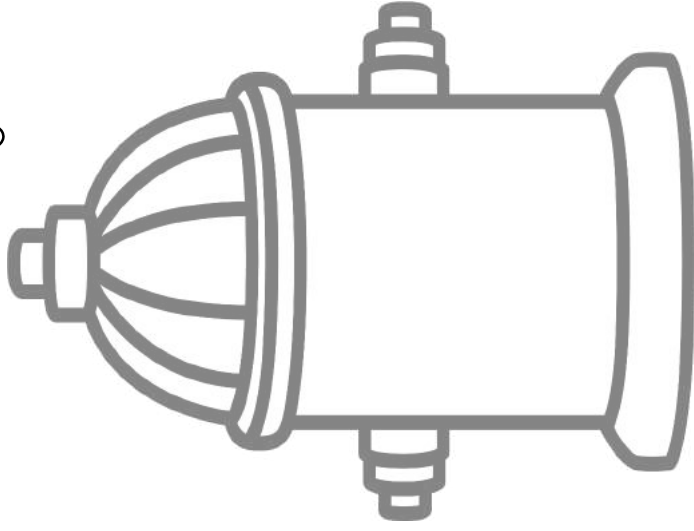

Name: _____

What I know about
fire safety:

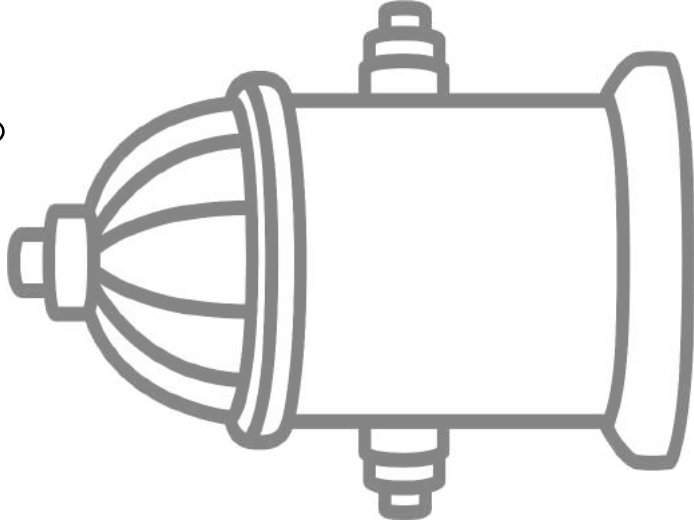

Name: _____

Riddle #1

I walk into a room and I see smoke up near the ceiling. What should I do?

Answer: tell a grown-up, get down, and crawl out.

Riddle #2

When we hear the fire alarm, what should we do?

Answer: stop what we are doing and quietly line up at the door.

Riddle #3

During a fire drill when we are standing in our meeting spot outside, should we be quiet, or talking?

Answer: quiet

Riddle #4

How should we be standing when we are outside in our meeting spot during a fire alarm?

Answer: standing tall in a straight line

Riddle #5

What do firefighters wear on their head to protect them from falling debris?

Answer: helmet

Riddle #6

What do firefighters wear on their face to protect them from smoke and fire?

Answer: mask

Riddle #7

What does a firefighter use to spray the water on the fire?

Answer: hose

Riddle #8

What should I do if I see matches?

Answer: tell a grown-up

Riddle #1

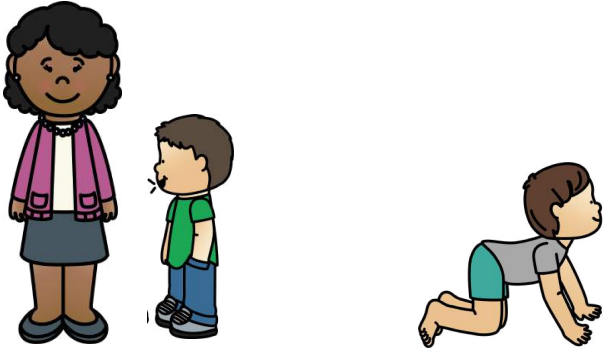
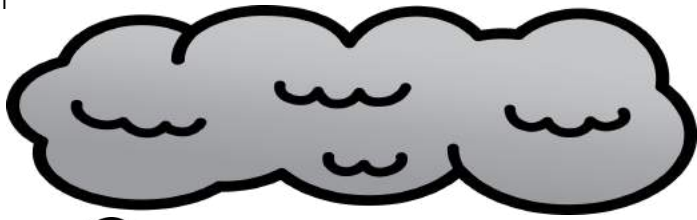

Tell a grown-up, get down, and
crawl out.

Riddle #2

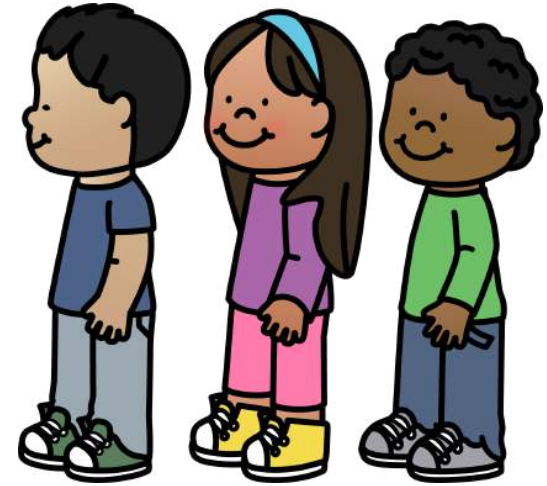

Stop what we are doing and
quietly line up.

Riddle #3

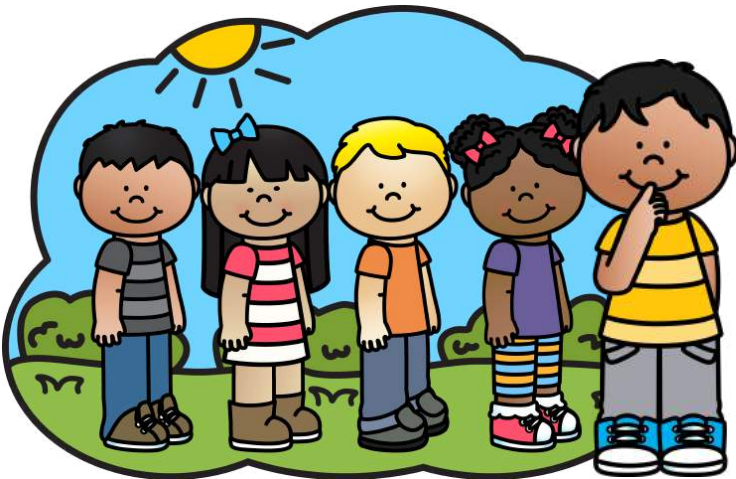

quiet

Riddle #4

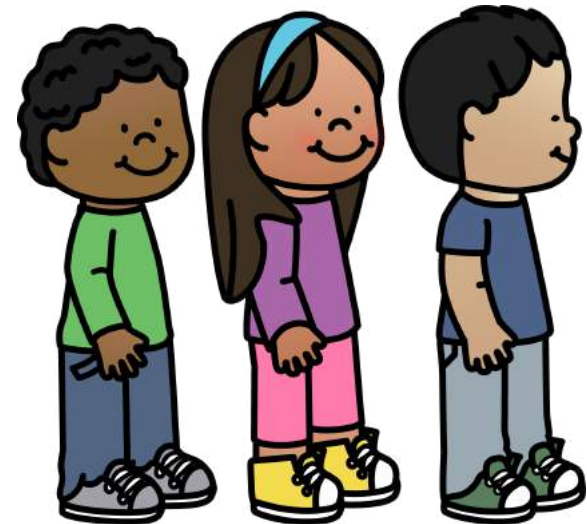

In a line

Riddle #5



helmet

Riddle #6



mask

Riddle #7

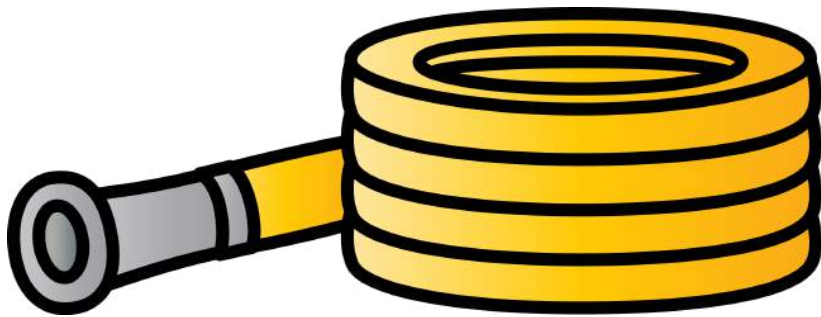

hose

Riddle #8

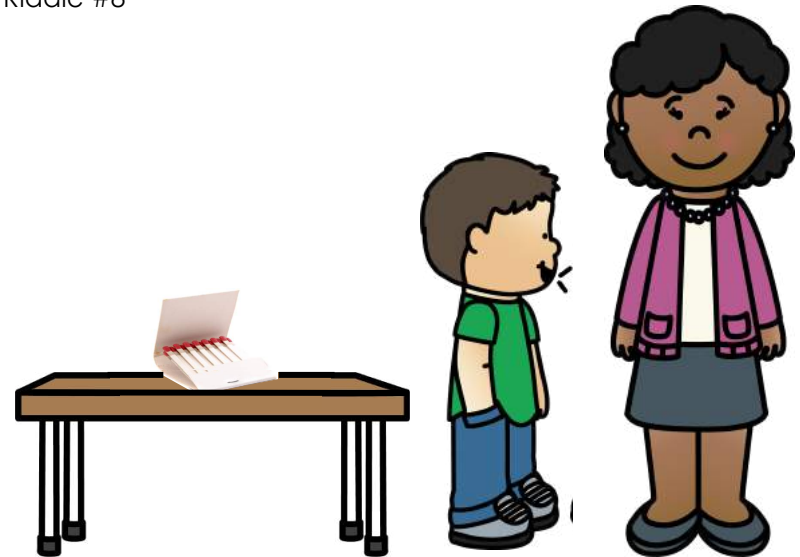

Tell a grown-up

Centers

- Line Tracing
- Writing Practice
- Counting
- Count & Clip Cards
- Concentration
- Book List (recommendations)

Line Tracing

Literacy Center

Objective: The students will understand the purpose of writing.
Preparation: Print and laminate these tracing cards. Another option is to place them inside a plastic sleeve. Provide dry erase markers. (Glue a pom-pom onto the lid of the marker for the students to use as an eraser!)

Count and Clip Cards

Math Center

Objective: Students will practice one-to-one correspondence and number recognition to 12.
Preparation: Print the cards, mat, laminate and cut apart.
Procedure: Students count the pictures on each card and mark the correct answer with a clothes pin.

Counting

Math Center

File Folder Game

Objective: The students will count and recognize numbers.
Preparation: Copy the picture cards. Glue the large pictures (first 2 pages) inside a file folder. Cut and laminate the smaller pictures.
Procedure: Students will count and choose the correct number.

Counting

Writing Practice

Literacy Center

Students will write letters.
 Copy each page and place into a plastic sleeve (or print on cardstock).
 Students use a dry erase marker to trace the word.

Concentration

Working memory

Students will use visual discrimination (matching) skills to identify identical objects.
Preparation: Print the picture cards. Mat onto cardstock and/or laminate. Cut apart.
Procedure: Place cards facing down. Students take turns flipping over 2 cards at a time. If the cards match, the student gets to keep the pair. If not, they return them to the face-down position and try again.

Line Tracing

Objective: The students will understand the purpose of writing.

Preparation: Print and laminate these tracing cards. Another option is to place them inside a plastic sleeve. Provide dry erase markers. (Glue a pom-pom onto the lid of the marker for the students to use as an eraser!)

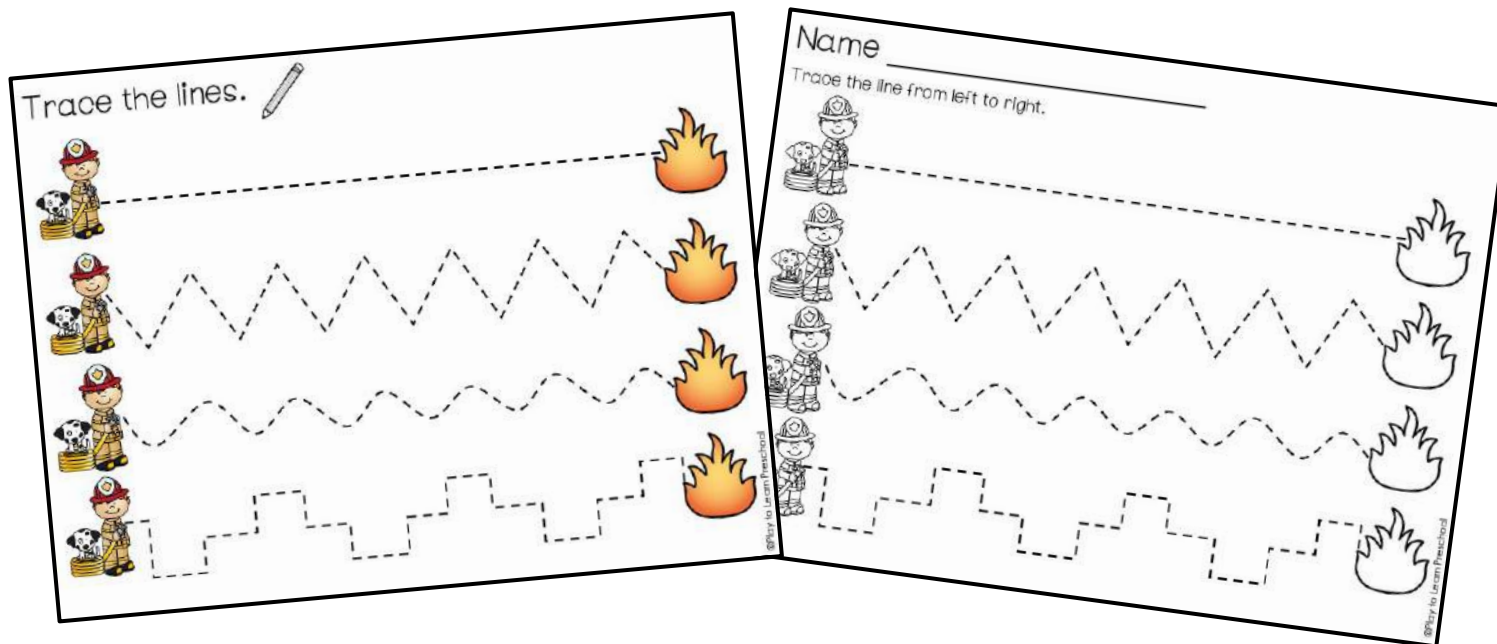

Procedure: The students will trace the dotted lines from left to right to practice fine motor skills.

Trace the lines.

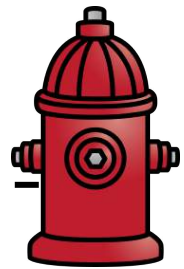
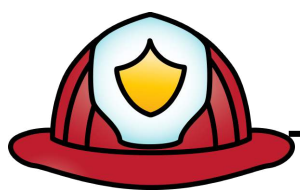
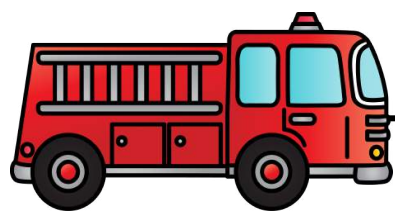

Name _____

Trace the line from left to right.

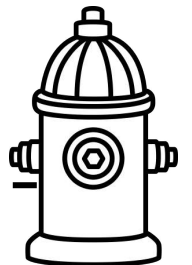
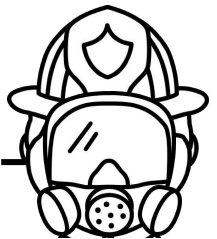
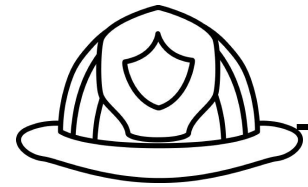
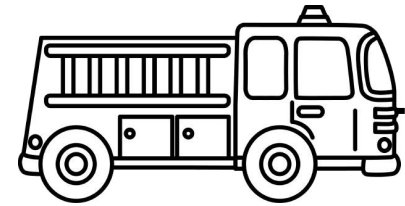

Trace the lines. 



Name _____

Trace the line from left to right.

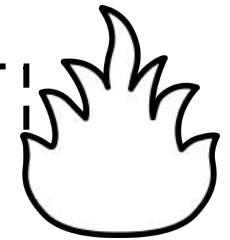
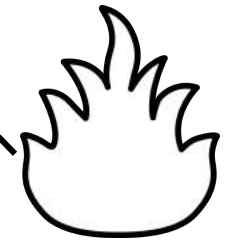
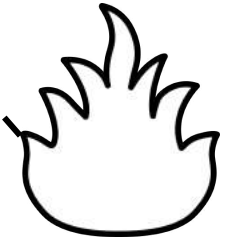
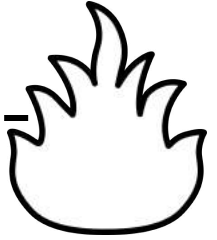

Trace the lines. 

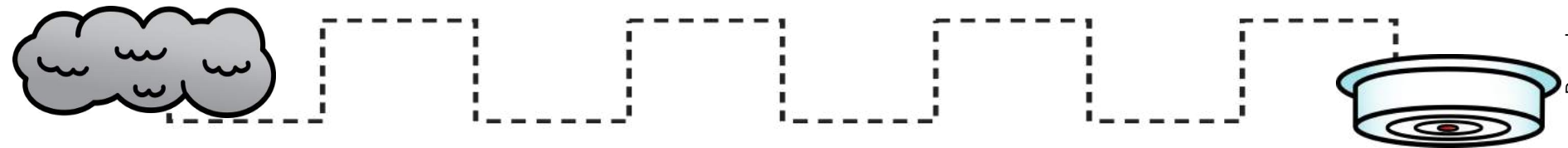
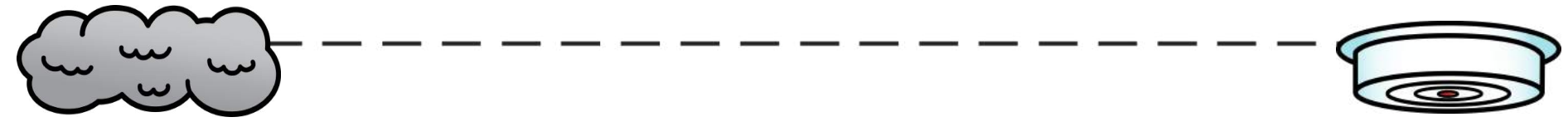

Name _____

Trace the line from left to right.

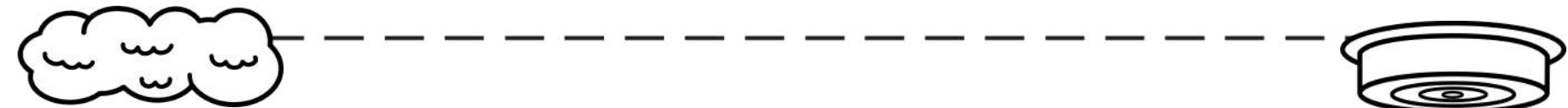

Writing Practice

Objective: The students will write letters.

Preparation: Copy each page and place it into a plastic sleeve (or print on cardstock and laminate).

Procedure: Students use a dry erase marker to trace the word.

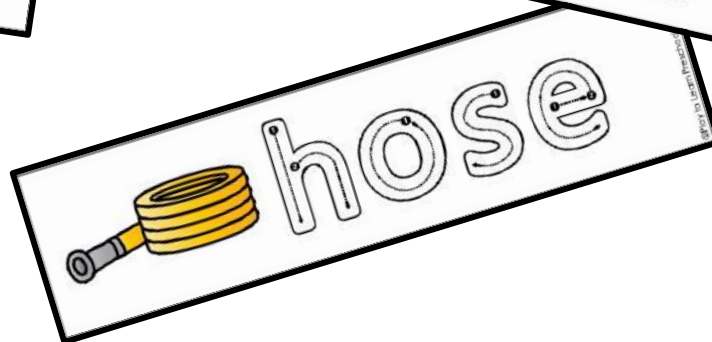
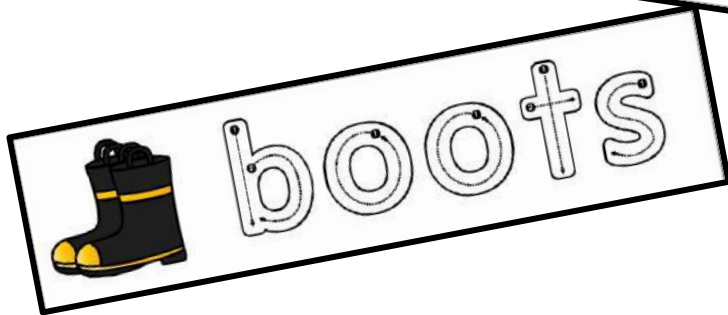
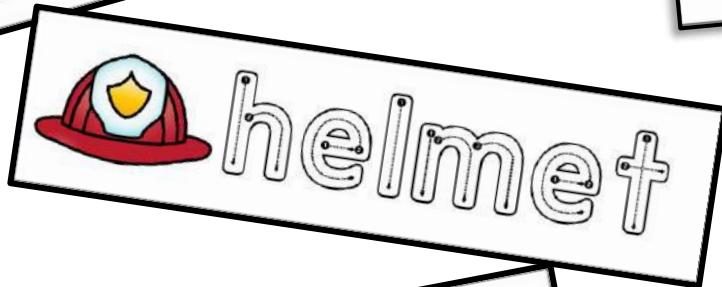
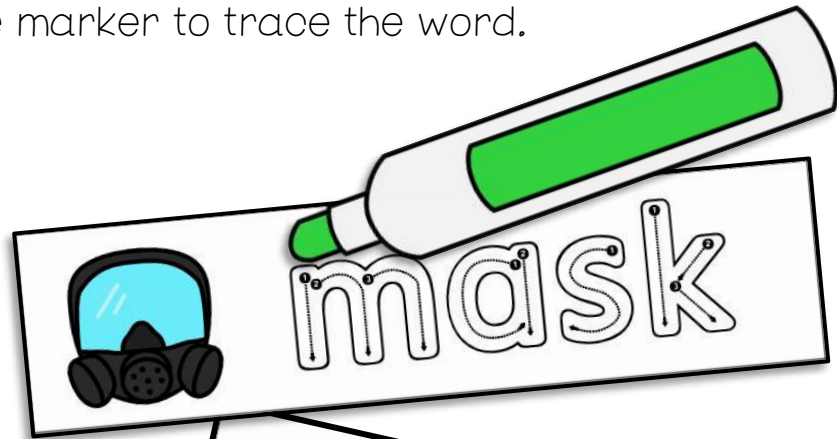
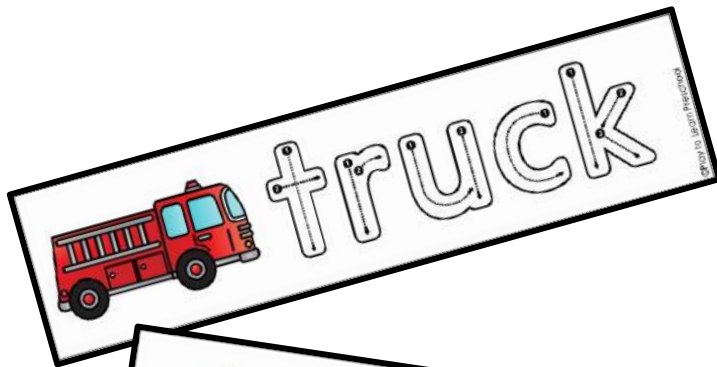



h e l m e t



b o o t s



t r u c k



m a s k



f i r e

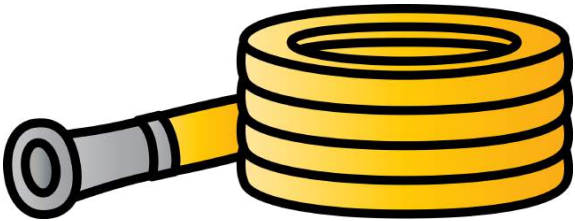

h o s e

Counting

File Folder Game

Objective: The students will count and recognize numbers.

Preparation: Copy the picture cards. Glue the large pictures (first 2 pages) inside a file folder. Cut and laminate the smaller pictures.

Procedure: Students will count and choose the correct number.

Counting

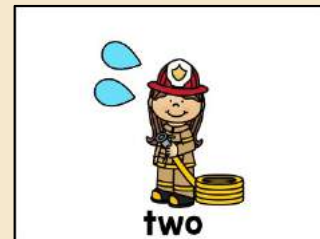

Counting

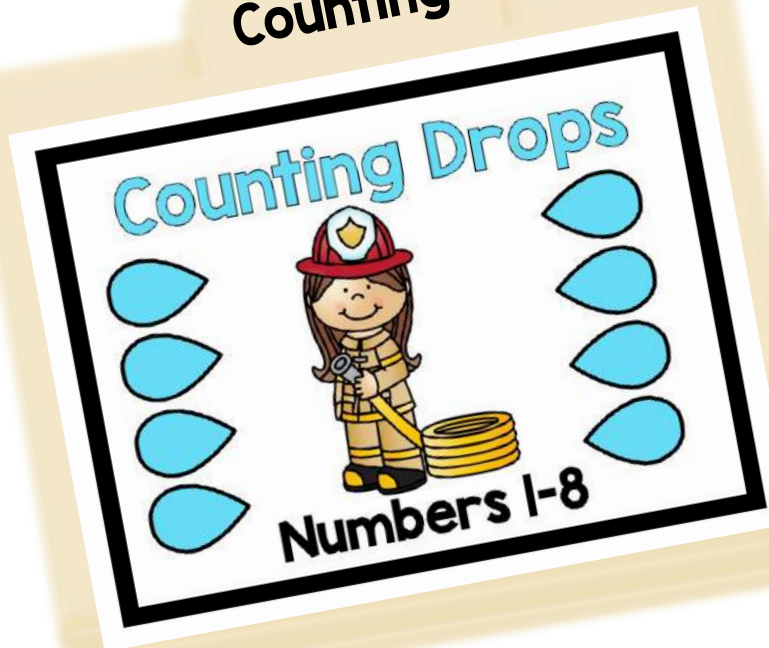

Counting Drops

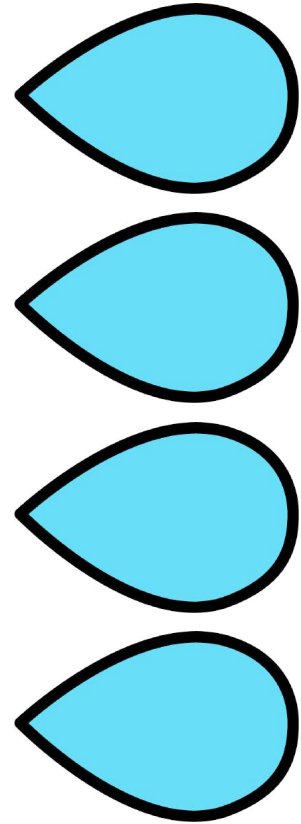
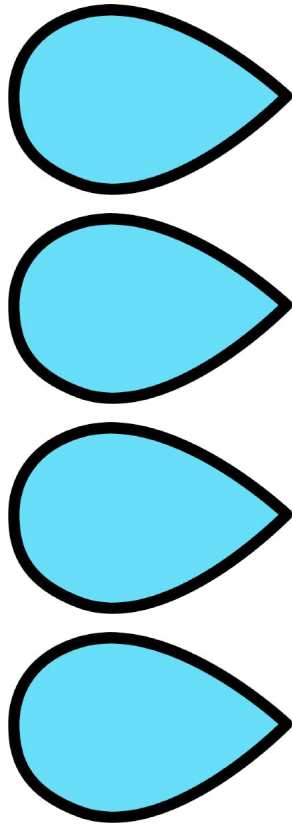

Numbers 1-8



one



two



three



four



five



six



seven



eight

Counting Drops

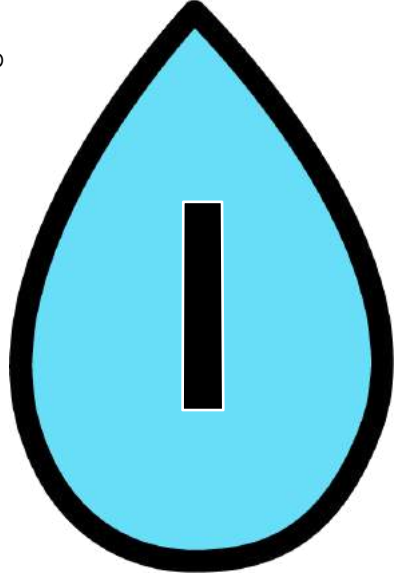

Counting Drops



Counting Drops



Counting Drops

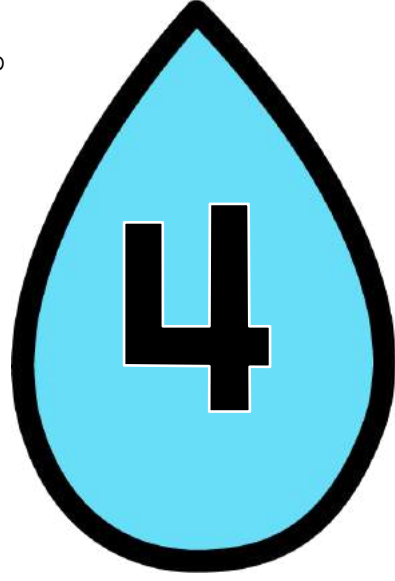

Counting Drops



Counting Drops



Counting Drops



Counting Drops



Count and Clip Cards

Objective: Students will practice one-to-one correspondence and number recognition to 12.

Preparation: Print the cards, mat, laminate, and cut them apart.

Procedure: Students count the pictures on each card and mark the correct answer with a clothespin.

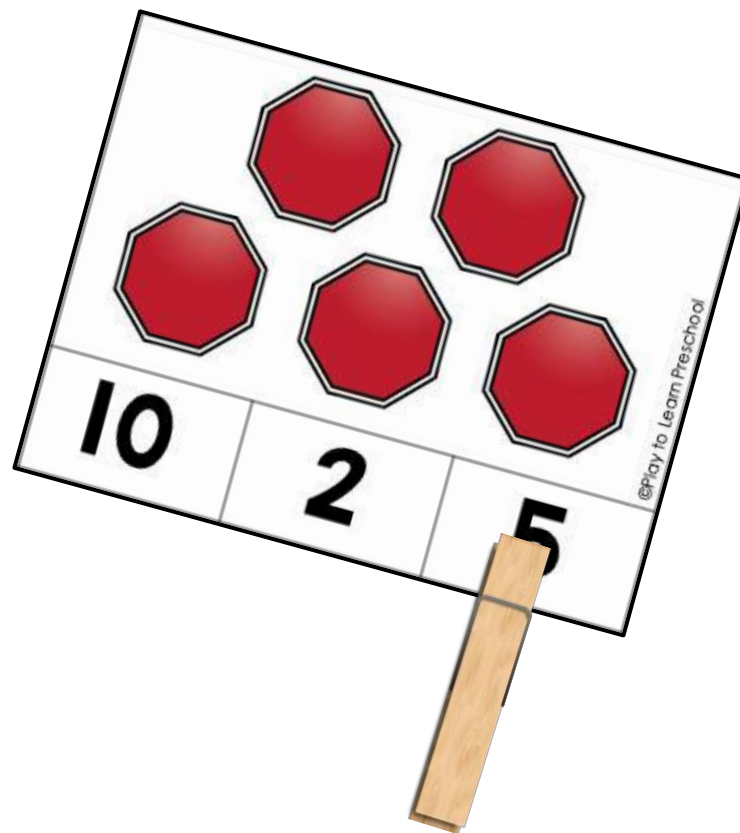
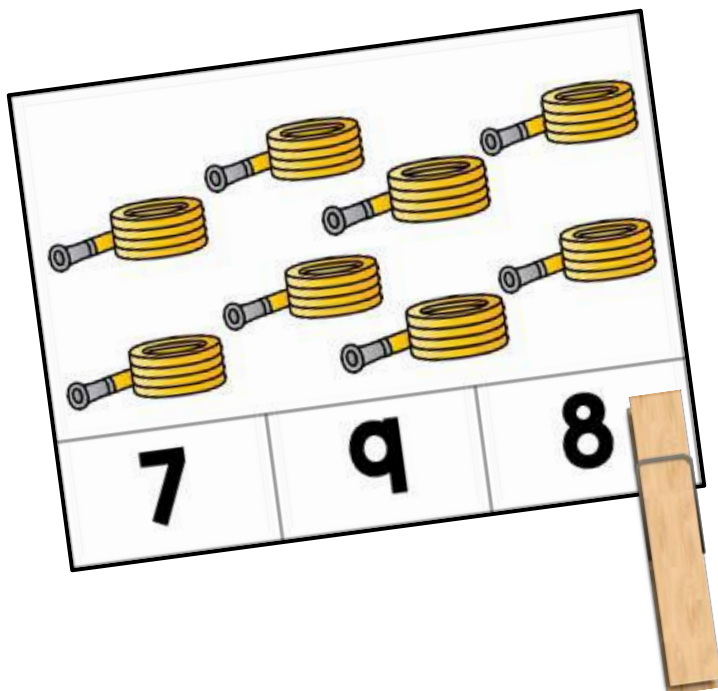

Helpful Hint:

For easy self-checking, put a sticker on the back that will match the clothes pin if the answer is correct.

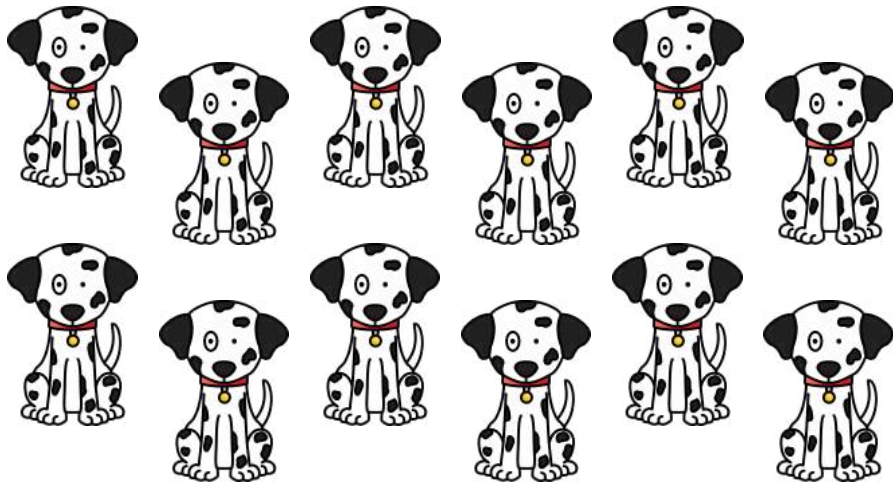

12

8

9



4

11

10



8

6

10

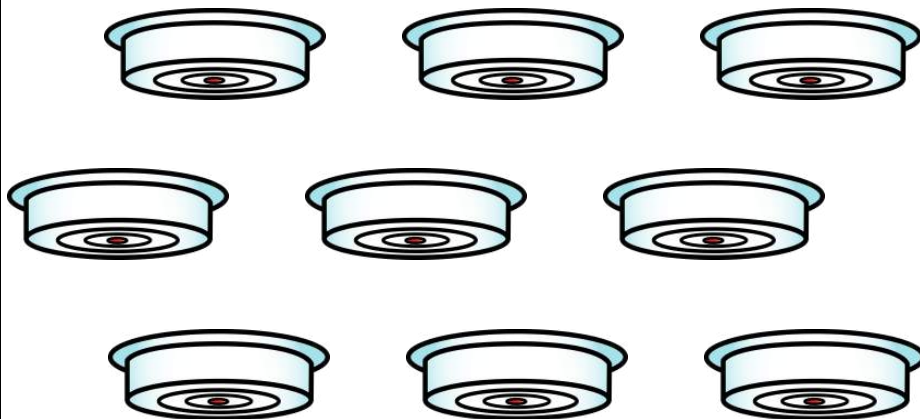

9

6

5

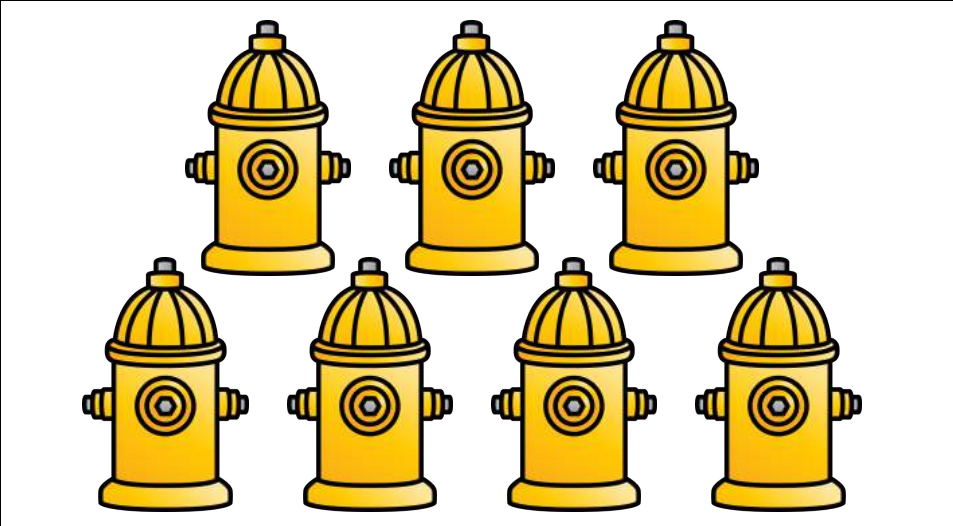
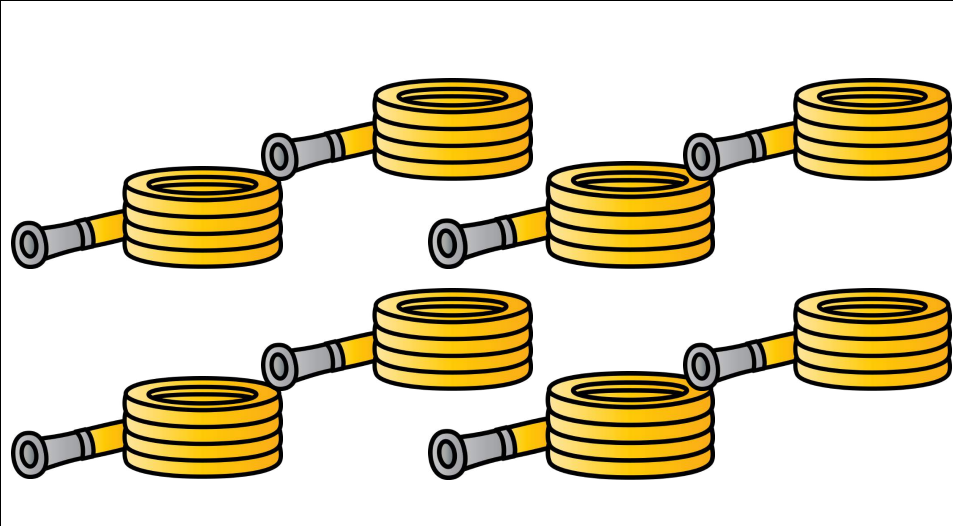

7

9

8

5

4

7

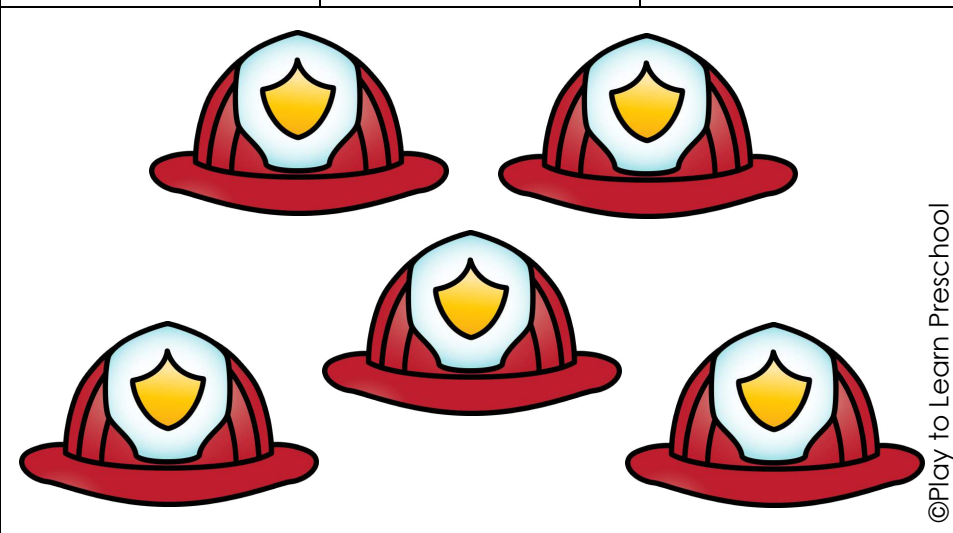
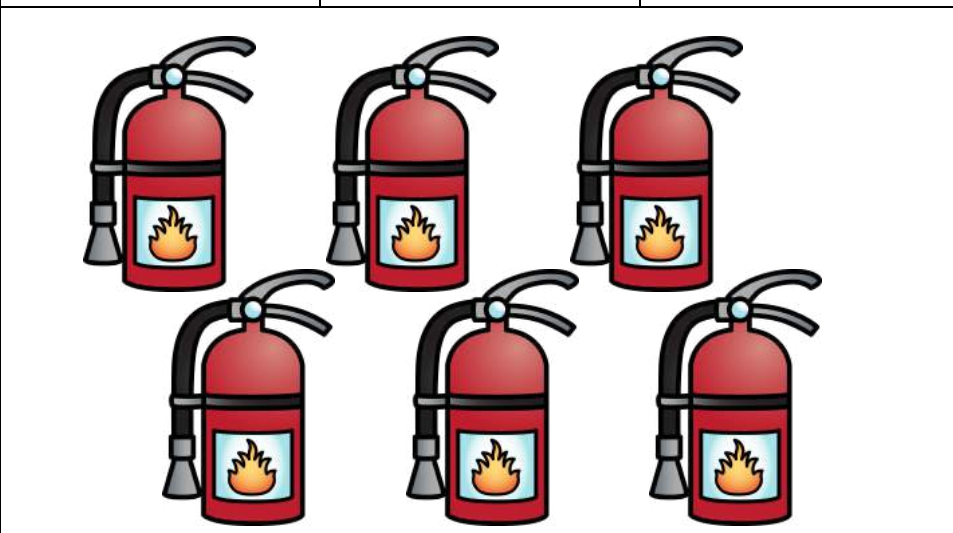

1

3

6

10

2

5

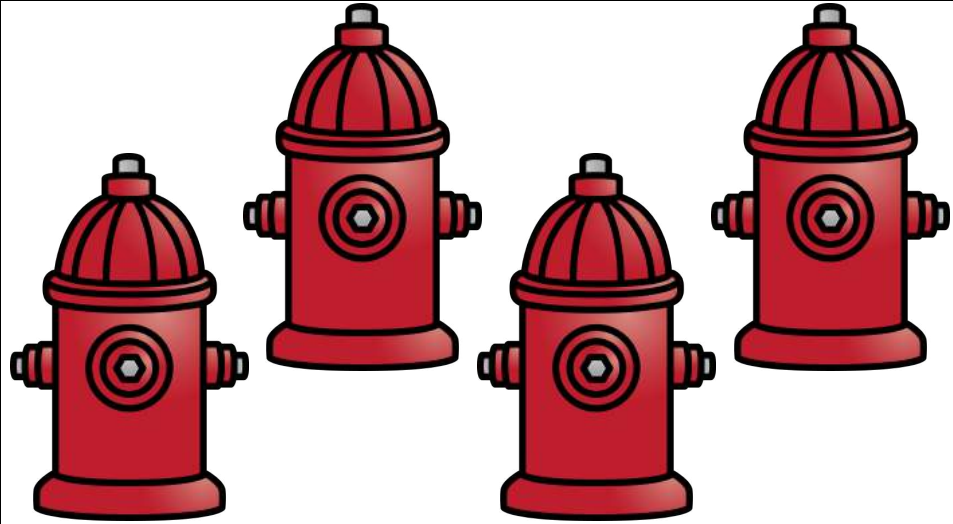

5

2

4



3

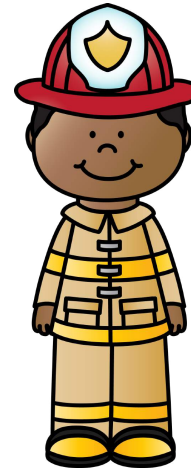

7



8

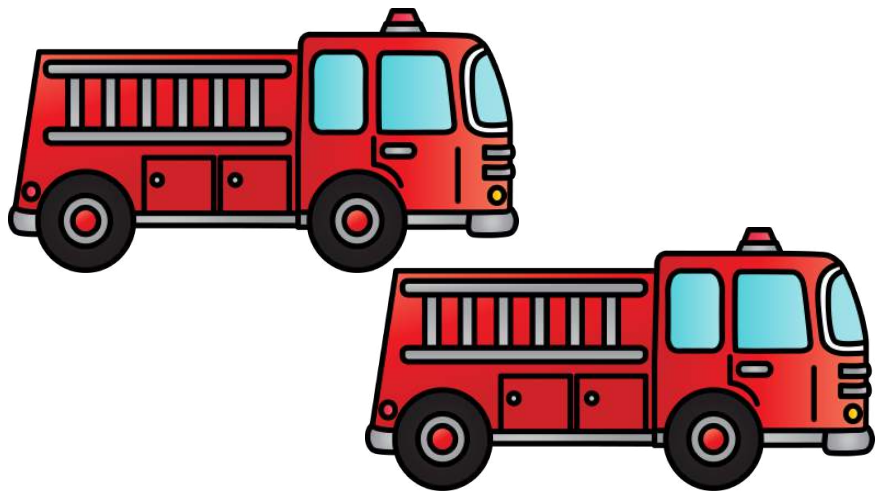

1

2

6



9

5

1

Concentration

Objective: The students will use visual discrimination (matching) skills to identify two identical objects.

Preparation: Print the picture cards. Mat onto cardstock and/or laminate as desired. Cut apart.

Procedure: Place cards facing down. Students take turns flipping over 2 cards at a time. If the cards match, the student gets to keep the pair. If they don't match, they return them to the face-down position and try again.

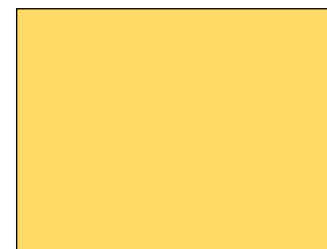
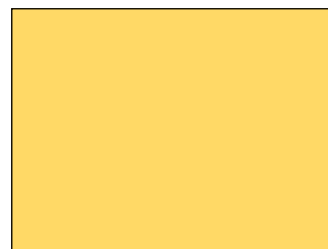
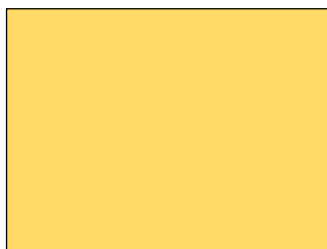
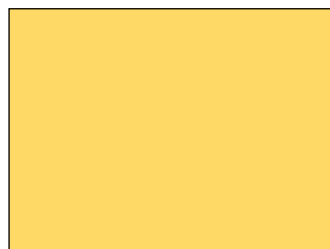
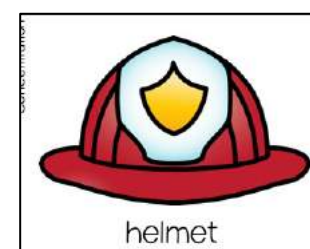
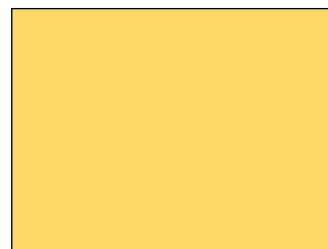
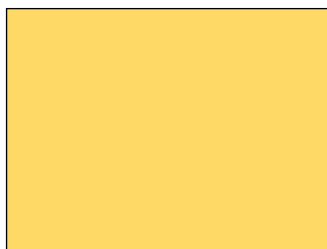
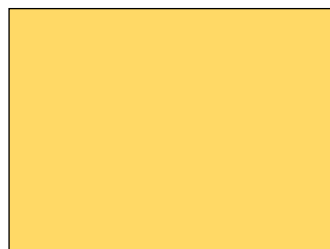
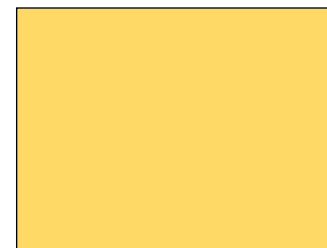
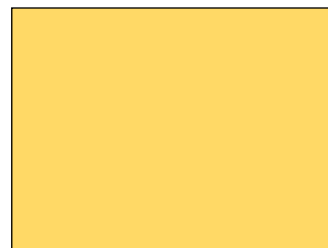
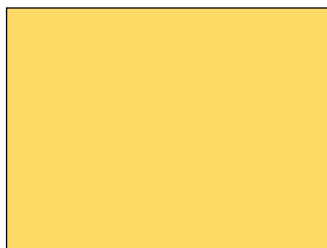
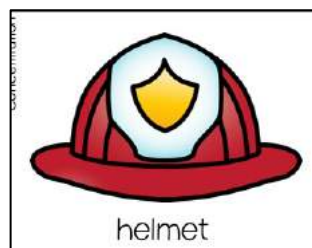

Concentration

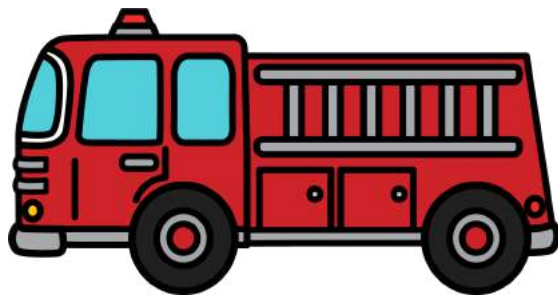

fire truck

Concentration

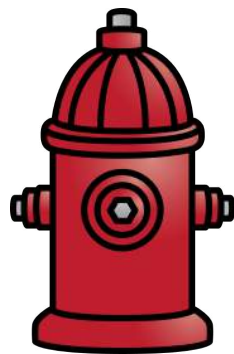

fire hydrant

Concentration



helmet

Concentration



stop sign

Concentration

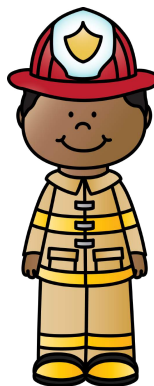

firefighter

Concentration



mask

Concentration



fire

Concentration

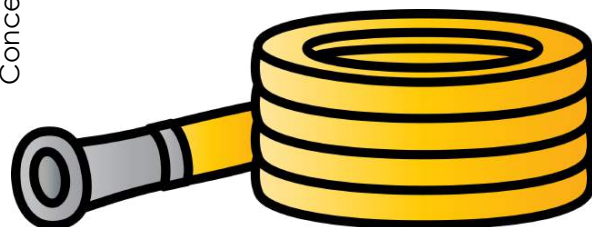

hose

Concentration



fire boots

Concentration

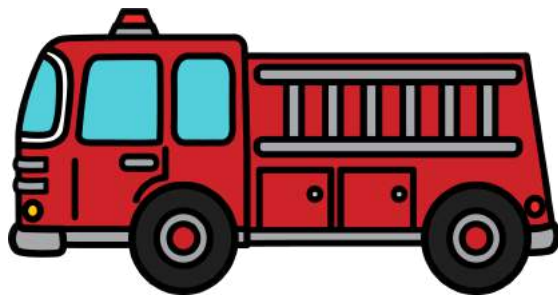

fire truck

Concentration



fire hydrant

Concentration



helmet

Concentration



stop sign

Concentration

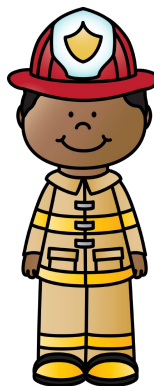

firefighter

Concentration



mask

Concentration



fire

Concentration

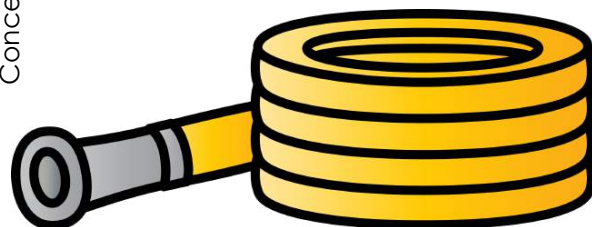

hose

Concentration



fire boots



Firefighter books

for Preschoolers



- *Firefighter Ted* by Andrea Beaty and Pascal Lemaitre
- *Spark the Firefighter* by Stephen Krensky
- *Miss Mingo and the Fire Drill* by Jammie Harper
- *Pete the Cat: Firefighter Pete* by James Dean
- *Spark the Firefighter* by Stephen Krensky
- *Poinsettia and the Firefighters* by Felicia Bond
- *Firebears, The Rescue Team* by Rhonda Gowler Greene
- *A Day in the Life of a Firefighter* by Linda Hayward
- *My Mom is a Firefighter* by Lois Grambling
- *Firefighter Frank* by Monica Wellington
- *Firefighters A-Z* by Chris L. Demarest
- *Flashing Fire Engines* by Tony Mitton
- *The Firefighter* by Jenny Goebel
- *Five Little Firefighters* by Thomas Graham
- *Fire Engine Many* by Andrea Zimmerman & David Clemesha
- *Fire Drill* by Janet Craig
- *The Little Firetruck* by Margery Cuyler

More resources

for preschool and Pre-K learners:

Connect:



- [Newsletter](#)
- [Facebook](#)
- [Instagram](#)
- [Blog](#)
- [Pinterest](#)

Resource Bundle

save
\$\$

Credit:

These talented artists made this possible.



kimberly
geswein
fonts



Terms of Use:

Play to Learn resources are for personal classroom and home use only. They may not be used commercially.

YES:

- You may use this resource at home with your own children or in your classroom with your own students.
- You may print copies for your own children or students.
- You may send printed copies home with your students.
- You may use these lessons yourself to provide virtual teaching videos for your own students who might be learning at home.

NO:

- You may NOT post this file to any file sharing website. (DropBox, Google Drive, Facebook, Amazon, SeeSaw, etc.)
- You may NOT resell these resources.
- You may NOT send these PDFs via email for students to print at home.
- You may NOT share these PDFs with colleagues via email or otherwise.
- You may not claim these resources or ideas as your own.
- You may NOT use these resources to teach lessons that you **sell** online. (Teaching your own students – great. Selling these lessons, even if you do them yourself, online – not permitted.) This includes OutSchool and similar platforms.

Alphabet Activities

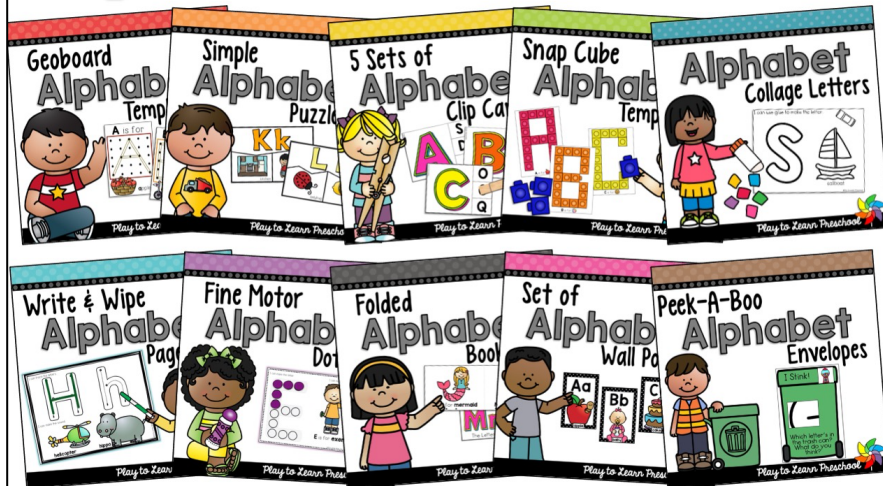

for Preschoolers

Play to Learn Preschool



These alphabet activities will help your young learner learn the letters of the alphabet!